

# NOEtop

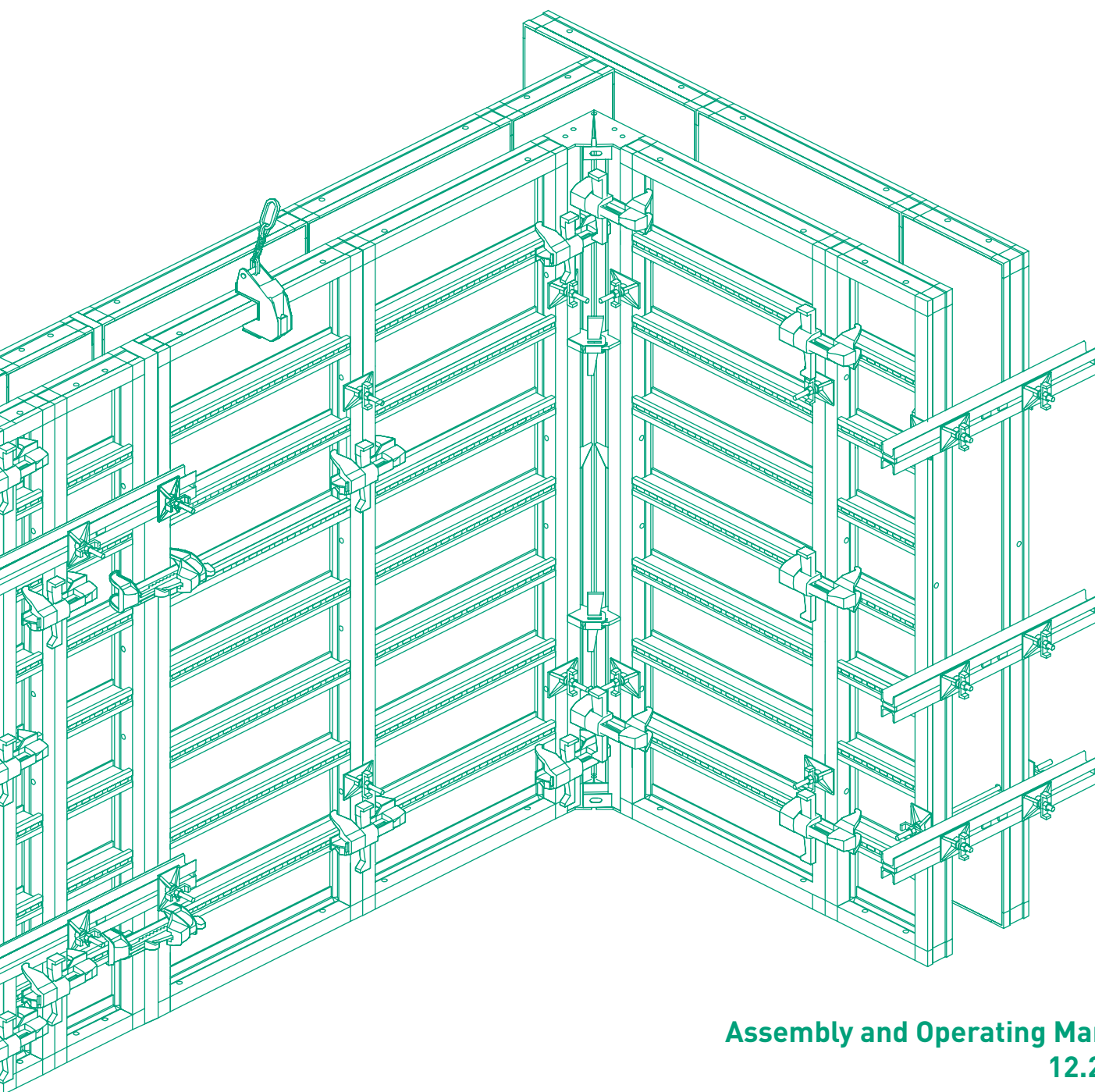



Contents

	Page		Page
1	4	12.2.4	50
1.1	4	12.2.5	51
1.2	5	12.2.6	52
2	6	12.2.7	54
3	8	12.3	55
3.1	8	13	56
3.2	8	13.1	56
3.2.1	8	13.1.1	57
3.2.2	11	13.1.2	58
3.2.3	14	13.1.3	60
3.3	15	13.1.4	62
3.4	15	13.2	63
3.4.1	15	13.3	64
3.4.2	17	13.4	65
3.5	17	14	66
4	18	14.1	66
4.1	18	14.2	67
4.2	19	14.3	68
5	20	14.3.1	68
5.1	20	15	69
5.2	20	15.1	69
5.3	20	15.1.1	69
5.4	20	15.1.2	69
5.5	21	15.1.3	70
5.6	22	15.1.4	70
5.7	22	15.1.5	71
5.7.1	23	15.1.6	71
6	25	15.1.7	72
6.1	25	15.1.8	72
6.2	25	15.1.9	72
6.3	25	15.2	73
6.4	26	15.2.1	73
6.5	26	15.3	75
6.6	26	15.3.1	75
7	27	15.3.2	75
7.1	27	15.3.3	77
7.1.1	27	15.3.4	78
7.1.2	28	15.4	79
7.1.3	29	15.5	80
7.2	29	15.5.1	80
7.2.1	30	15.5.2	81
7.2.2	31	15.6	82
8	32	15.7	85
9	33	16	86
10	34	16.1	86
10.1	34	16.1.1	86
10.2	34	16.1.2	87
10.3	35	16.1.3	88
10.4	36	16.2	89
10.5	37	16.2.1	89
10.6	37	16.2.2	90
11	38	16.3	91
11.1	38	16.4	92
11.2	39	16.5	93
11.2.1	39	16.6	93
11.2.2	39	16.6.1	93
11.2.3	40	16.6.2	93
11.2.4	41	16.7	94
11.3	42	16.8	95
11.3.1	42	16.9	96
11.3.2	42	16.10	96
11.3.3	42	16.11	97
11.3.4	43	16.12	97
11.3.5	43	16.13	98
11.4	44	16.14	98
12	45	16.15	99
12.1	45	16.16	100
12.2	46	16.17	101
12.2.1	47	16.18	102
12.2.2	48	16.19	103
12.2.3	48	16.20	103
		16.21	110
		16.22	111
		Appendix I: External corner panels b = 750 mm	112
		Appendix II: Panel height 3000 mm (symmetrical panel arrangement)	114

## 1. Safety advice, GSV guidelines

### 1.1 Advice on proper and safe use of formwork and falsework

The contractor is responsible for drawing up a comprehensive risk assessment and a set of installation instructions. The latter is not usually identical to the assembly and use instructions.

- **Risk assessment:** The contractor is responsible for the compilation, documentation, implementation and revision of a risk assessment for each construction site. His employees are obliged to implement the measures resulting from this in accordance with all legal requirements.
- **Installation instructions:** The contractor is responsible for compiling a written set of installation instructions. The assembly instructions form part of the basis for the compilation of a set of installation instructions.
- **Assembly and use instructions:** Formwork is technical work equipment and is intended for commercial use only. It must be used properly and exclusively through trained specialist personnel and appropriately qualified supervising personnel. The assembly and use instructions are an integral component of the formwork construction. They comprise at least safety guidelines, details on the standard configuration and proper use, as well as the system description. The functional instructions (standard configuration) contained in the assembly instructions are to be complied with exactly as stated. Enhancements, deviations or changes represent a potential risk and therefore require separate verification (with the help of a risk assessment) or a set of installation instructions that comply with the relevant laws, standards and safety regulations. The same applies in those cases where formwork and/or falsework components are provided by others on site.
- **Availability of the assembly and use instructions:** The contractor must ensure that the assembly and use instructions provided by the manufacturer or formwork supplier are available at the place of use, that site personnel are informed of this before assembly and use takes place, and that they are available at all times.
- **Representations:** The representations (drawings, diagrams etc.) shown in the assembly instructions are, in part, situations of assembly and not always complete in terms of safety considerations. Any safety installations that may not have been shown in these representations must nevertheless be available.
- **Storage and transportation:** Any special requirements relating to transportation procedures and storage of the formwork constructions must be complied with. An example would be the use of the appropriate lifting gear.
- **Material check:** Formwork and falsework material deliveries are to be checked on arrival at the construction site/place of destination as well as before each use to ensure that they are in perfect condition and function correctly. Changes to the formwork materials are not permitted.
- **Spare parts and repairs:** Only original components may be used as spare parts. Repairs are to be carried out by the manufacturer or at authorised repair facilities only.
- **Use of other products:** Combining formwork components from different manufacturers carries certain risks. They are to be individually verified and can result in the compilation of a separate set of assembly instructions required for the installation of the equipment.
- **Use of other products:** Individual safety symbols are to be complied with. Examples:



**Safety information:** Non-compliance can lead to damage to materials or risk to the health of site personnel (also life).



**Visual check:** The intended operation is to be subject to a visual check.



**Note:** Supplementary information for safe, correct and professional execution of work activities.

- **Miscellaneous:** We reserve the right to make amendments in the course of technical development. All current country-specific laws, standards and other safety regulations are to be complied with without exception for the safe application and use of the products. They form a part of the obligations of employers and employees regarding industrial safety. This gives rise to, among other things, the responsibility of the contractor to ensure the stability of the formwork and falsework constructions as well as the structure during all stages of construction, which also includes the basic assembly, dismantling and the transport of the formwork and falsework constructions or their components. The complete construction is to be checked during and after assembly.

1.2 Safe setting down of wall formwork elements

Double-faced formwork system

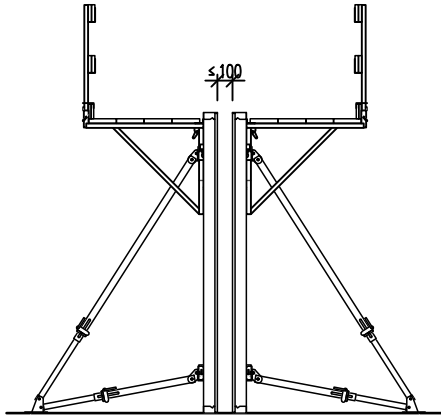

Single-faced formwork system

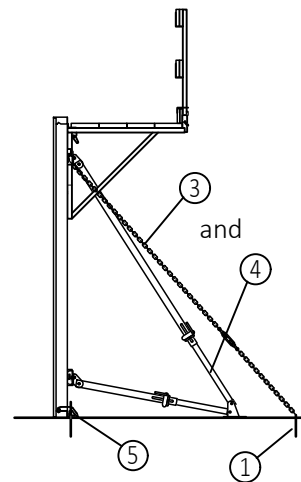
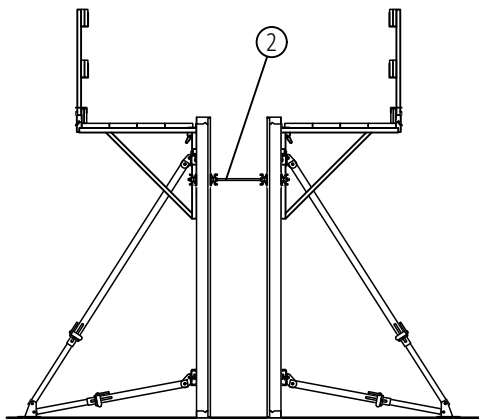
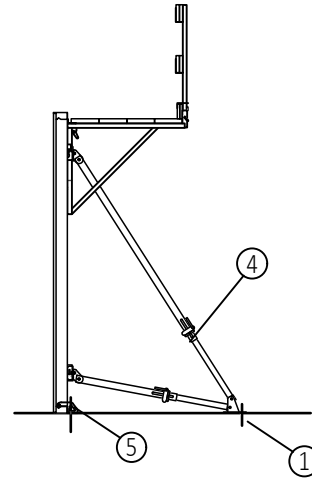



To avoid accidents always set elements down in such a way that they are structurally stable (guy, brace, anchor) this includes placing them down safely on the ground.

If the stabilizers are anchored with an anchor bolt, they must be able to act in compression and tension. At least 2 stabilizers must be attached to single panels. Attach the uplift safety device in the event of wind loads.

For the length and fastening of the stabilizers see 15.6 and 15.7.

- 1 Anchor bolt
- 2 Tie rod  
(to resist tension and compression)
- 3 Guy
- 4 Stabilizer
- 5 Uplift safety device

## 2. Overview of the NOEtop panel formwork system

Tie rod  $\varnothing 15$  mm - permissible concrete pressure 60 kN/m<sup>2</sup> in acc. with DIN 18218 !

Tie rod  $\varnothing 20$  mm - permissible concrete pressure 88 kN/m<sup>2</sup> in acc. with DIN 18218 !

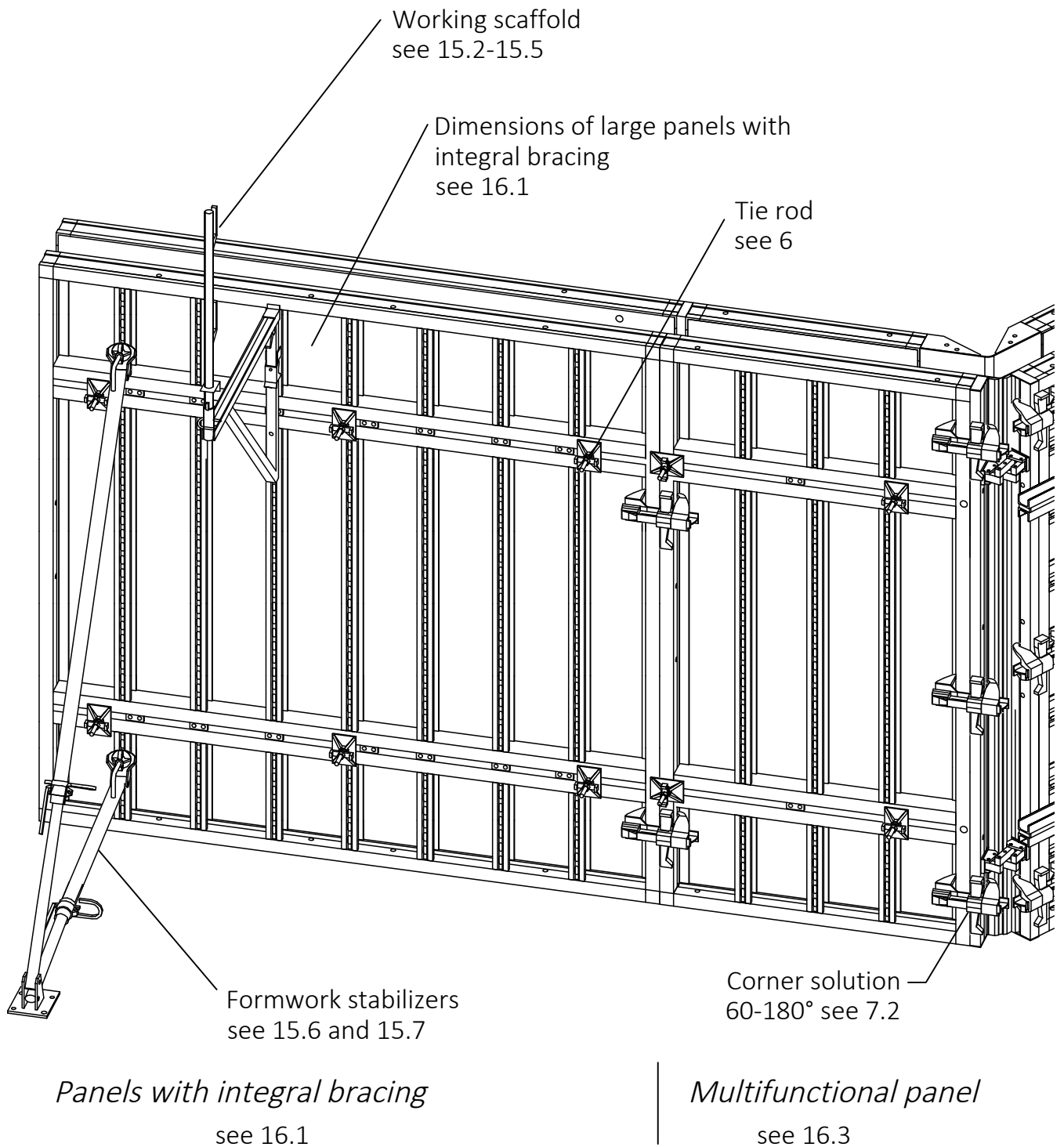

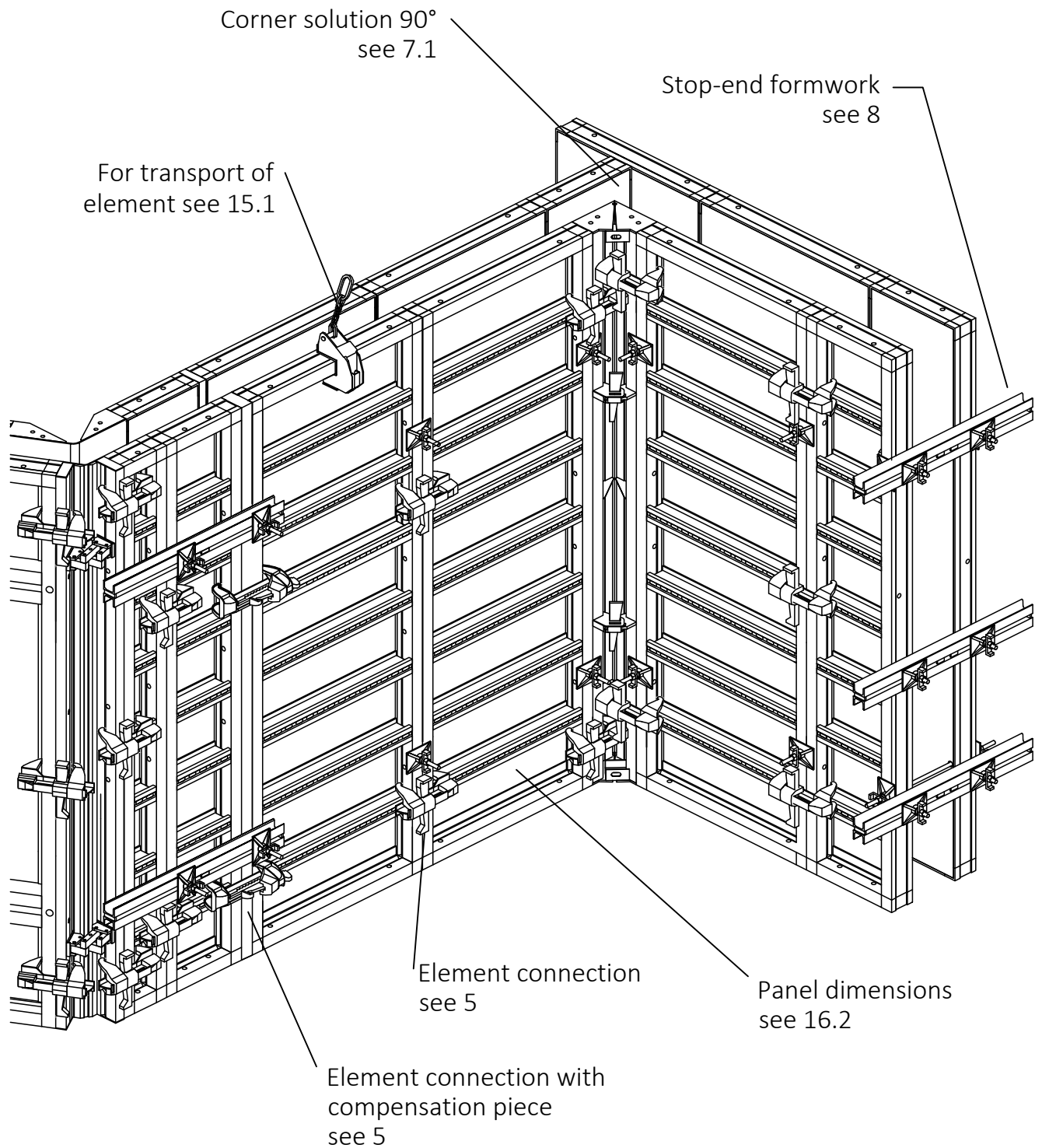

*Standard panels*  
see 16.2

### 3. Assembly instructions

The individual steps for assembly and erection are shown diagrammatically in the following pages. When erecting formwork, we recommend that you start at a corner; when stripping formwork, it is best to start from the stopend form or from the compensation piece to the corner, as appropriate.

→ Indicates to relevant chapters, where the steps are shown in detail.



Before using the formwork, read through the assembly and operating manual and observe the safety advice given in each chapter at all times!  
Everyone who works with the product must receive instruction from a suitably qualified member of the site supervisory staff.



A risk analysis covering all situations on site must be carried out by a responsible person.  
Components must be free of defects. Therefore visual inspection and/or testing of each component are essential at all stages of the work!

#### 3.1 Unloading formwork elements

⇒ Refer to 15.1 for transporting formwork

#### 3.2 Erecting formwork

##### 3.2.1 Preassembling the first face formwork

- ◆ To assemble the elements into one unit, lay the panels down on a suitable level surface and connect them using formwork locks. Support the face on e.g. lengths of squared timber to avoid causing damage to the formwork lining.

⇒ Refer to Chapter 5 for connection elements

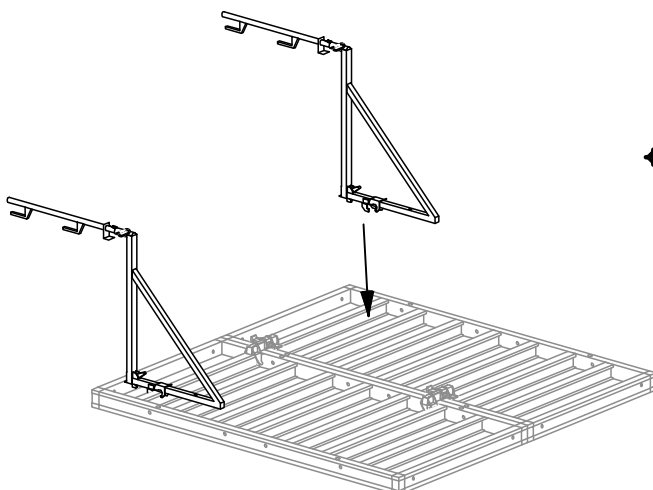
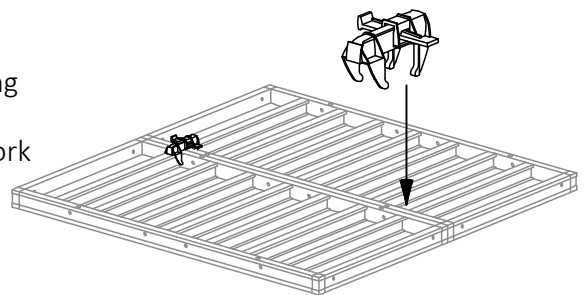

- ◆ Attach walkway brackets



Check that they are properly seated and securely fastened in place!

⇒ Refer to 15.2 and 15.5 for walkway brackets

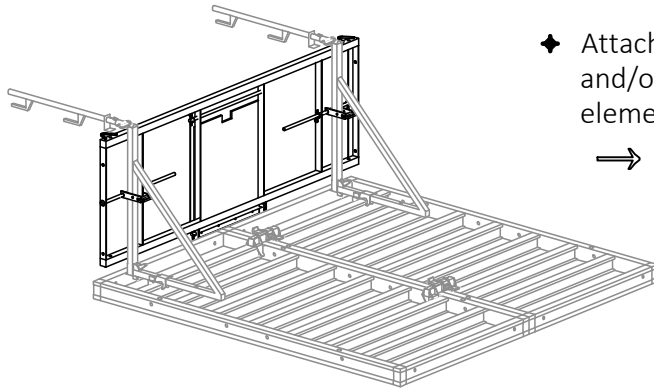

First element with platform and trapdoor

- ◆ Attach NOEtop working platform (1st element) and/or scaffold planks (and all additional elements).

⇒ Refer to 15.2 and 15.5 for scaffolding

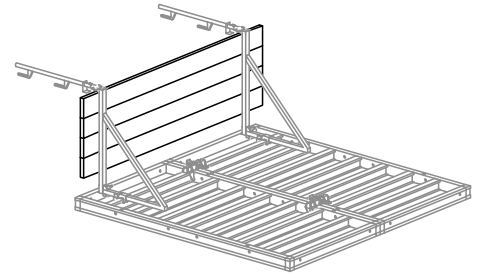

Additional elements with boarding

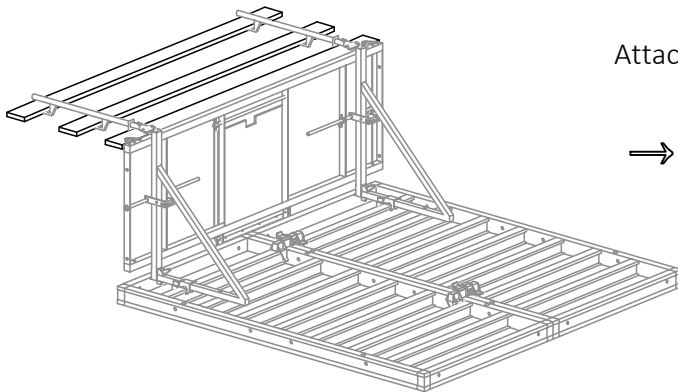

Attach guardrail boards and toeboard.

⇒ Refer to 15.2 and 15.5 for scaffolding

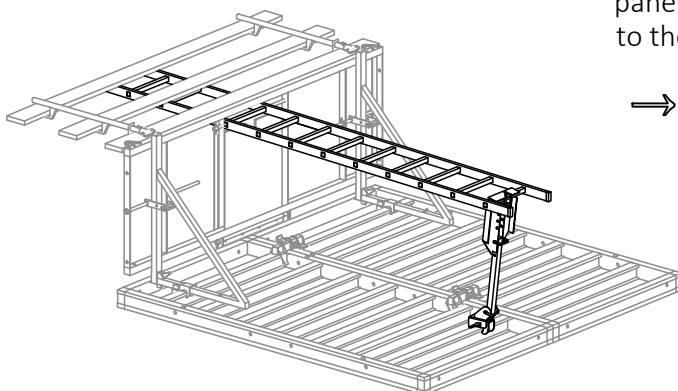

- ◆ On 1st element: Attach ladder support to the panel and fasten the ladder to the support and to the working platform.

⇒ Refer to 15.5 for scaffolding



- ◆ Attach stabilizers (2 No. on the first combined element, 1 No. on each further element).

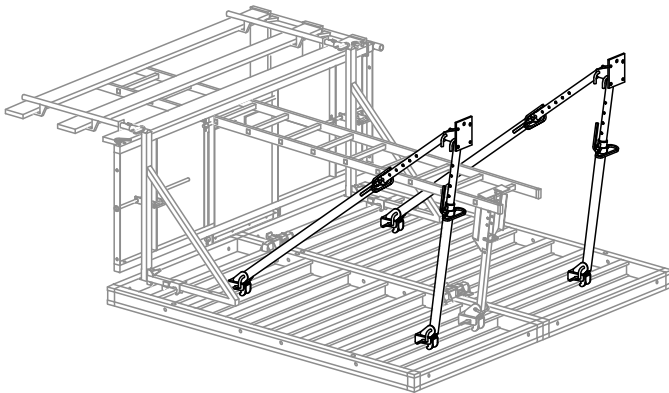

First element with 2 stabilizers

→ Refer to 15.6 and 15.7 for stabilizers

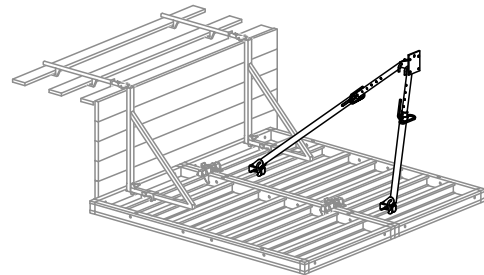

Each further element has one stabilizer

- ◆ Attach guard-rail clamps and guardrail boards to the first and last elements of a length of the object to be cast (if required also at corners, stepped projections etc.) to prevent falls from the open platform ends.

End protection with scaffold platform adapter handrail tube Part No. 550025 and handrail tubes.  
Alternatively: End protection with NOEtop front guard-rail (see 15.5.2)

End protection with guard-rail clamps

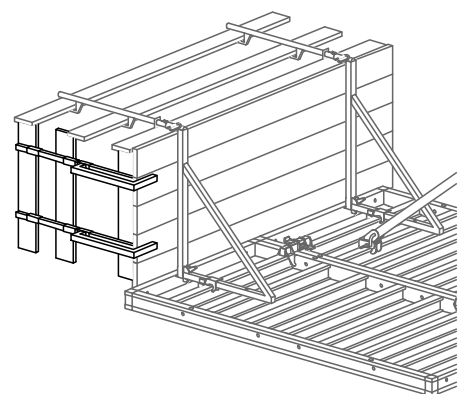
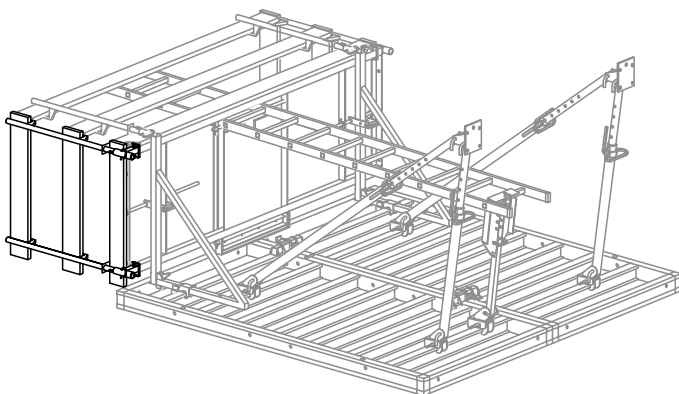

- ◆ Erect element as described in 3.2.2 and preassemble the other elements for the length of the object to be cast, as described above.

## 3.2.2 Erecting the first face formwork

	For safe transport: Do not exceed the maximum permissible load on the crane bow!		max. 20 kN vertical → Observe limits in table in 15.1.4 → Operating instructions
--	----------------------------------------------------------------------------------------	--	----------------------------------------------------------------------------------------

- ◆ Sling crane bow with hanger and lift the combined unit slowly with the crane (if the lift is too rapid the stabilizer may strike the ground!).  
⇒ Refer to 15.1 for transporting formwork

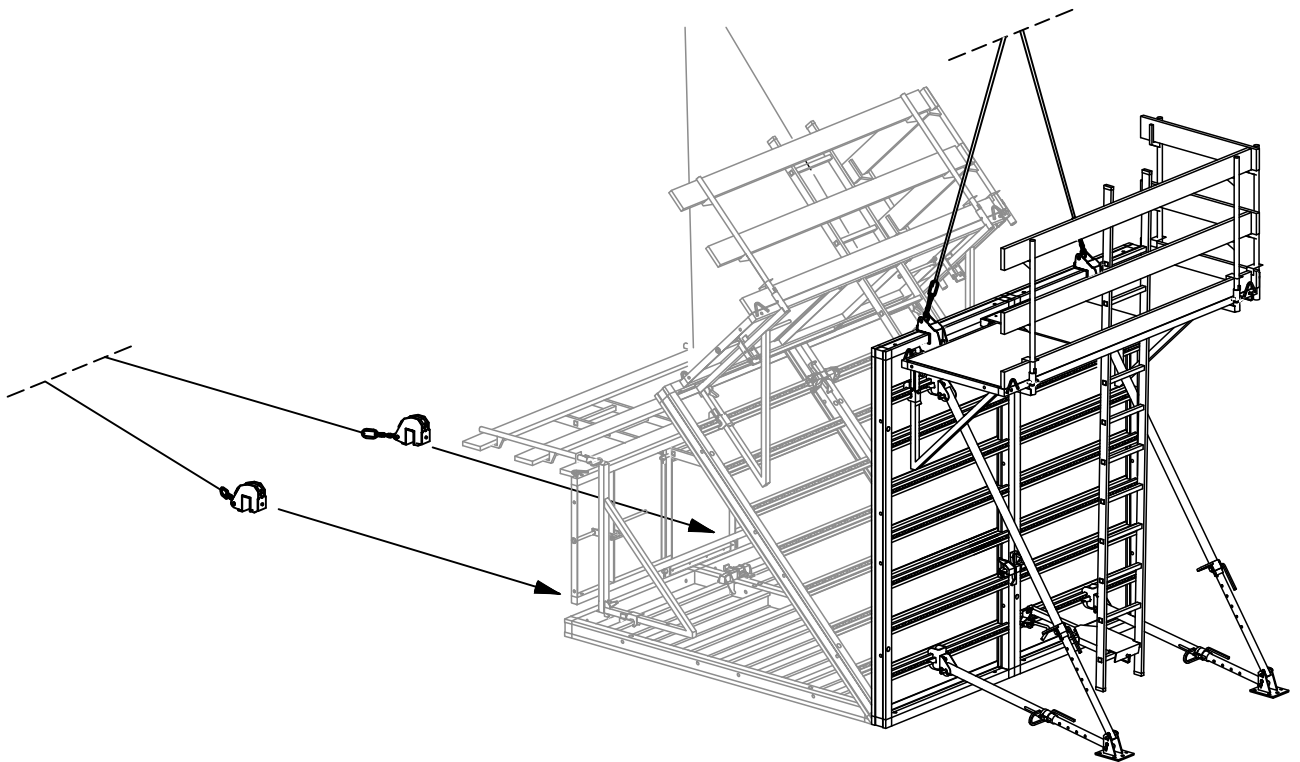

# NOEtop formwork



- ◆ Once the combined element has been placed and correctly aligned in its installation position, anchor the element stabilizers to the base using a force-transmitting anchor.

⇒ Refer to 15.6 and 15.7 for stabilizers

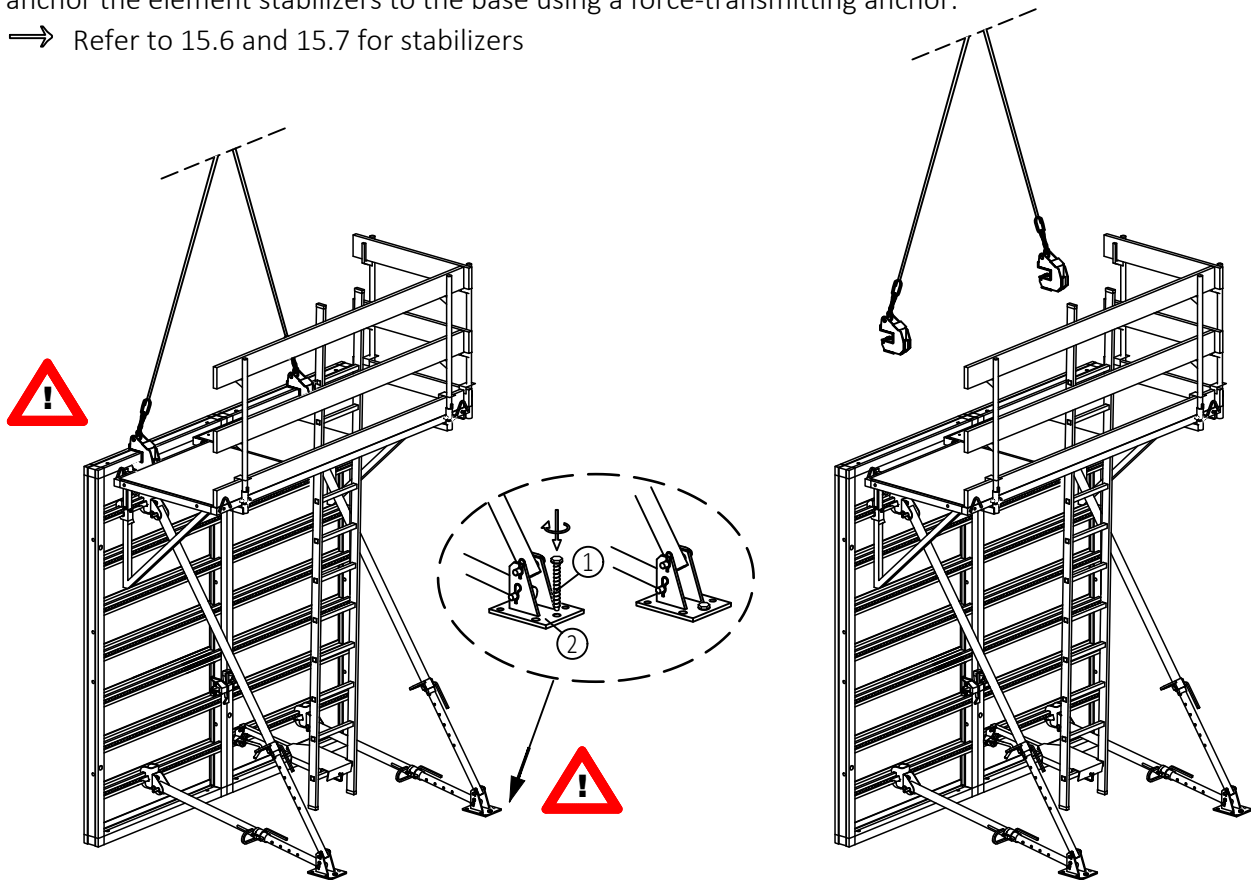

- 1 Bolt MMS plus 16x130  
Part No. 313151
- 2 Bottom support

- ◆ Once the stabilizers have been fastened in accordance with the instructions, climb up the ladder on to the platform and disconnect the crane bow whilst standing on the platform.

⇒ Refer to 15.1.4 for crane bow



Anchor the stabilizers against tension and compression forces to ensure structural stability before releasing the crane bow.

**ATTENTION: Danger of falling inside the formwork!**  
(For heights > 2 m take precautions to ensure safety against falling!)

⇒ Refer to 15.4

- ◆ Preassemble the other elements in accordance with 3.2.1 and lift them into place in the installation position with the crane.

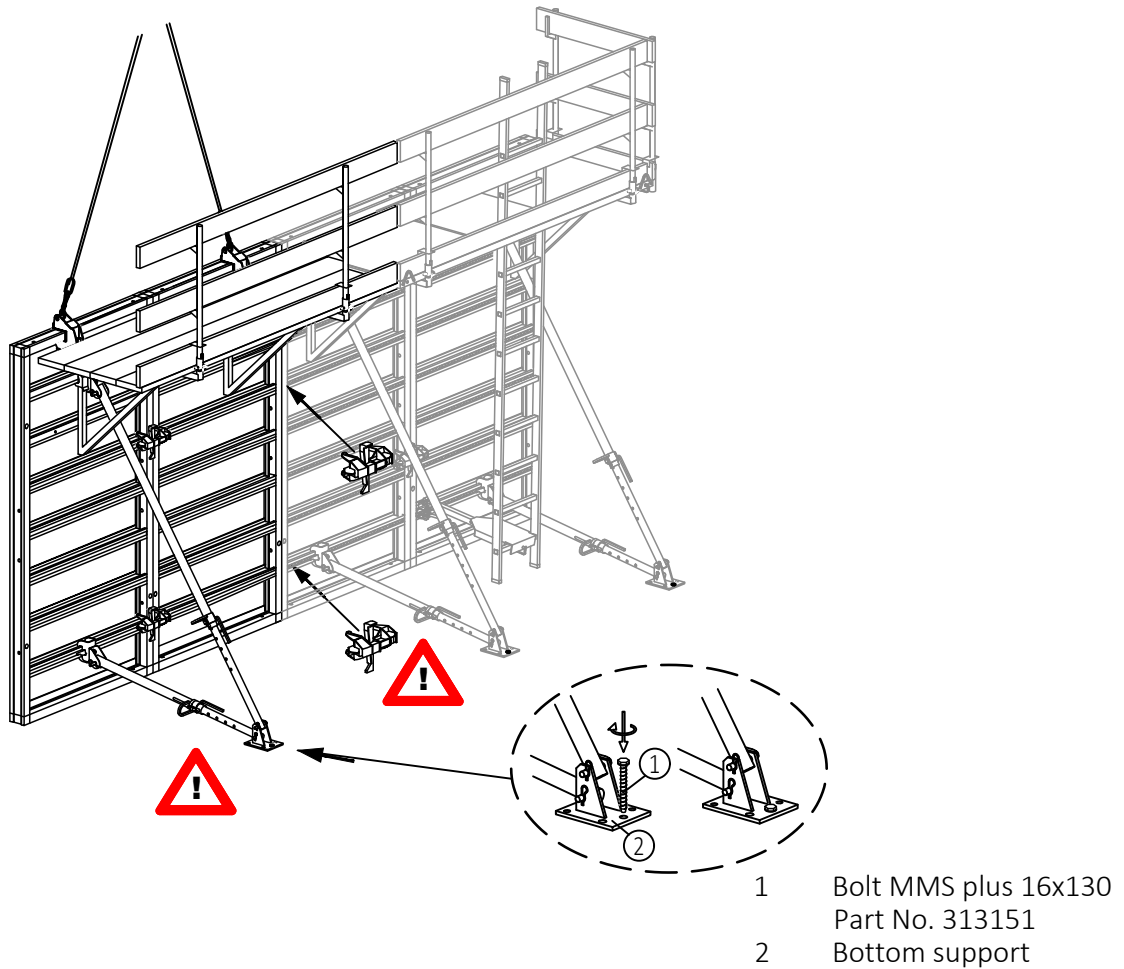

- ◆ Attach the first connections and anchor the stabilizer using a force transmitting anchor, then detach the crane bow whilst standing on the platform.  
To reach this point use the ladder to climb up to the working platform of the first element, climb through the trapdoor and walk along the platform from there.



Anchor the stabilizers against tension and compression forces and attach connections to ensure structural stability before releasing the crane bow.

ATTENTION: Danger of falling inside the formwork!  
(Ensure safety against falling from heights > 2 m by providing suitable measures!)

⇒ see 15.4

ATTENTION: Danger of falling from the open scaffold side, take appropriate care!

# NOEtop formwork



### 3.2.3 Installing the (opposing) second face formwork

- ◆ Preparing the first face formwork: Apply release agent to the front and rear formwork faces in accordance with the formwork preparation instructions, fix reinforcement in position, install tie rods and sleeves, seal any surplus tie rod holes with plugs.



If no fall protection measures were attached to the first face formwork for formwork heights > 2.00 m then the appropriate safety measures must now be installed (if necessary preattach the fall safety measures while the second face formwork is on the ground).

→ Refer to 15.4 for fall protection

- ◆ Attach the crane bow to the second face formwork, lift it with the crane, apply release agent to the front and rear face in accordance with the formwork preparation instructions and place it in the installation position

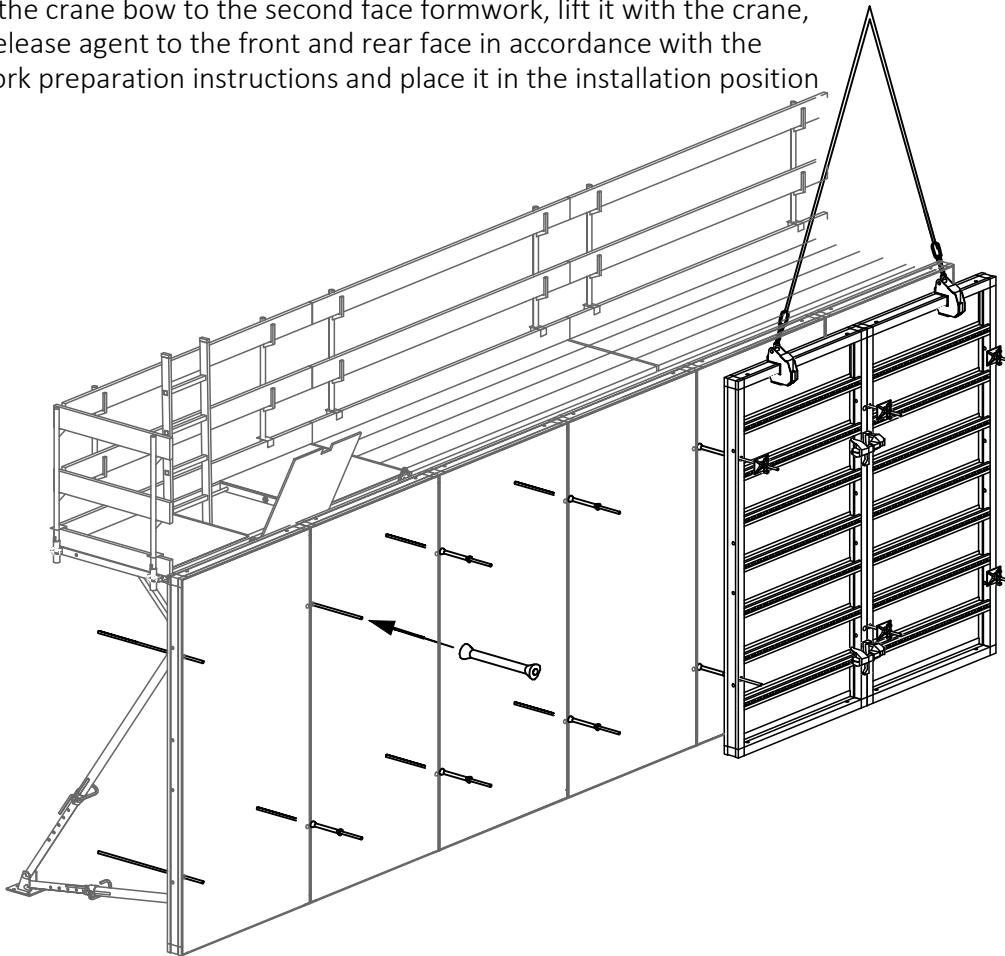



Do not release the crane bow until after the tie rods are installed for the first element and, in the case of further elements, a top tie rod is installed and tensioned and the connections are installed.

- ◆ Once the element is secured, climb the ladder to the platform on the first face formwork and detach the crane bow from there. Pay particular attention to the danger of falling! Alternatively the crane bow can be detached from at ground level.

→ Refer to 15.4 for fall protection and 15.1 for crane transport

- ◆ Repeat this procedure for the full length of the object to be cast.

## 3.3 Concreting

 Before concreting starts check the anchors, ties and connections for

- Completeness
- Correct positioning
- Effective locking

- ◆ Do not exceed the permissible pressure during concreting (DIN 18218 "Pressure of fresh concrete on vertical formwork"), i.e. pay attention to the rate of rise of the concrete.

- For tie rods  $\varnothing 15$  mm    permissible concrete pressure 60 KN/m<sup>2</sup>  
- For tie rods  $\varnothing 20$  mm    permissible concrete pressure 88 KN/m<sup>2</sup>

- ◆ If using internal vibrators refer to DIN 4235 Part 2 "Compaction of concrete by internal vibrators".

## 3.4 Stripping formwork

### 3.4.1 Stripping the second face formwork - formwork without scaffolding

 Before stripping first check:

- Minimum stripping times!
- Concrete compressive strength!

When stripping start with the panels without stabilizers!

- ◆ Attach the crane bow with a hanger to secure the element or combined element. Access for this operation is from the opposite platform.

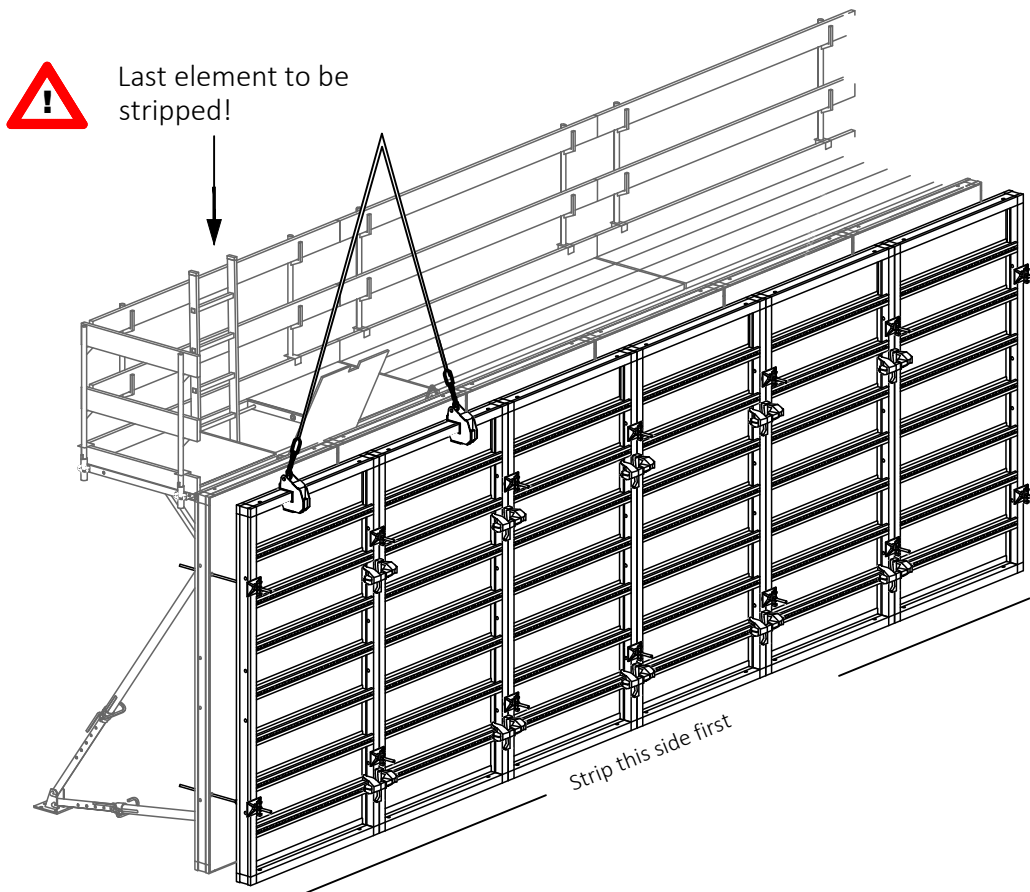

## NOEtop formwork

- ◆ Remove the tie rods from the elements or element combinations to be stripped, remove the connectors to the adjacent element and release the element from the concrete. Use pry bars or similar tools; never pull panels free with a crane.

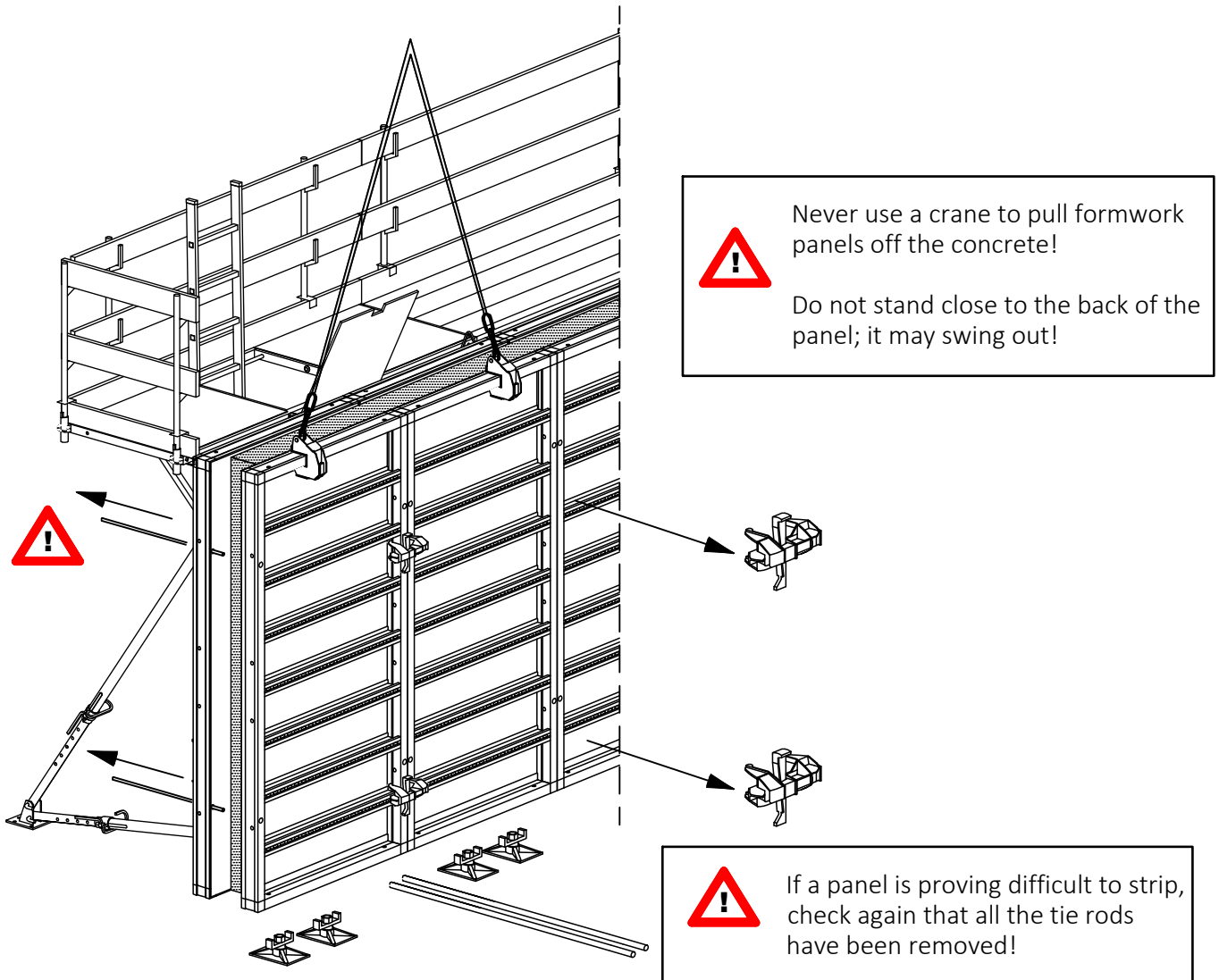

- ◆ Place the element down in a stable position (see 1.2) and detach the crane bow (see 15.1.6).
- ◆ Clean the formwork elements before each further use and apply release agent.

### 3.4.2 Stripping the first face formwork - formwork with scaffolding

- ◆ Remove any loose parts from the platform and, whilst working from the platform, attach the crane bow and hanger to the combined element.

 To ensure safe access:  
Strip the combined element with trapdoors in their platforms last

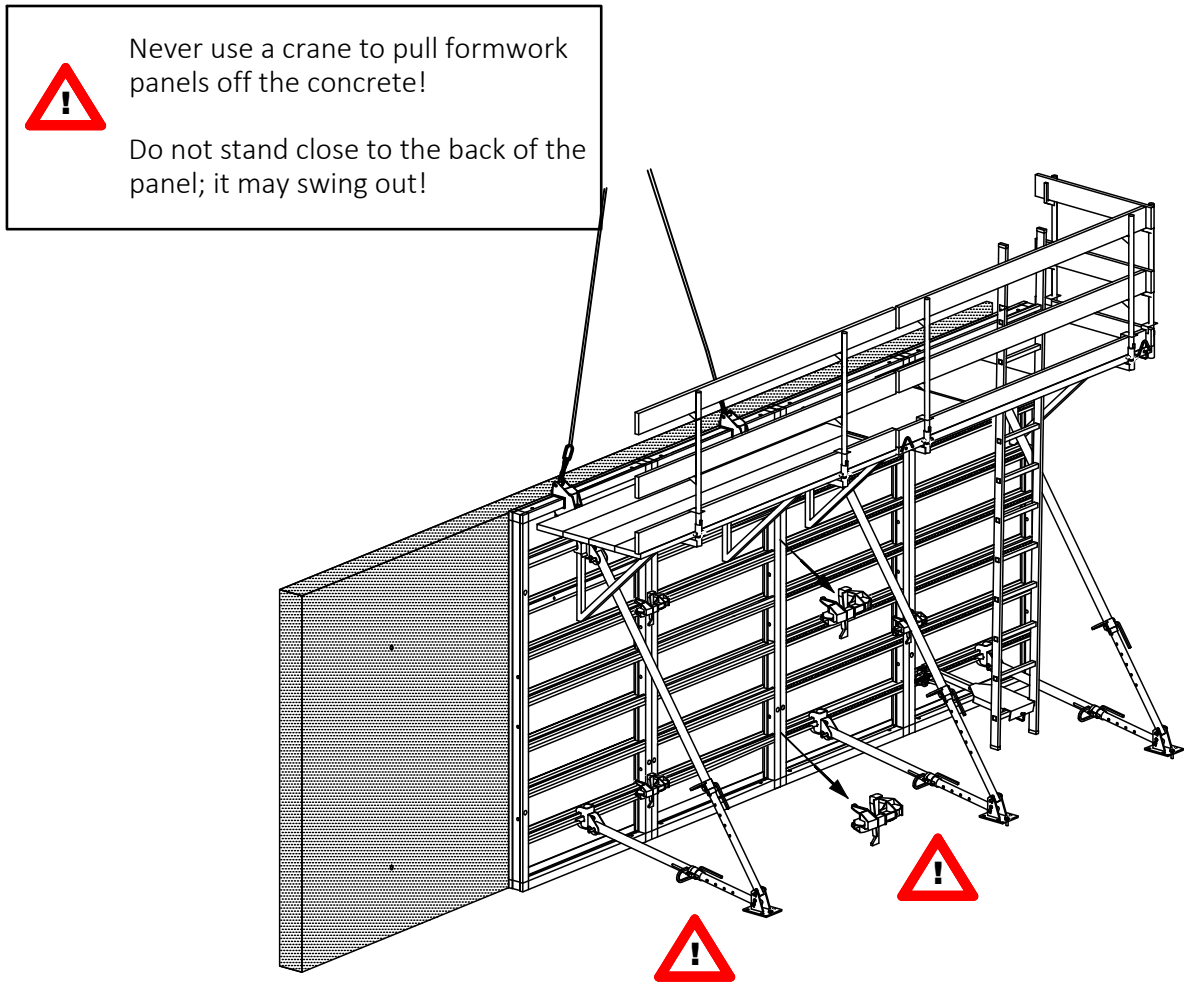

- ◆ Loosen the anchors to the stabilizers, remove the connectors to the adjacent combined unit and free the element from the concrete. Use pry bars or similar tools; never pull panels free with a crane.
- ◆ Place the element down in a stable position (see 1.2) and detach the crane bow (see 15.1.6).

### 3.5 Preparation for transport

- ◆ Dismantle stabilizers, scaffolds and elements. Refer to Section 3.2 using reverse order.
- ◆ Stack the cleaned elements and bind them into suitable groups for safe transport. Place small parts in NOE boxes for transport.  
⇒ Refer to 15.1 for transporting formwork



4. Standard construction  
4.1 Formwork height 2650 mm

For tie rods  $\varnothing 15$  mm permissible concrete pressure 60 KN/m<sup>2</sup> in acc. with DIN 18218!  
 Permissible tie rod load is 91 kN.  
 For tie rods  $\varnothing 20$  mm permissible. concrete pressure 88 KN/m<sup>2</sup> in acc. with DIN 18218!

◆ Elevation

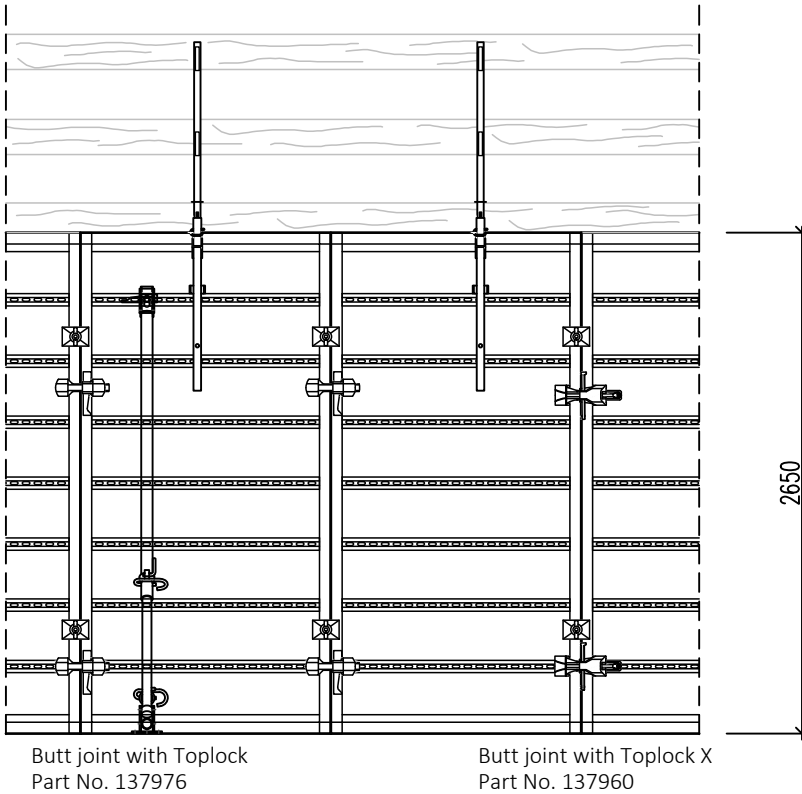

◆ Section

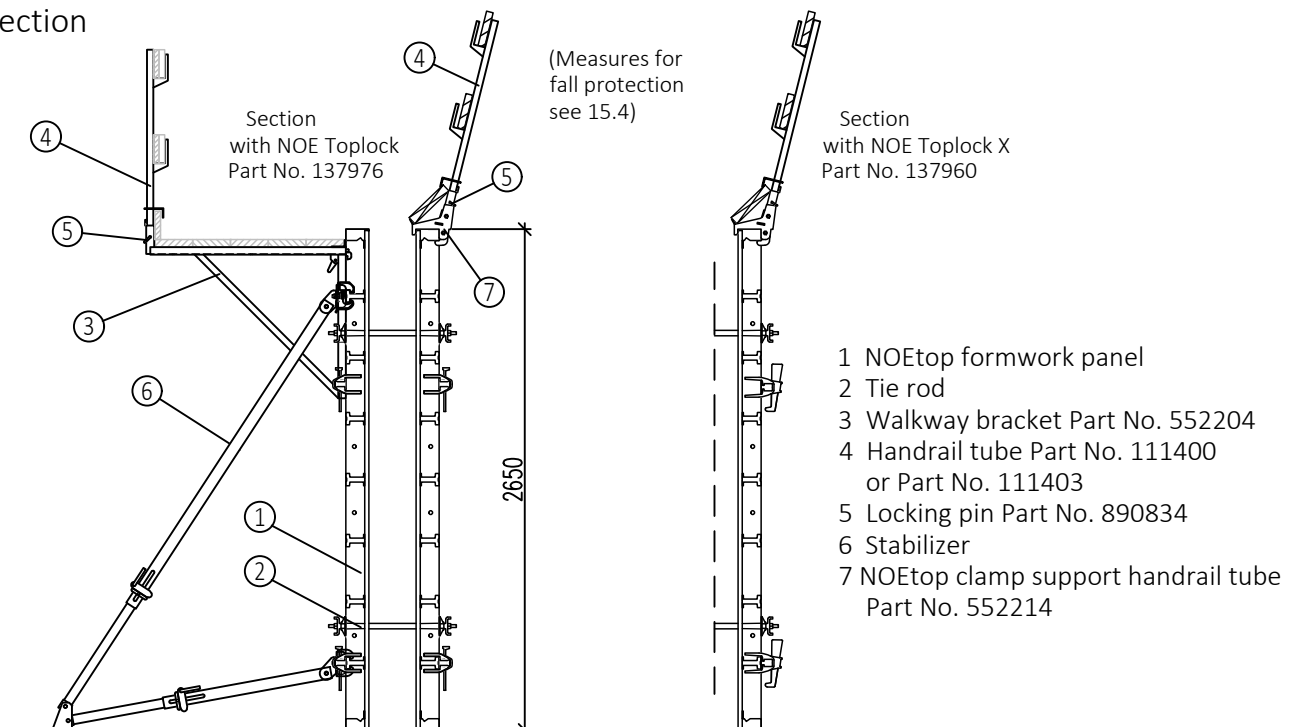

- 1 NOEtop formwork panel
- 2 Tie rod
- 3 Walkway bracket Part No. 552204
- 4 Handrail tube Part No. 111400 or Part No. 111403
- 5 Locking pin Part No. 890834
- 6 Stabilizer
- 7 NOEtop clamp support handrail tube Part No. 552214

4.2 Formwork height 3310 mm

Permissible concrete pressure - see Item 4.1

◆ Elevation

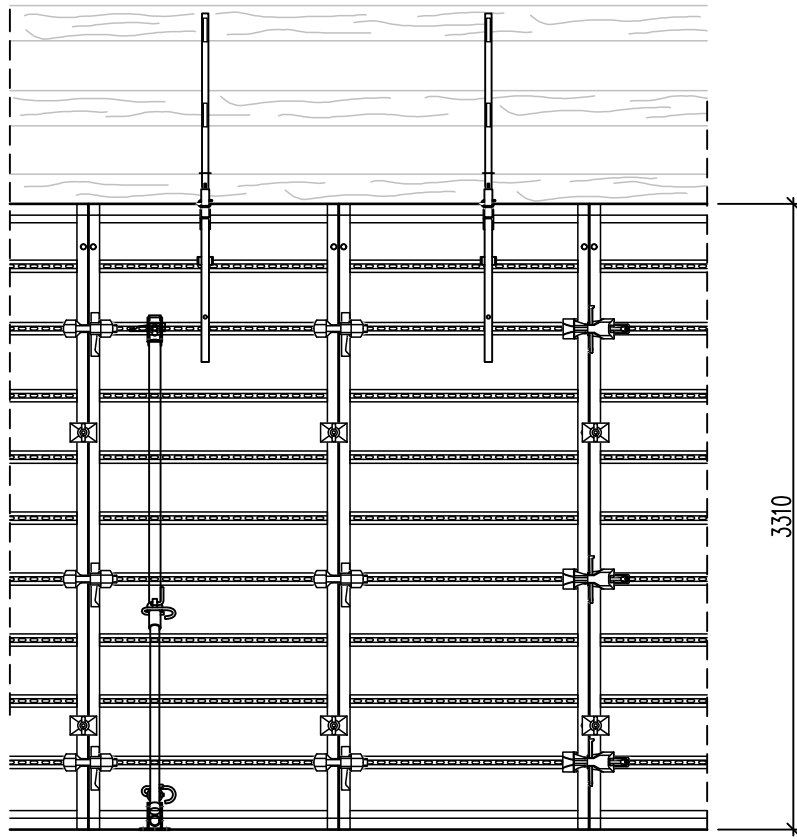

Butt joint with Toplock  
Part No. 137976

Butt joint with Toplock X  
Part No. 137960

◆ Section

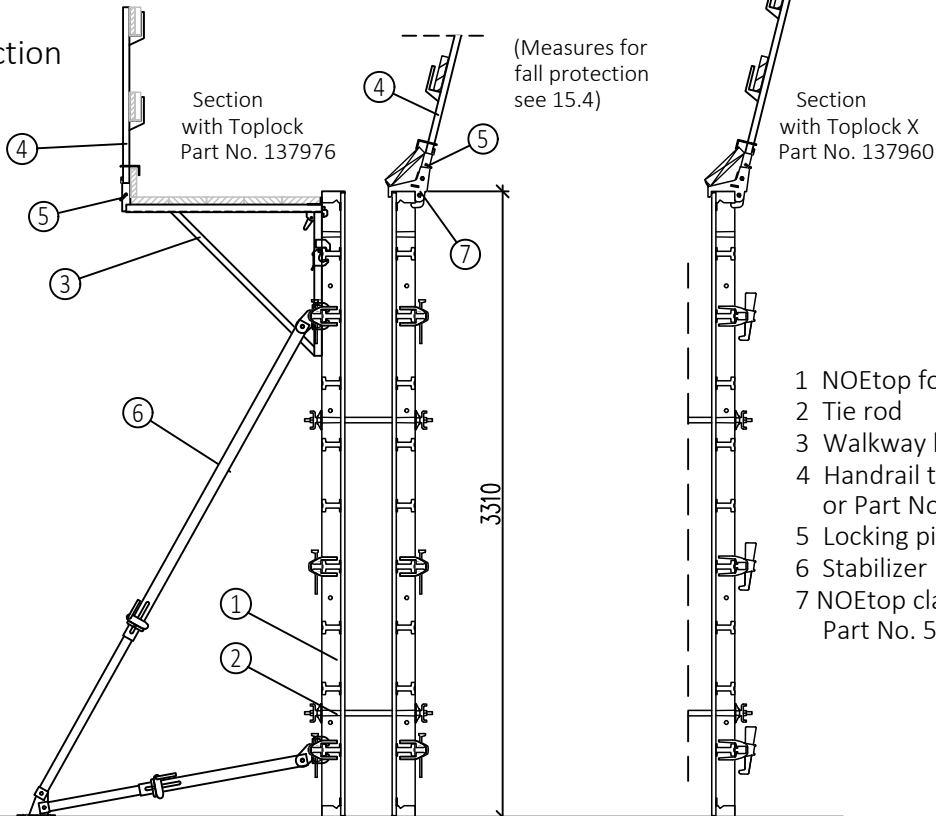

### 5. Element connections

(Ties not shown - see Chapter 6)

#### 5.1 Connection with NOE Toplock - with up to 42 mm compensation piece

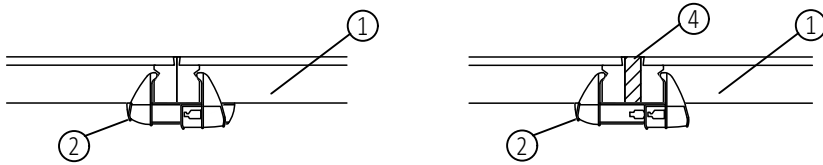

The NOE Toplock can be used on panel butt joints with a 0-42 mm compensation piece.

#### 5.2 Connection with NOE Toplock X - with a compensation piece of up to 100 mm

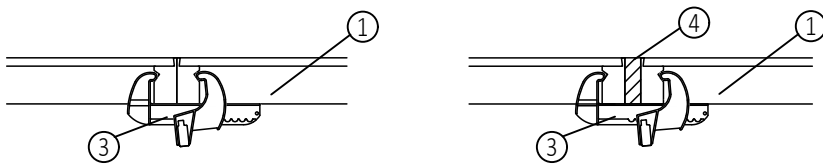

The NOE Toplock X be used at a panel butt joint with a 0-100 mm compensation piece.

#### 5.3 Connection using a compensation panel - 50-250 mm compensation piece

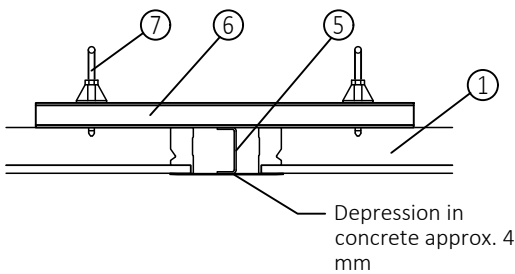

#### Detail of fastening of extension channel

Tying/strutting is done by the panel with spreader bars

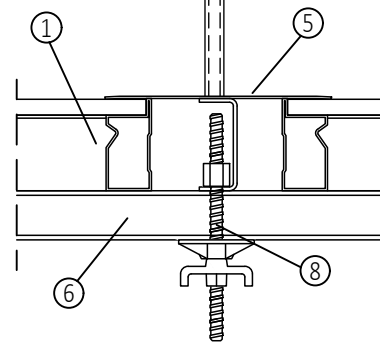

#### 5.4 Element connection with longitudinal tension forces

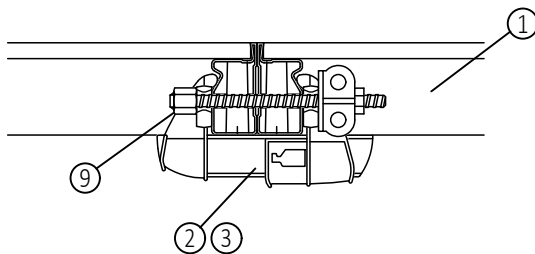

If longitudinal compensation is required, replace the connection bolt by a threaded rod and additional sprint nut

- 1 NOEtop formwork panel
- 2 NOE Toplock Part No. 137976
- 3 NOE Toplock X Part No. 137960
- 4 Compensation piece
- 5 Compensation panel
- 6 Extension channel Part No. 135208
- 7 Hammer-head bolt with handle Part No. 319338

- 8 Tie rod 300 Part No. 670300 with hex headed nut 30 mm Part No. 680900 and wing nut with swivel plate Part No. 691700
- 9 Connection screw Part No. 135019 with waling plate Part No. 691500 and sprint nut Part No. 680580 or with compensation piece tie rod, 2x plates and 2x sprint nuts

5.5 Using the toplock X

- ◆ The panels must be butted together as closely as possible. Fully open the panel lock.

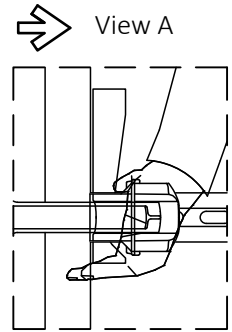
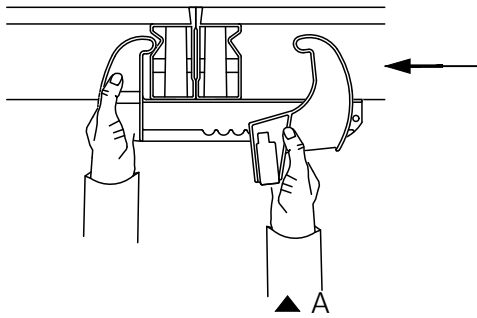

- ◆ Push the opened panel lock horizontally over the panel butt joint whilst lifting the wedge slightly with the fingers. Place the fixed shoe on to the frame of the panel.

- ◆ Push the mobile shoe to close it, until it lies against the profile. Release the wedge to fix the lock and press it downwards.

- ◆ Drive the wedge in with the hammer.

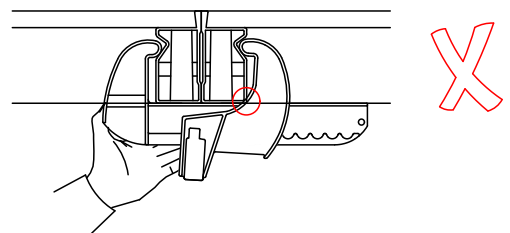
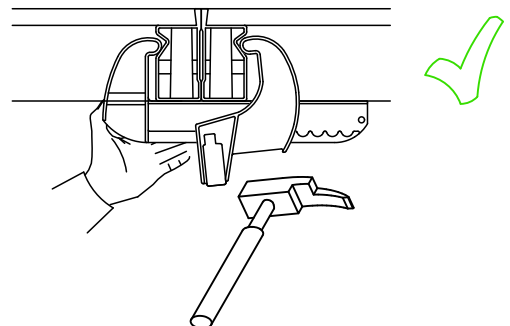

**Number of toplock X required**

Panel height	No. Req.
3310 mm	3
2650 mm	2
1325 mm	2
660 mm	1

→ For cross-sectional view see 4.1 and 4.2

In areas where there are high tension forces (corners, stopends, etc.) an increased the number of connections must be used



5.6 Using the Toplock

- ◆ The panels must be butted together as closely as possible. Push the opened panel lock horizontally over the panel butt joint whilst lifting the wedge slightly with the fingers. Place the fixed shoe on to the frame of the panel.
- ◆ Push the mobile shoe to close it, until it lies against the profile. Release the wedge to fix the lock and press it downwards.
- ◆ Drive the wedge in with the hammer.

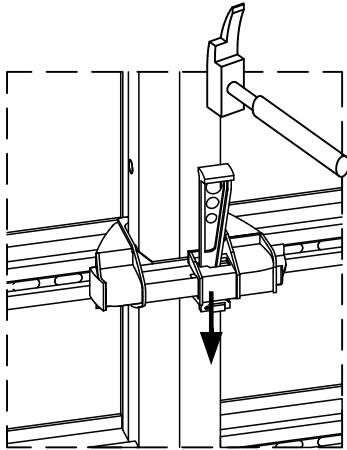
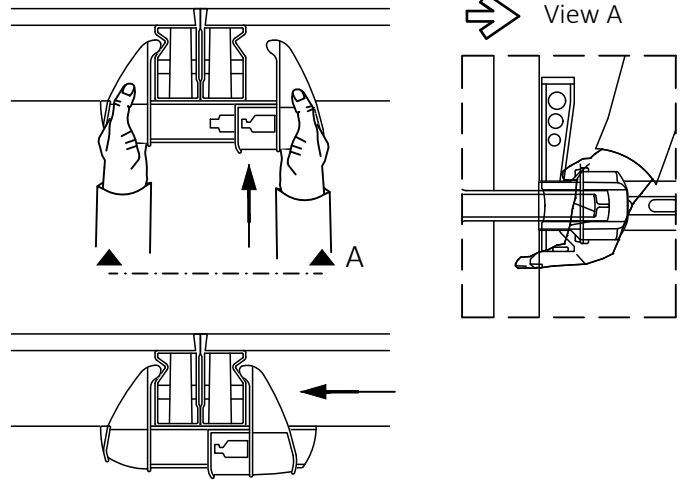

**Numbers of Toplock required**

Panel height	No. Req.
3310 mm	3
2650 mm	2
1325 mm	2
660 mm	1

→ For view in cross-section see 4.1 and 4.2

In areas where there are high tension forces (corners, stopends, etc.) an increased the number of connections must be used

→ Refer to the chapter on corners and transfer of tension forces

5.7 Connections with alignment clamps - with extensions

Extension with end-on panels

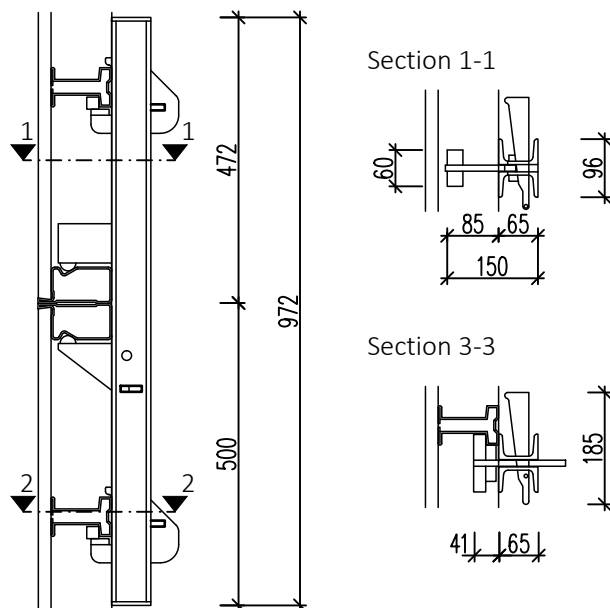

Extension with side-on panels

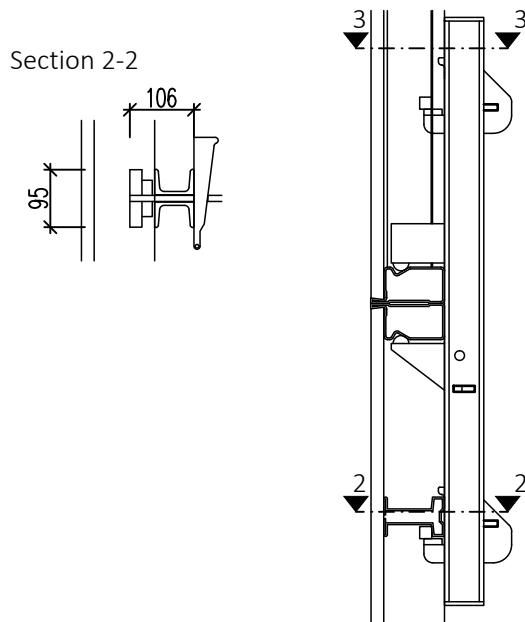

5.7.1 Using alignment clamps

For extensions with end-on panels

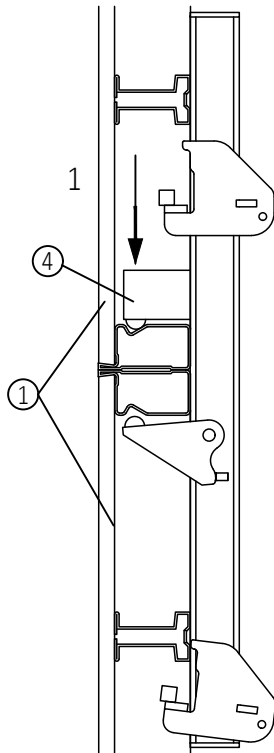

- ◆ Stand the panels on top of one another so that they butt together as closely as possible (for panels assembled on the ground bring them next to one another). Push the alignment clamp over the panel joint and place the fixed shoe on to the frame of the extension panel.
- ◆ To lock the clamp on to the panel butt joint drive in the wedge on the mobile shoe with the hammer.

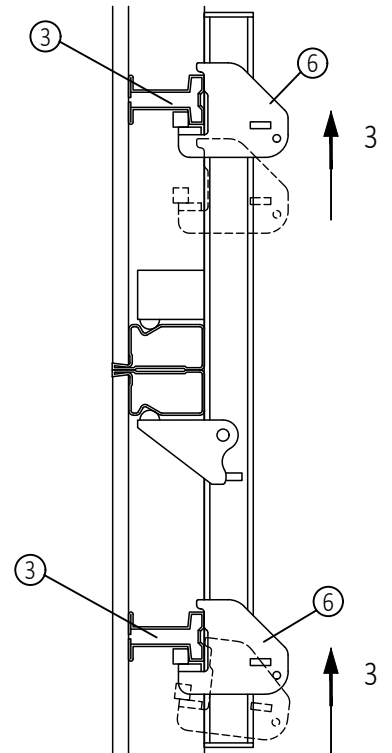
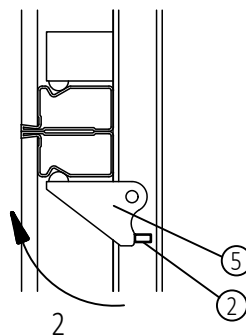

- ◆ Push each of the two outer mobile shoes on to the hat profile so that they enclose the profile

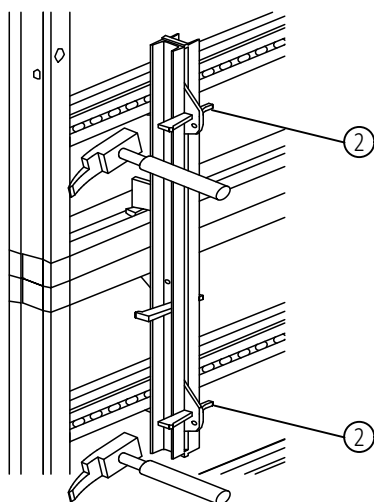

- ◆ and drive in the wedges with the hammer.

- 1 End-on panel
- 2 Wedge
- 3 Hat profile
- 4 Fixed shoe
- 5 Mobile shoe
- 6 Outside mobile shoe

*For extensions with side-on panels*

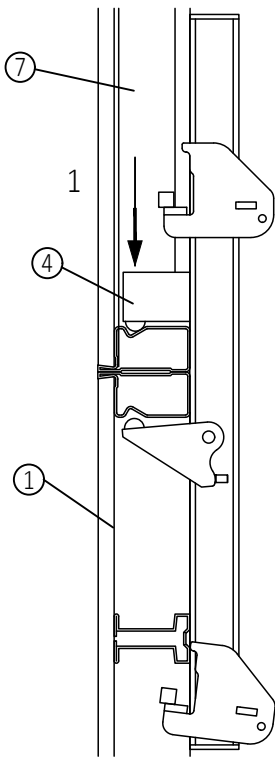

◆ Stand the panels on top of one another so that they butt together as closely as possible (for panels assembled on the ground bring them next to one another). Push the alignment clamp over the panel butt joint and place the fixed shoe on to the frame of the extension panel. Pay particular attention to ensuring that the clamp is close enough to the hat profile of the side-on panel that the nib engages the profile (see below).

◆ To lock the clamp on to the panel butt joint drive in the wedge on the mobile shoe with the hammer.

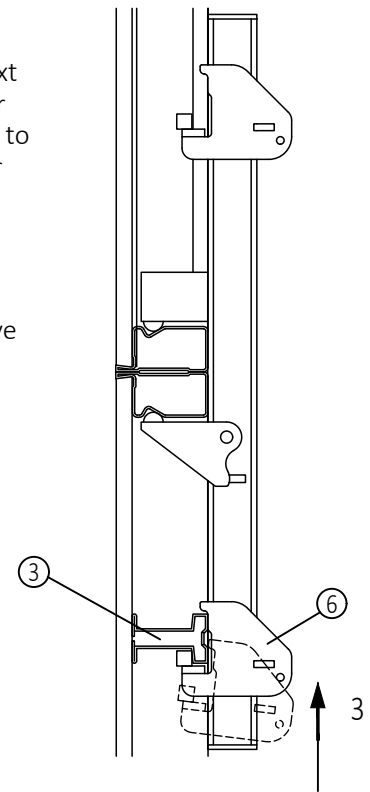
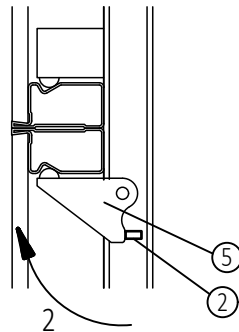

◆ Push the bottom mobile shoe on to the hat profile so that it encloses the profile then drive in the wedge.

The bottom shoe is attached on the case of 2 side-on panels as described above.

◆ With the top shoe, pay particular attention to ensure that the pin engages in the hat profile of the side-on panel and then drive in the wedge.

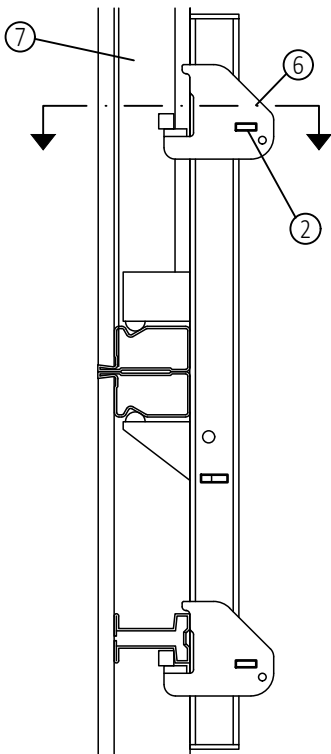

Section through top mobile shoe and hat profile of the side-on panel

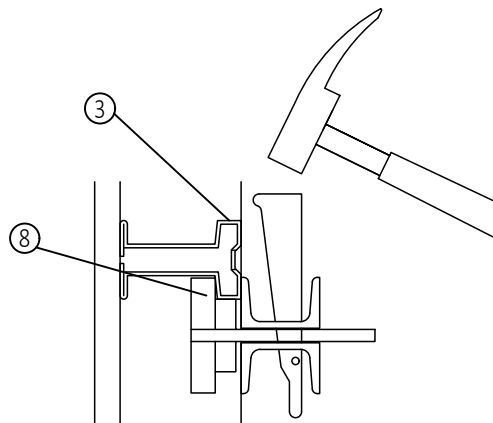

- 1 Standing panel
- 2 Wedge
- 3 Hat profile
- 4 Fixed shoe
- 5 Mobile shoe
- 6 Outside mobile shoe
- 7 Side-on panel
- 8 Pin

## 6. Tying the formwork

The illustrations and part numbers given in this section relate to tie rods  $\varnothing 15$ . If the concrete pressures are higher, tie rods  $\varnothing 20$  should be used and the part numbers appropriately adjusted. The connections between panels are omitted from the sketches.

### 6.1 Without compensation piece (Tie rods pass through panel)

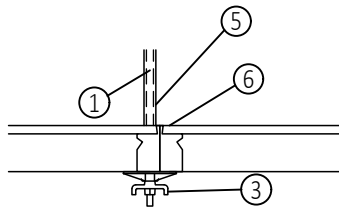

### 6.2 With compensation piece up to 50 mm (Tie rods pass through panel)

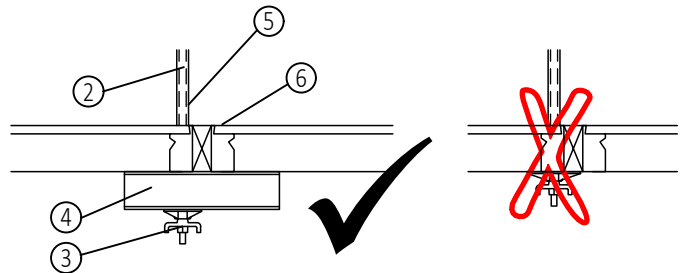

Only tie rods with an approval certificate may be used.

The tie plate must spread the load between both panel frames. If necessary a compensation channel or bracing may be used to spread the tie rod force.

### 6.3 With longitudinal compensation piece up to 250 mm

*Tie rods pass through the compensation piece*

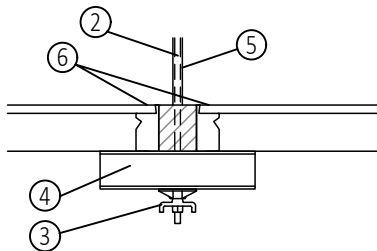

*Tie rods pass through the panel*

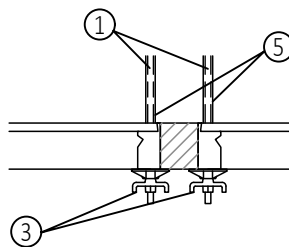

- 1 Tie rod through the panel
- 2 Tie rod through the compensation piece
- 3 Wing nut with swivel plate  
Part No. 691700
- 4 Compensation channel Part No. 135109
- 5 PVC plastic tube Part No. 692400 with  
Support cone Part No. 694900
- 6 Plastic plug for unnecessary tie rod holes  
Part No. 693409

Before concreting check that all the required tie rods are in place and the nuts have been tightened. All tie rods must be installed for panels with cantilevers.

When concreting, do not exceed the maximum permissible concrete pressure:

tie rods $\varnothing 15$	60 KN/m <sup>2</sup>
Tie rods $\varnothing 20$	88 KN/m <sup>2</sup>

For detailed solutions e.g. for extensions, corners, inclined walls, skewed tie rods etc. please refer to the relevant sections.



**6.4 Tie rods over the top of the panel**  
with tying claws e.g. for extensions

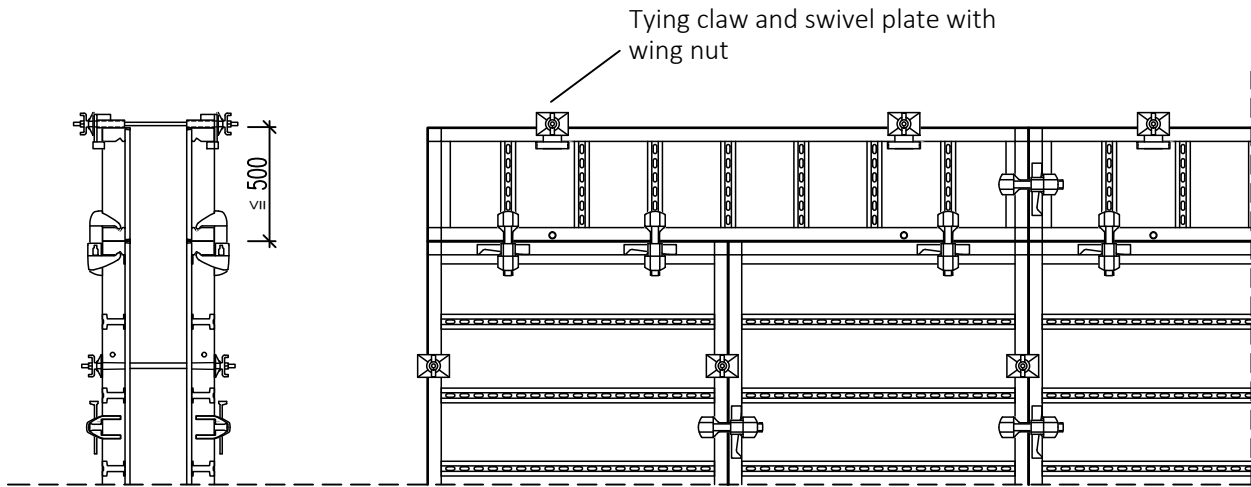

**6.5 Tie rods with multi-claw for change in direction of panels**  
(Alternatively a version with tying claw Part No. 137500 can be used)

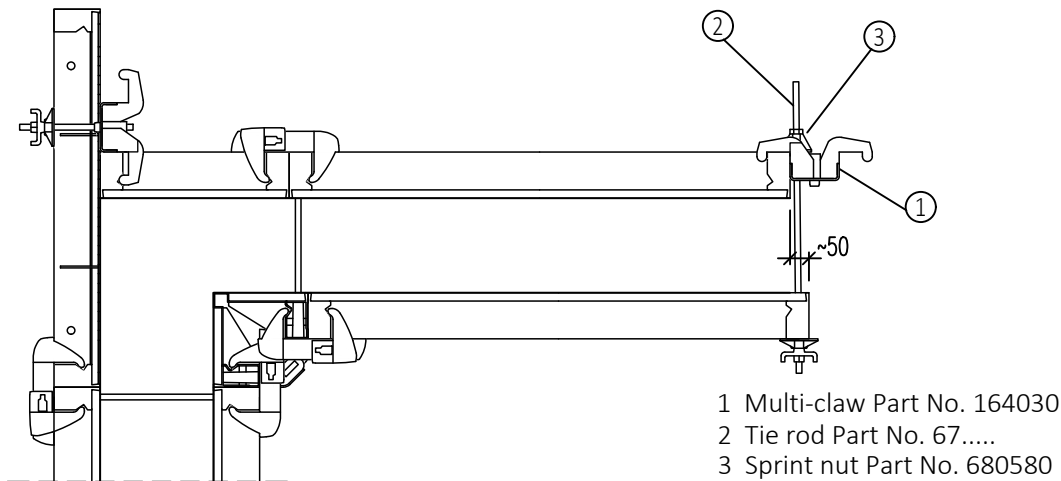

**6.6 Skewed tie rods**

◆ In edge profile

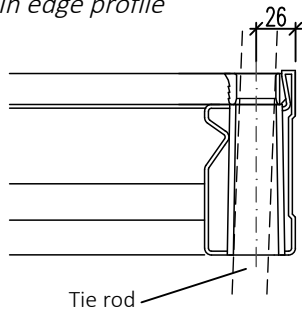

Skewed tie rod  
For  $\varnothing 20$  max. 2.2° (equiv. 38 mm/m)  
For  $\varnothing 15$  max. 5.1° (equiv. 89 mm/m)

◆ In bracing profile of the large panel

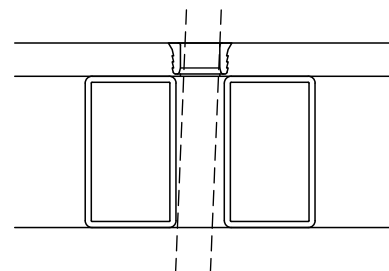

Skewed tie rod  
For  $\varnothing 20$  max. 2.3° (equiv. 40 mm/m)  
For  $\varnothing 15$  max. 5.1° (equiv. 89 mm/m)

## 7. Corner solutions

### 7.1 Corner 90°

#### 7.1.1 Corner 90° - with EC panel ECP

For arrangements to transfer tension forces observe the requirements of Chapter 9!

For wall thicknesses<sub>1</sub>  
 150, 200, 250, 300, 350, 400, 450 mm (L=112.5 mm = centre of 1st hole - ECP normal)  
 125, 175, 225, 275, 325, 375, 425 mm (L=137.5 mm - ECP turned)

Hole pattern in ECP with holes at 50 mm spacing. By turning the ECP, a 25 mm spacing is possible (for 3310 and 660 mm high panels, tie rods cannot then pass through the ECP, as the height of the series of holes is unsymmetrical).

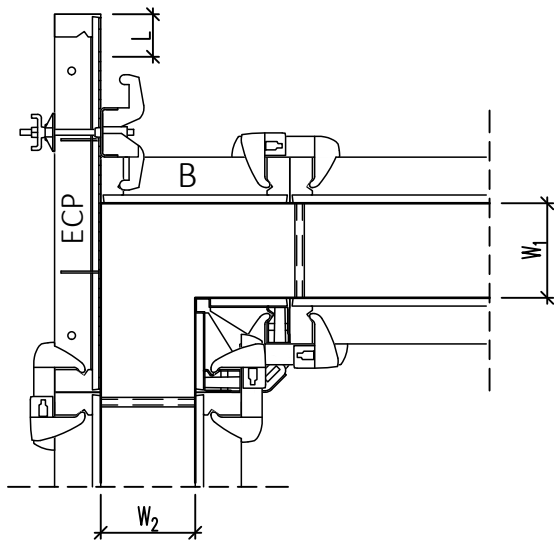

Wall thickness	W <sub>1</sub>	W <sub>2</sub>	
	External corner panel ECP	Make-up panel B [mm]	* Compensation piece [mm]
125	Turned	400	25 Inside
150	Normal	400	---
175	Turned	400	25 Outside
200	Normal	450	---
225	Turned	500	25 Inside
250	Normal	500	---
275	Turned	500	25 Outside
300	Normal	550	---
325	Turned	550	25 Outside
350	Normal	550	50 Outside
375	Turned	550	75 Outside
400	Normal	550	100 Outside
425	Turned	750	75 Inside
450	Normal	750	50 Inside

The corner detail may also be applied to the mirror image of the one shown.

\*Compensation piece inside: B>250+W, compensation piece outside: B<250+W

For the installation of the compensation piece see Chapters 5 and 6.

### Detail of corner connection

Plan

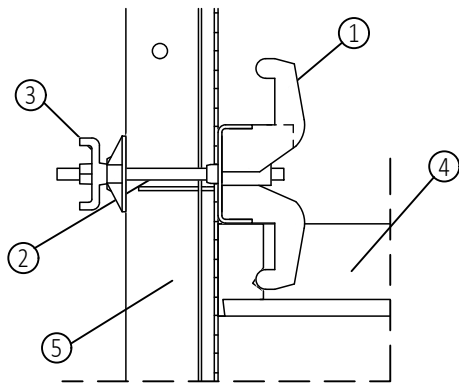

Section

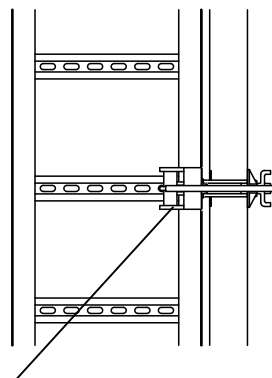

**Number of connections**

Panel height	Number
3310 mm	4
2650 mm	3
1325 mm	2
660 mm	1

- 1 Multi-claw Part No. 164030
- 2 Tie rod 300 mm Part No. 670300
- 3 Wing nut with swivel plate Part No. 691700
- 4 NOEtop panel
- 5 NOEtop EC panel 1000

Multi-claw pushed over hat profile



7.1.2 Corner 90° - with external corner angle ECA

◆ ECA clamped on

⇒ Wall thicknesses up to 350 mm

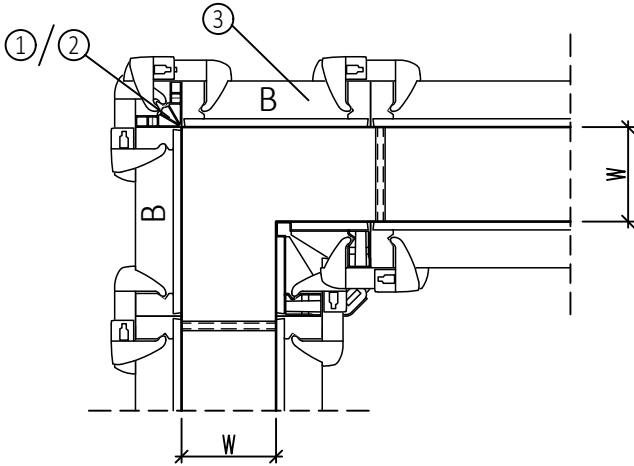

◆ ECA bolted on

Connection bolts are used with steel ECAs, M16 bolts with aluminium ECAs, see detail.

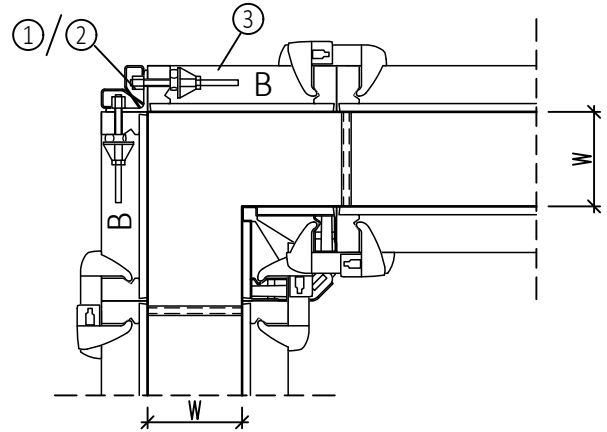

☞ For arrangements to transfer tension forces observe the requirements of Chapter 9!

Number of connections		
Panel height	Number	
3310 mm	4	
2650 mm	4	
1325 mm	2	
660 mm	2	

The number of connections is equal to the number of transverse holes in the ECA.

◆ Detail Bolted connection Steel ECA

◆ Detail Bolted connection Aluminium ECA

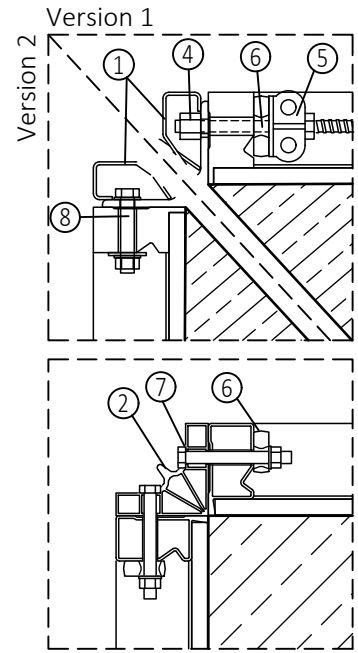

NOEtop make-up panels B for wall thickness W

Wall thickness W	Width B (panel)
150 mm	400 mm
200 mm	450 mm
250 mm	500 mm
300 mm	550 mm
500 mm	750 mm *
750 mm	1000 mm *

\*ECA bolted

☞ Connections using wedge clamp Part No. 138090 cannot be used with ECA ALU!

For dimensions of panels and compensation pieces for other wall thicknesses see 7.1.1 Corner solutions with ECP (W<sub>2</sub>)

- 1 Steel ECA
- 2 Aluminium ECA
- 3 Formwork make-up panel corner
- 4 Connection bolt Part No. 135019
- 5 Sprint nut Part No. 680580
- 6 Waling plate Part No. 691500
- 7 M16x140 Part No. 314250
- 8 M18x100 Part No. 318801

7.1.3 Corner 90° - Stripping formwork from an internal corner

The angle of the internal corner element can be reduced for stripping formwork.

Corner with formwork in place

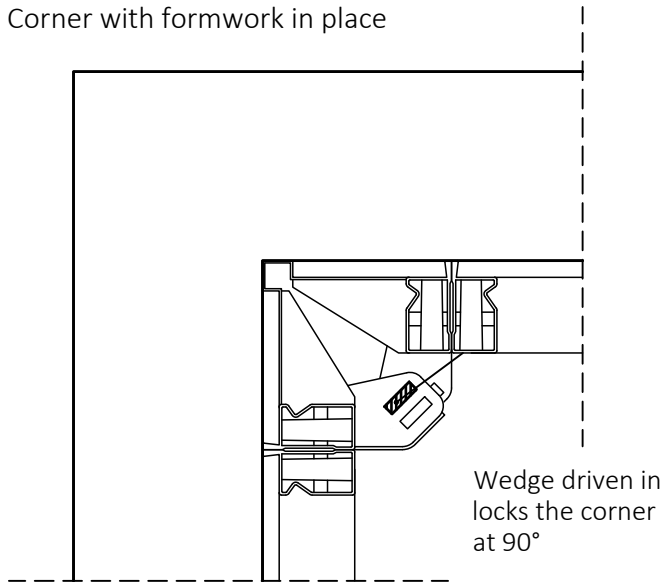

Corner being stripped

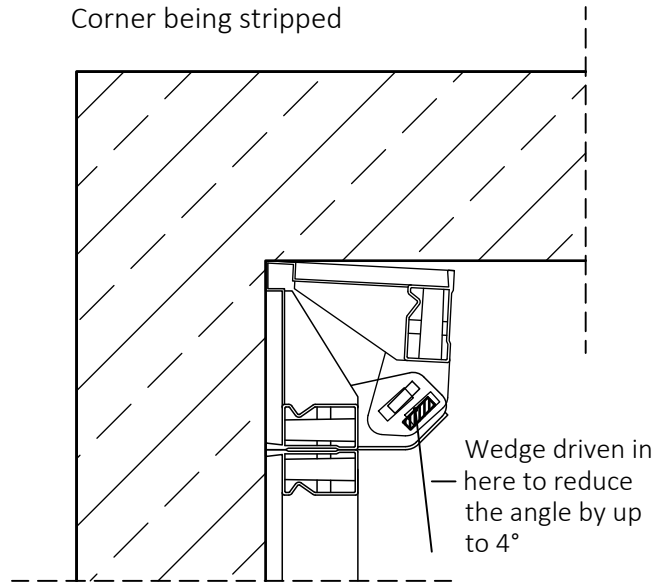

7.2 Corner 60-180°

Corner solution with adjustable corner elements

Adjustable internal corner

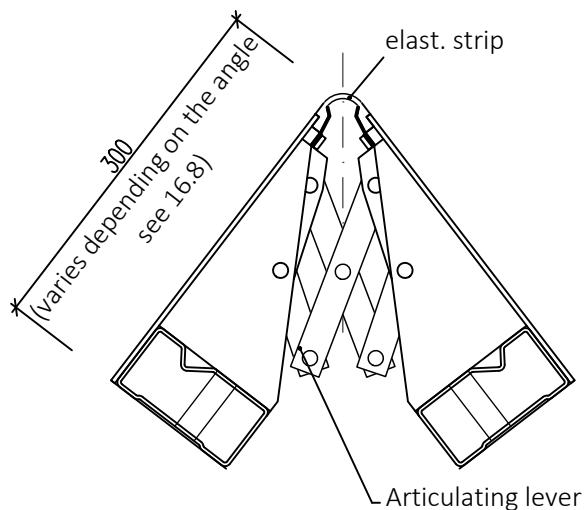

Adjustable external corner

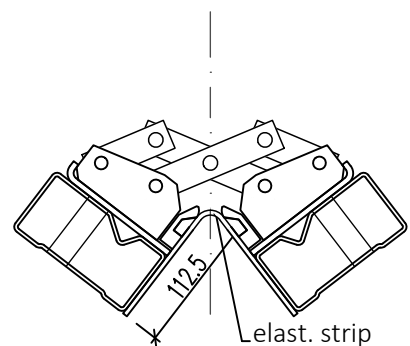

The adjustable corners are locked by articulating levers. The elastic strips form a rounded corner without leaving the impression of a hinge.

Table for acute- and obtuse-angled corners

Version I: Compensation piece internal  $A_i$

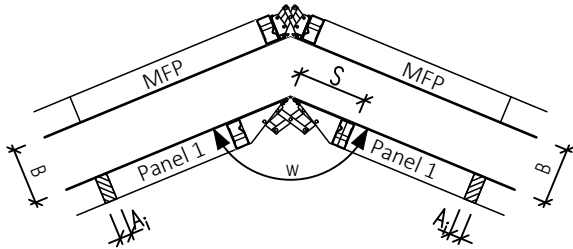

Version II: Compensation piece external  $A_a$

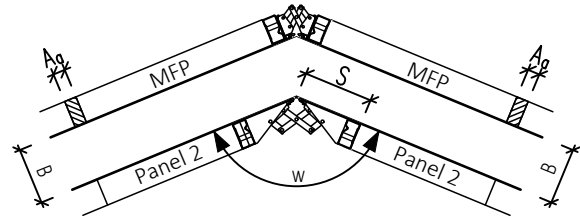

Version I: Compensation piece internal ( $A_i$  in mm)

Wall thickness B in mm	Angle w							
	60°	70°	80°	90°	100°	120°	135°	150°
150	104	$A_a$	$A_a$	$A_a$	0	47	73	96
200	17	85	137	$A_a$	$A_a$	18	52	82
240	$A_a$	28	90	138	$A_a$	$A_a$	36	72
250	$A_a$	$A_a$	78	128	$A_a$	$A_a$	32	69
300	-	$A_a$	18	78	129	$A_a$	11	56
350	-	-	$A_a$	28	87	$A_a$	$A_a$	42
400	-	-	$A_a$	$A_a$	45	153	$A_a$	29
Panel 1	750 mm						1000 mm	

Compensation pieces > 100 mm must be split into two.

Version II: Compensation piece external ( $A_a$  in mm)

Wall thickness B in mm	Angle w							
	60°	70°	80°	90°	100°	120°	135°	150°
150	$A_i$	93	53	21	0	$A_i$	$A_i$	$A_i$
200	$A_i$	$A_i$	113	71	37	$A_i$	$A_i$	$A_i$
240	52	$A_i$	$A_i$	111	71	5	$A_i$	$A_i$
250	69	14	$A_i$	121	79	11	$A_i$	$A_i$
300	156	57	$A_i$	$A_i$	133	40	$A_i$	$A_i$
350	-	129	42	$A_i$	$A_i$	68	10	$A_i$
400	-	-	101	22	$A_i$	97	31	$A_i$
Panel 2	750 mm						1000 mm	

Compensation pieces > 100 mm must be split into two.

For large wall thickness refer to 13.3.

7.2.1 Corner 60-180° with adjustable corners and multifunctional panel MFP

For panel heights 2650 and 1325 mm without additional bracing

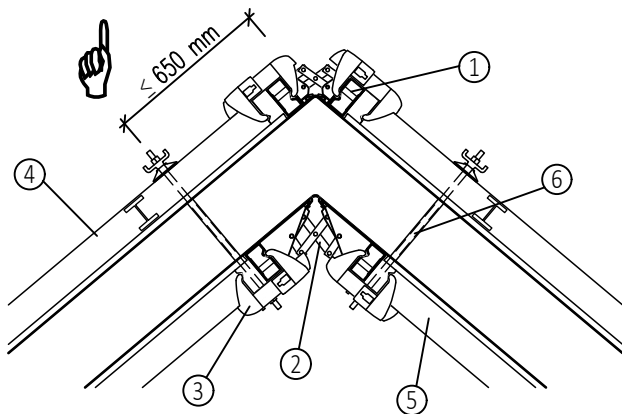

- 1 Adjustable external corner
- 2 Adjustable internal corner
- 3 NOE Toplock
- 4 MFP
- 5 NOEtop standard panel
- 6 Tie rod

Note:



- Adjustable corners can be used for angles between 60-180°
- Tie rod distance max. 650 mm from corner
- For acute angles and large wall thickness place tie rods through wall corner or use additional bracing!
- For angles > 100° prop the internal corner!

7.2.2 Corner 60-180° with adjustable corners and standard panels

For large wall thickness refer to 13.3.

With additional bracing for tie rods and folding parts

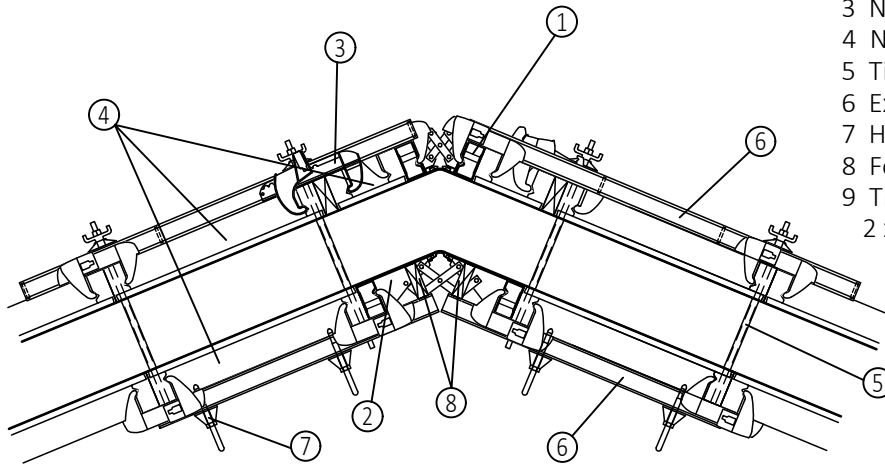

- 1 Adjustable external corner
- 2 Adjustable internal corner
- 3 NOE Toplock X
- 4 NOEtop standard panel
- 5 Tie rod
- 6 Extension channel or alignment channel
- 7 Hammer-head bolt
- 8 Folding parts
- 9 Tie rod with 2 x plates and 2 x sprint nuts

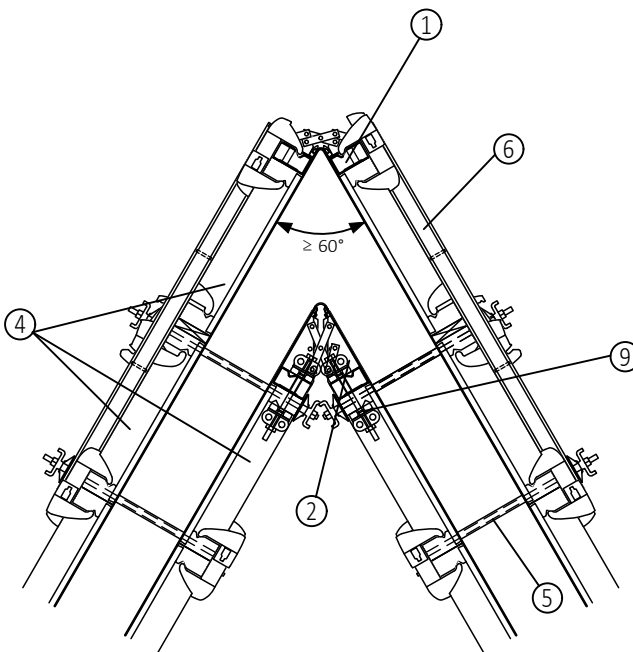

Number of bracings on the internal side		
	<u>Panel height</u>	No.
	3310 mm	Req.
	2650 mm	4
	1325 mm	3
	660 mm	2
		1

The number of bracings on the external side depends on the number and positions of the tie rod holes.

Note:

- Adjustable corners can be used for angles between 60-180°
- Tie rod distance max. 650 mm from corner
- For acute angles and large wall thickness place tie rods through wall corner or use additional bracing!
- For angles > 100° prop the internal corner!

### 8. Stop-end formwork

*Following panels to be clamped with increased numbers of locks as to take the horizontal forces from the stop-end; this applies particularly to smaller sized panels (see 9 about tension forces at external corners).*

◆ With connection bolts through the transverse holes in the edge profile

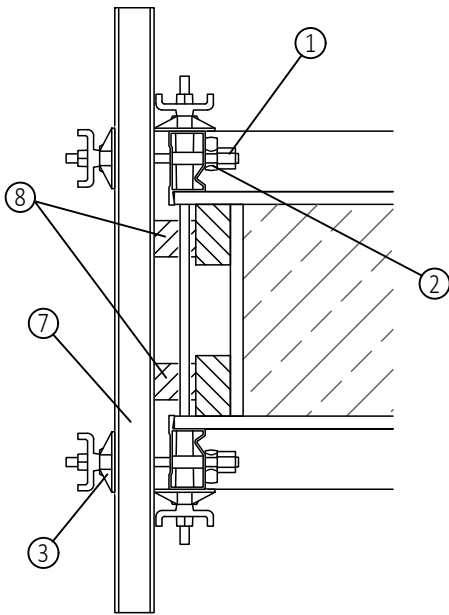

◆ With stop-end holder Part No. 164032 at edge profile independent of transverse holes.

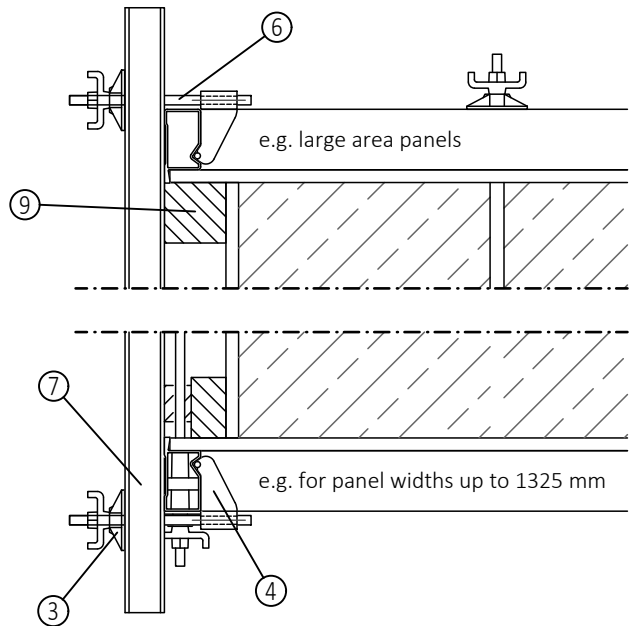

Number of extension channels



Panel height [mm]	Number of ext. channels at height	max. wall thickness [mm]
3310	3	300
	4	600
2650	3	500
	4	600
1325	2	600
660		

◆ With stop-end holder Part No. 164036 at edge profile independent of transverse holes.

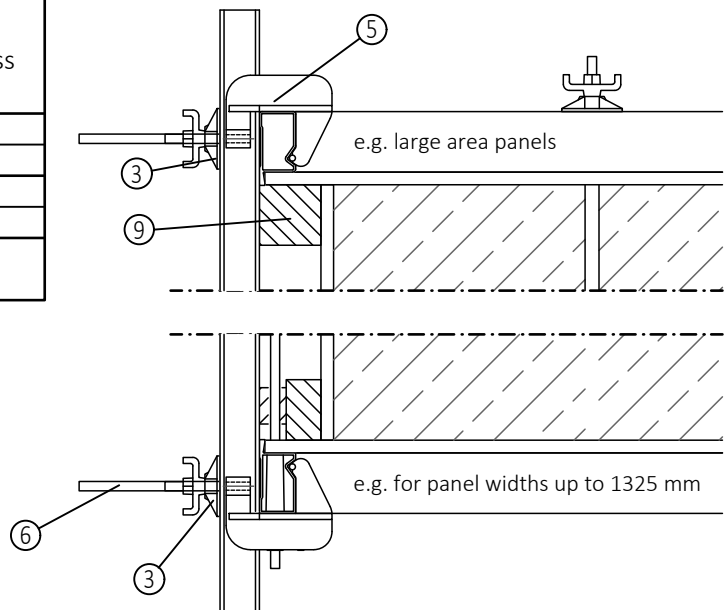

- 1 Connection bolt Part No. 135019
- 2 Waling plate Part No. 691500
- 3 swivel plate with wing nut Part No. 691700
- 4 Stop-end holder 15 kN Part No. 164032
- 5 Stop-end holder 25kN Part No. 164036
- 6 Tie rod Part No. 670300
- 7 Extension channel Part No. 135208
- 8 Wedge
- 9 Timber - dimensions determined on site

### 9. Arrangements to transfer tension forces at external corners and stopend forms

External corner

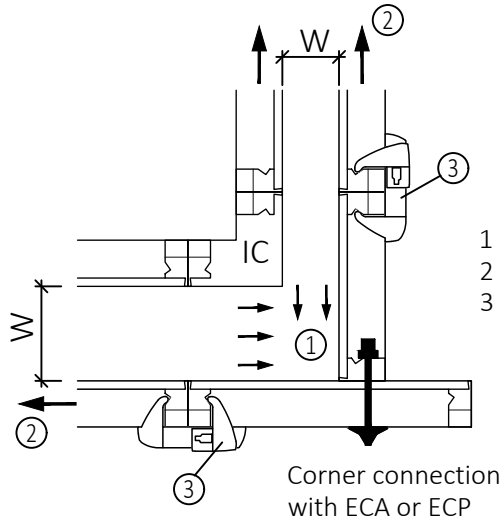

- 1 Concrete pressure
- 2 Resulting tension force
- 3 NOE Toplock

Durch Querbohrungen, die sich in den Randprofilen zwischen zwei Hutprofilen befinden, können Zugkräfte bis 30 kN aufgenommen werden.

Stopend form

End formwork of ECP or bracing

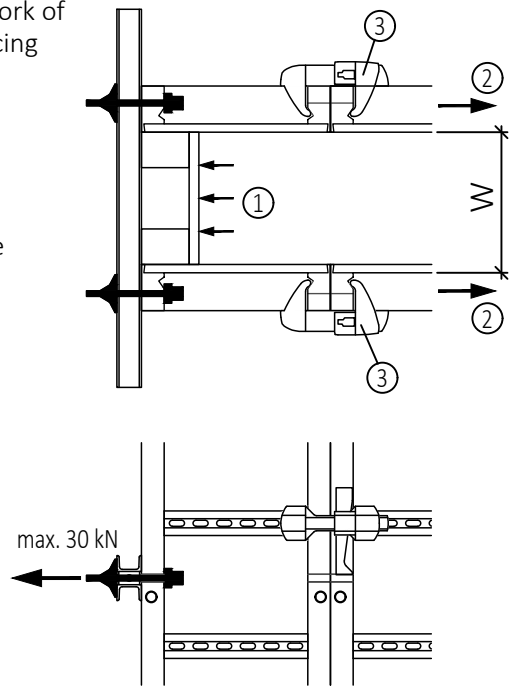

Depending on the concrete pressure and wall thickness more locks (or similar devices) than are necessary for panel connection may be required to transfer the tension forces (see table).

Tables for the number of additional connections to transfer tension forces

External corner

Height mm	No. of connections at normal butt joint	W up to 350 mm		W up to 500 mm	
		No. of toplock X	No. of Toplock	No. of toplock X	No. of Toplock
2650	2	-	-	-	+1
3310	3	-	-	-	+1
3975	4	-	+1	-	+1
4635	5	-	+1	+1	+2
5300	5	+1	+2	+2	+3
5960	6	+1	+2	+2	+4
6625	6	+1	+3	+3	+5

Stopend form

Height mm	No. of connections at normal butt joint	W up to 500 mm	
		No. of toplock X	No. of Toplock
2650	2	-	-
3310	3	-	-
3975	4	-	-
4635	5	-	+1
5300	5	-	+1
5960	6	-	+2
6625	6	-	+2

The number of additional connections is given for a concrete pressure of 88 kN/m<sup>2</sup>.

Instead of providing the additional number of locks, the panels can also be connected together through transverse holes with the appropriate number of bolts. It may be necessary to connect several panels together in this way.

Further connections will be required for larger wall thicknesses or formwork heights.



## 10. Formwork connection solutions

### 10.1 Connection transversely to an existing wall

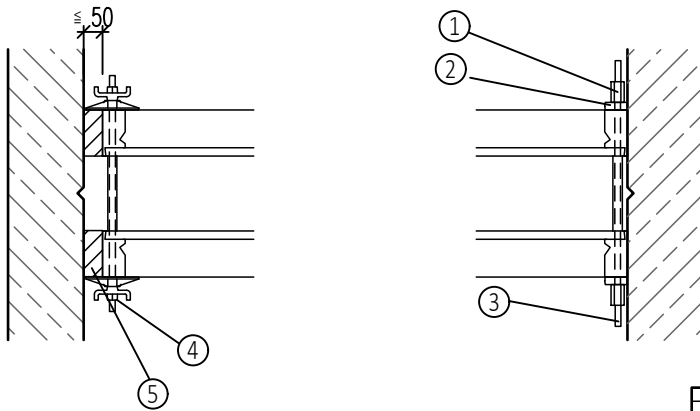

- 1 Hexagonal nut Part No. 681000
- 2 Waling plate Part No. 691500
- 3 Tie rod  $\varnothing$ 15 mm Part No. 67....
- 4 Tie with wing nut with swivel plate Part No. 691700
- 5 Timber
- 6 Compensation channel Part No. 135109
- 7 NOE Toplock X
- 8 Water-stop

with NOEtop MFP or ECP

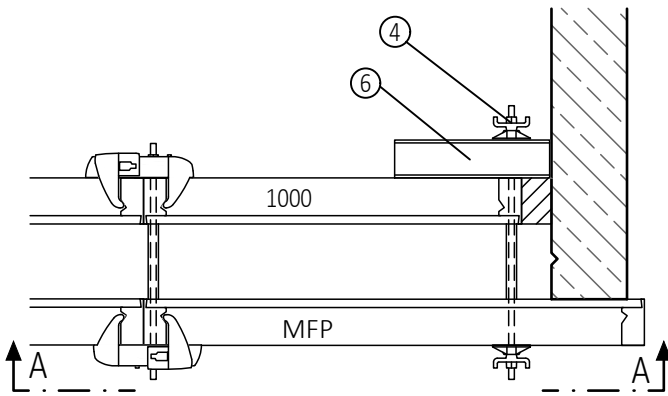

Elevation A-A

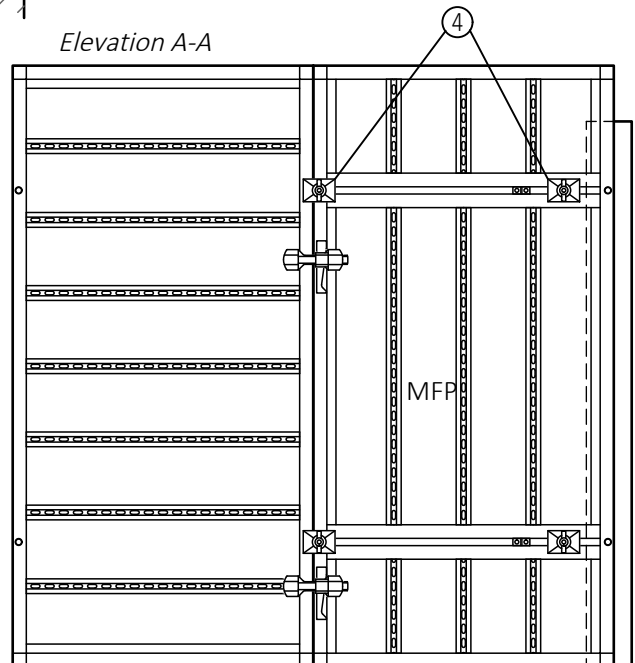

### 10.2 Connection longitudinally to an existing wall

with 25mm thick panels

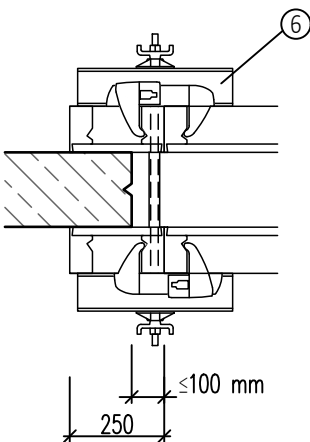

with timber

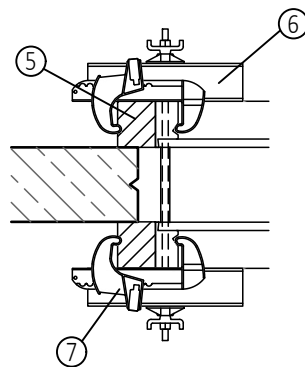

with NOEtop MFP (alternatively ECP) e.g. with water-stops

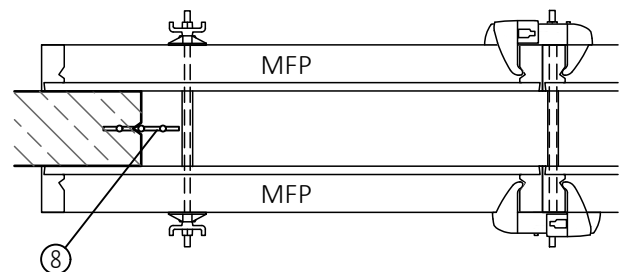

If an ECP is used, the tie rods pass through the holes in the channels.

10.3 Connections forming T-walls

For clarity the connections between panels have been omitted from the diagrams!

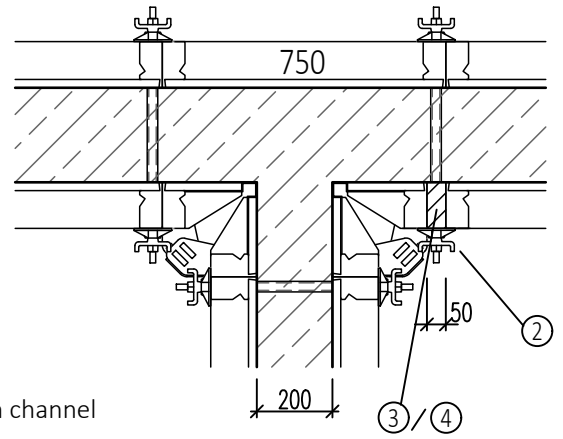
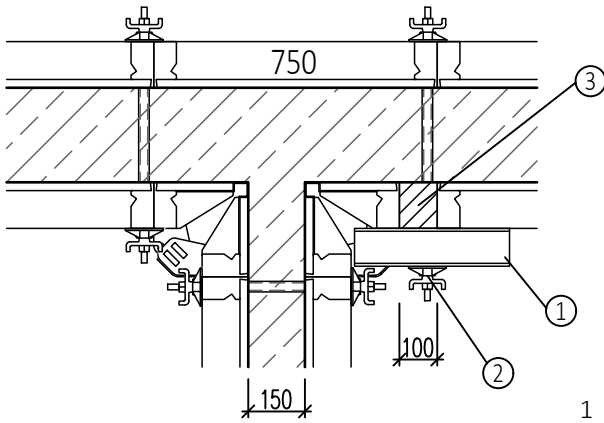

- 1 Compensation channel
- 2 Tie rod
- 3 Timber filler
- 4 Filler piece 50 mm

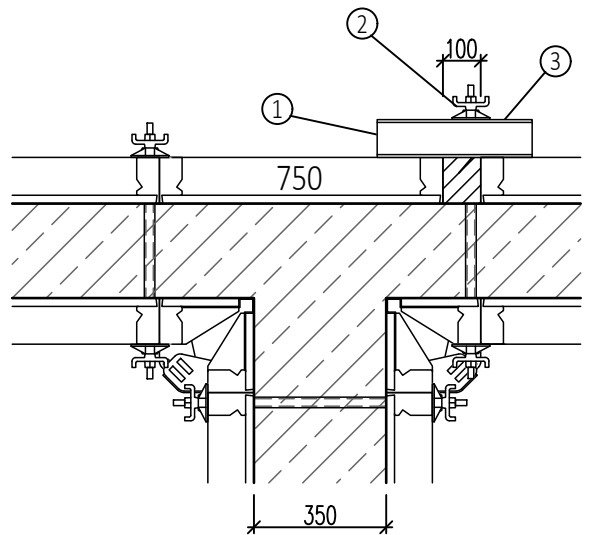
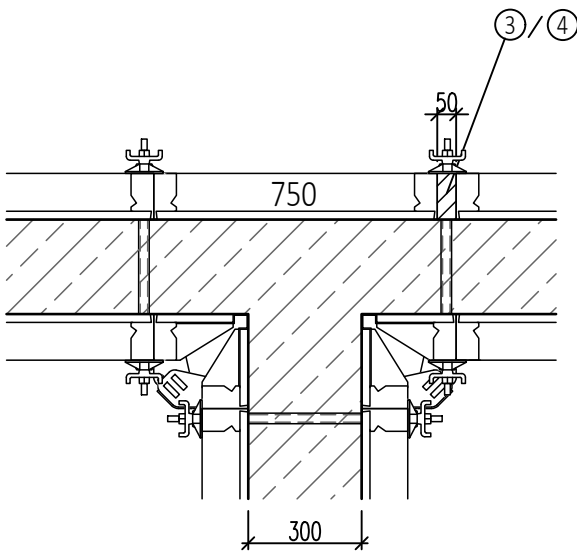
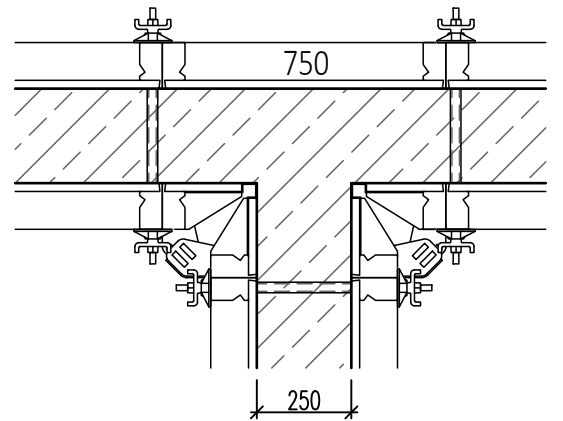
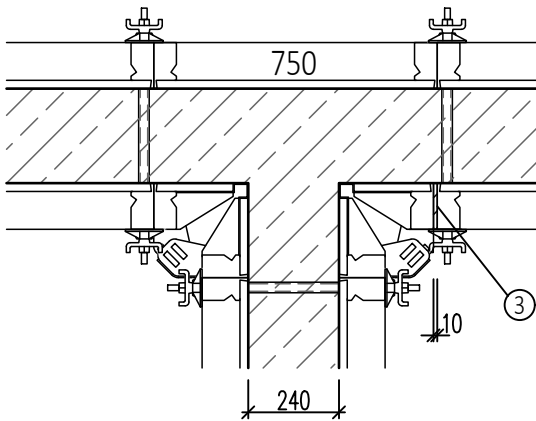

10.4 Pilasters

Projections up to 250 mm

For clarity the connections between panels have been omitted from the diagrams!

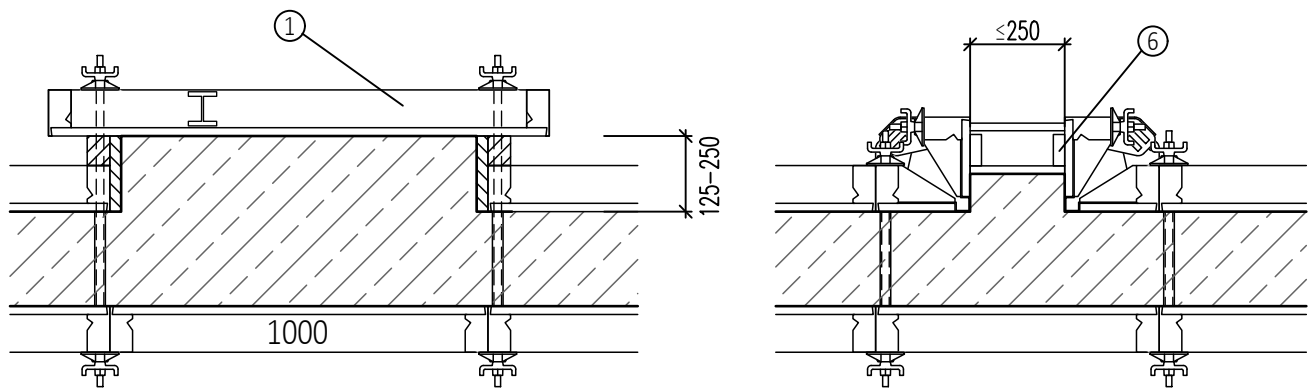

Projections greater than 250 mm

- 1 NOEtop MFP
- 2 NOEtop ECP
- 3 NOEtop ECA
- 4 Compensation channel Part No. 135109
- 5 Multi-claw Part No. 164030
- 6 Stopend timber

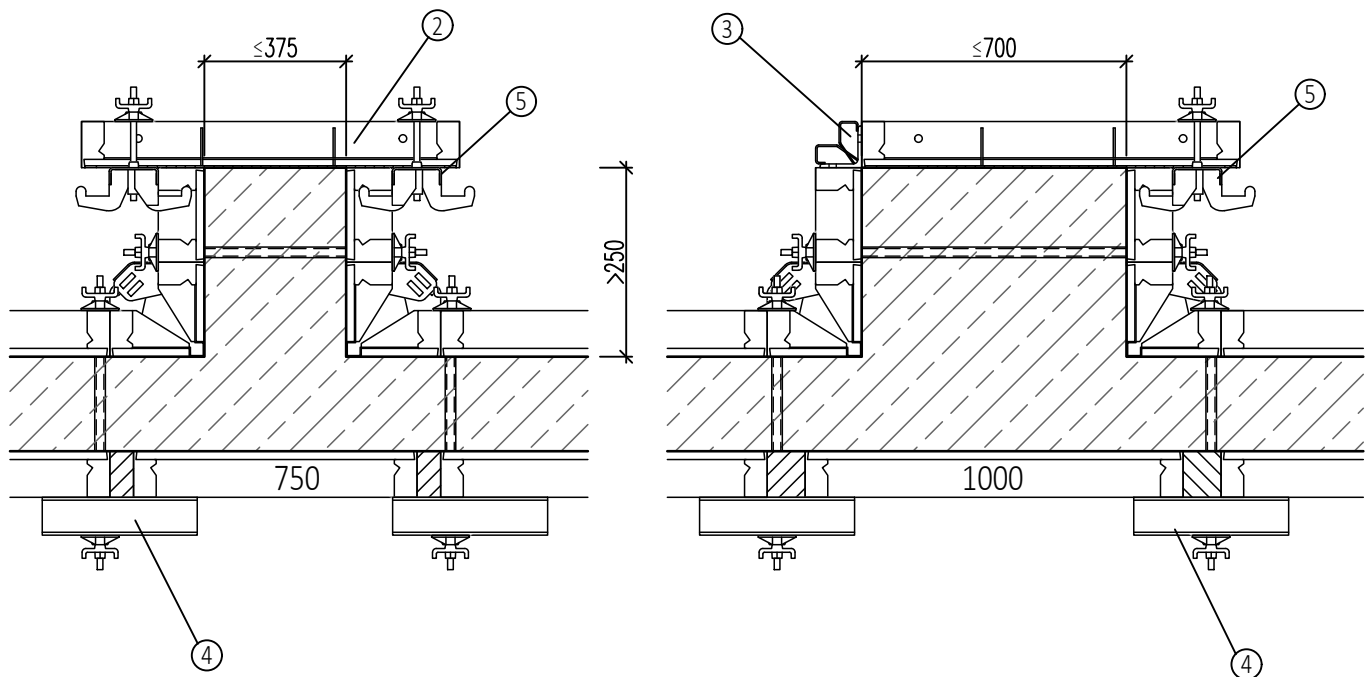

# NOEtop formwork



## 10.5 Wall change in thickness

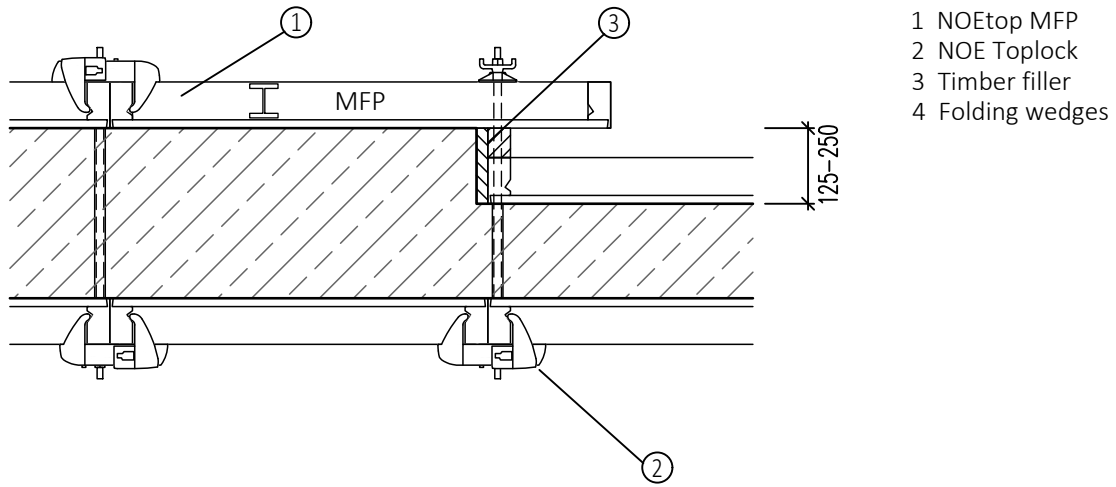

## 10.6 Wall step

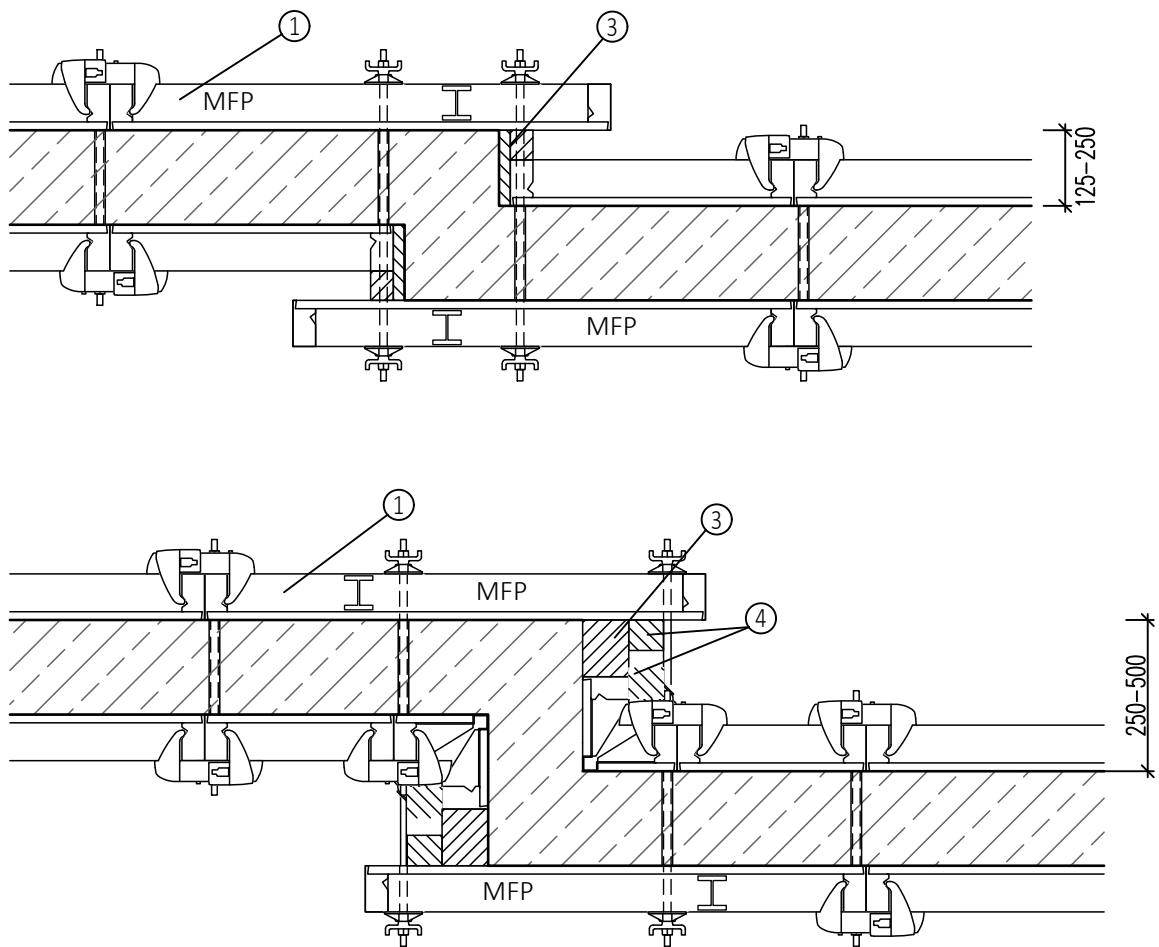

## 11. Extending panels

All panels can be combined end-on or side-on. The continuous edge profile allows element connections to be made in practically any position.

### 11.1 Overview of possible combinations

#### Extending panels end-on

Height increment 660 mm for panel widths 250-1325 mm, corner elements, compensation panels. Higher formwork requires additional bracing at the butt joint.

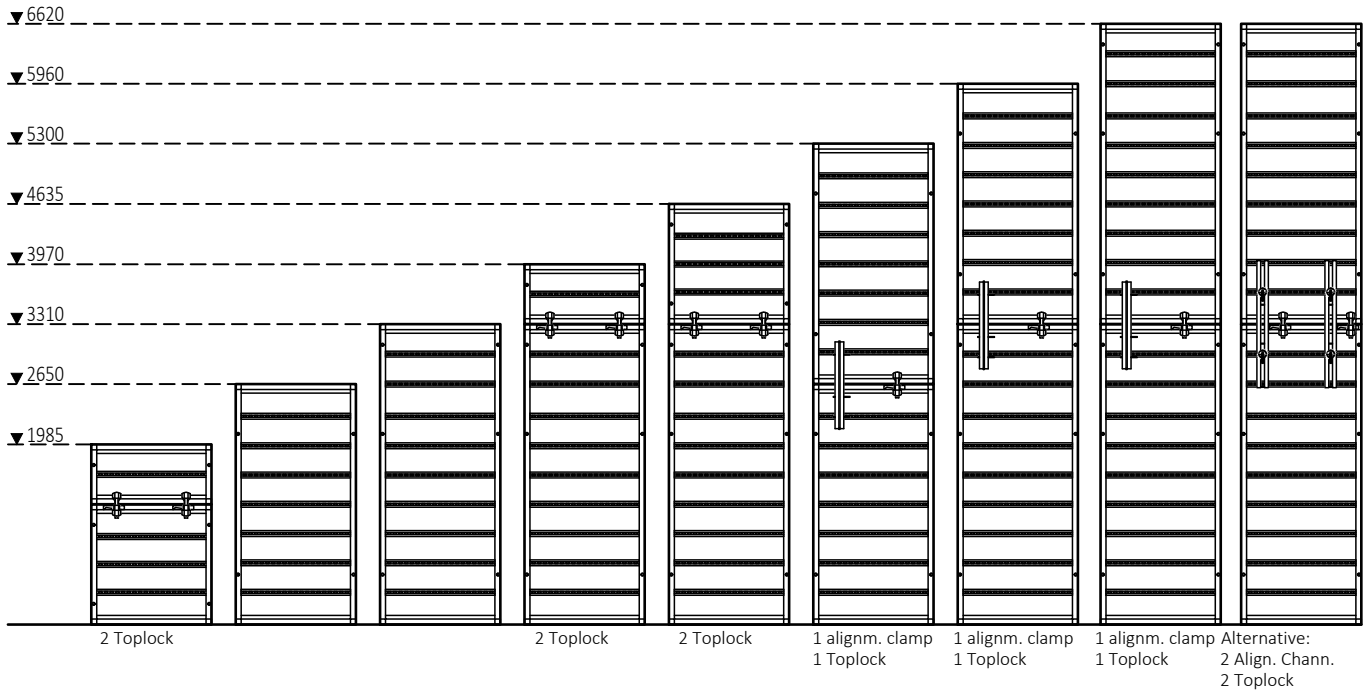

#### Extending panels side-on

Height increment 250 mm for panel widths 1325, 2650, 3310 and 5300 mm with uniform vertical butt joints in the panel pattern.

With the appropriate bracing, extensions of further panels can be made side-on.

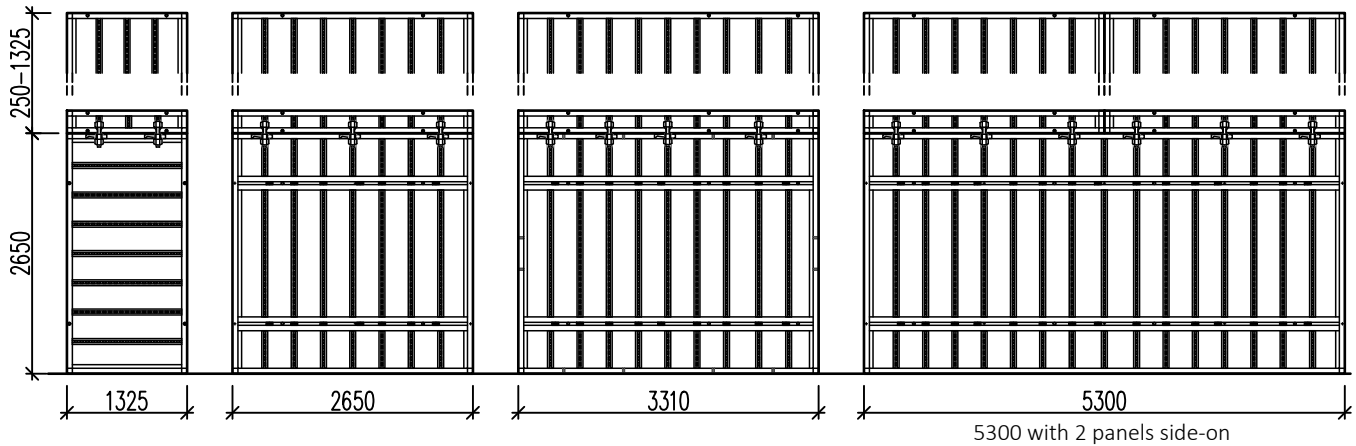

# NOEtop formwork



## 11.2 Formwork extensions using panels end-on

### 11.2.1 Extending with end-on panels 660 mm high

Elevation (walkway brackets not shown)

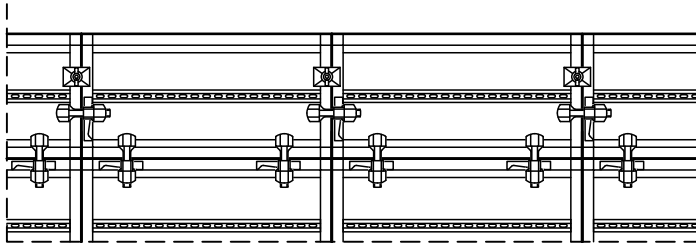

Number of horizontal connections

- Up to panel width 550 mm 1 Toplock per panel
- From panel width 750 mm 2 Toplock per panel

Section

With tying claws and sprint nuts, alternatively tie rods can be passed through panels.

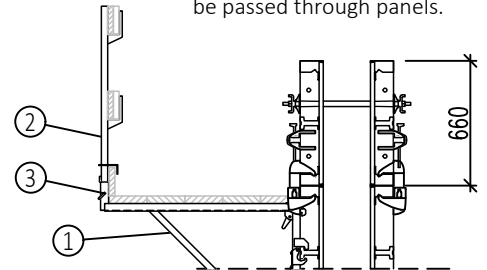

The attached platform brackets (spacing, number) and selection of scaffold planks must comply with regulations for working scaffolds !  
 → see 15.2

### 11.2.2 Extending with end-on panels 1325 mm high

Elevation (walkway brackets not shown)

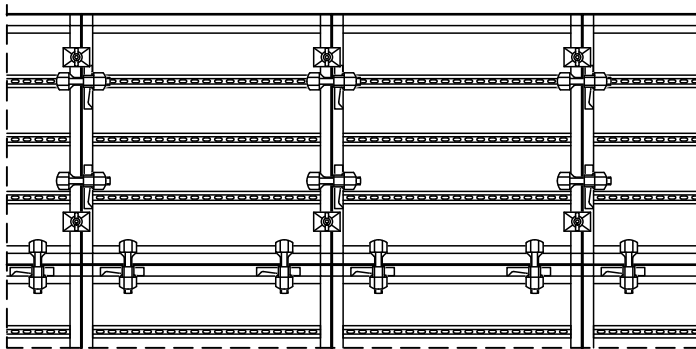

Number of horizontal connections

- Up to panel width 550 mm 1 Toplock per panel
- From panel width 750 mm 2 Toplock per panel

Section

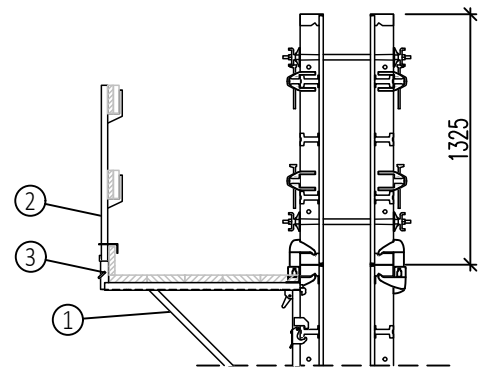

The attached platform brackets (spacing, number) and selection of scaffold planks must comply with regulations for working scaffolds !  
 → see 15.2

- 1 Walkway bracket Part No. 552204
- 2 Handrail tube Part No. 111400 or Part No. 111403
- 3 Plug Part No. 890834

11.2.3 Extending with end-on panels 2650 or 3310 mm high

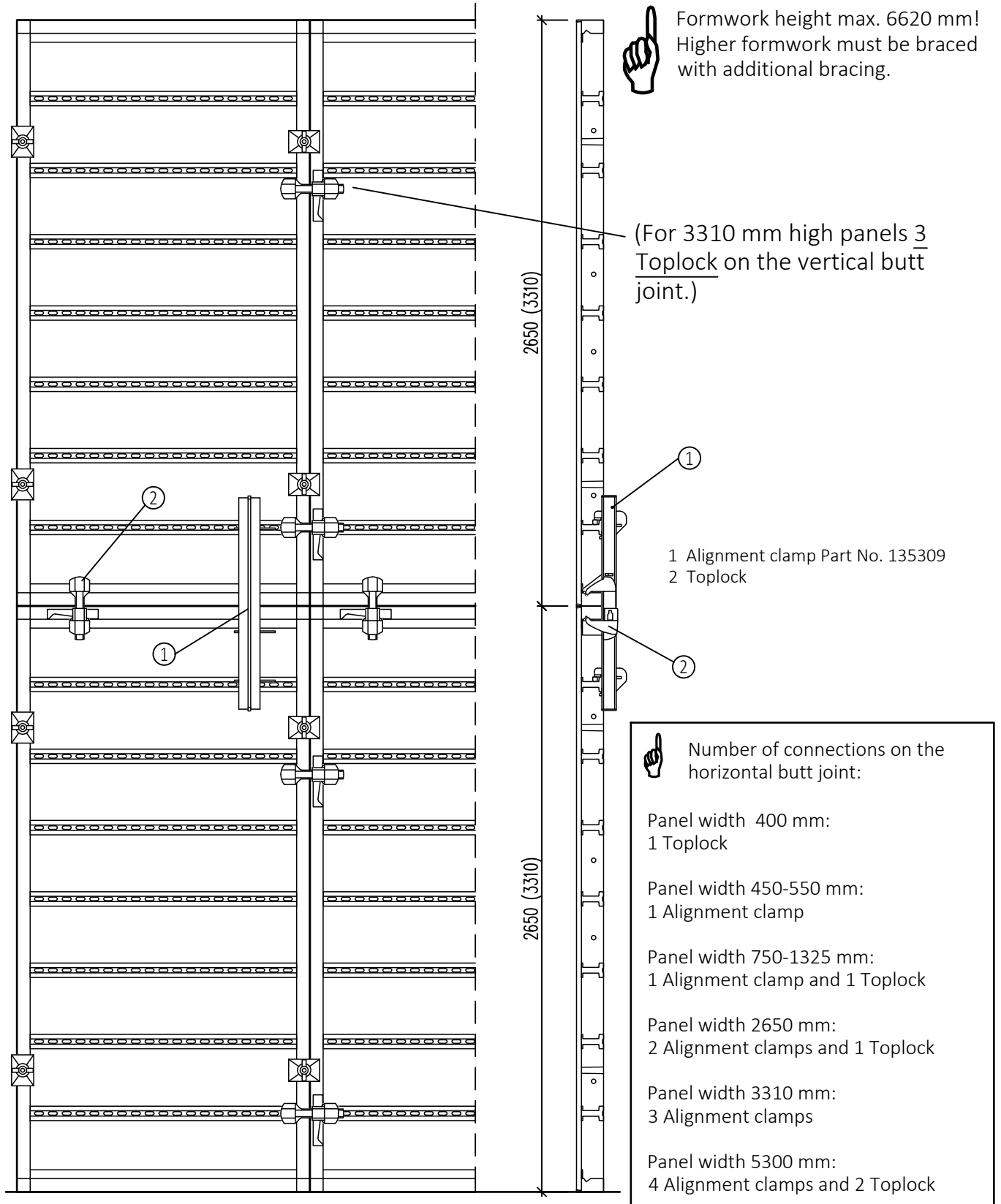





11.3 Formwork extensions with side-on panels

11.3.1 250 mm extension with Toplock

Elevation

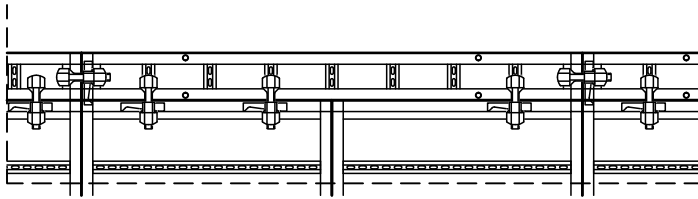

Formwork extension with Toplock. The extension can be without tie rods if 3 Toplock are installed on the 2650 mm wide panel.

Section

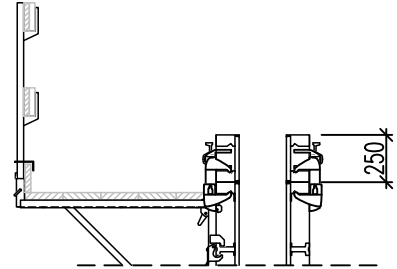

Attaching the walkway bracket to end-on panels.

11.3.2 400-500 mm extension with Toplock

Elevation

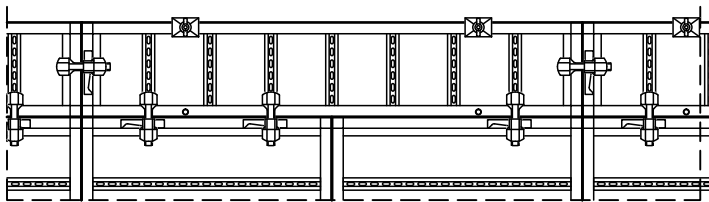

3 Toplock are attached to 2650 mm wide table. Tie rods at the top only for side-on panels.

Section

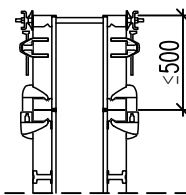

Attach the walkway bracket to end-on or side-on panels.

Alternatively:

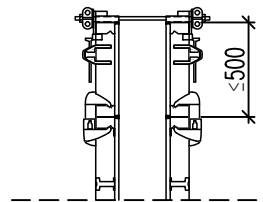

The side-on panel is connected with tying claws and sprints.

11.3.3 400-500 mm extension with alignment clamps and Toplock

Elevation

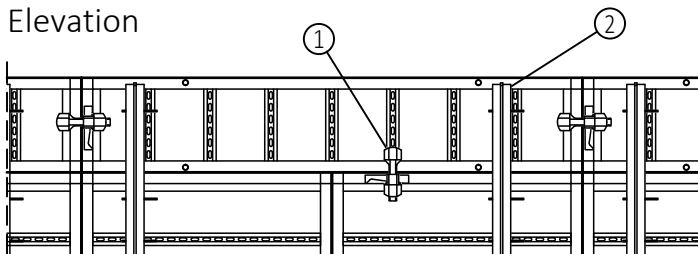

2 alignment clamps and 1 Toplock are attached to 2650 mm wide panel. No tie rods on the side-on panel.

Section

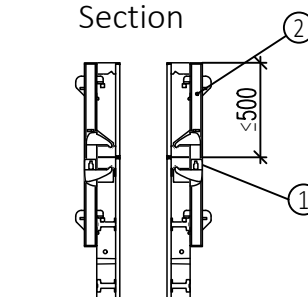

- 1 Toplock
- 2 Alignment clamp Part No. 135309

11.3.4 550-1325 mm extension with Toplock

Elevation

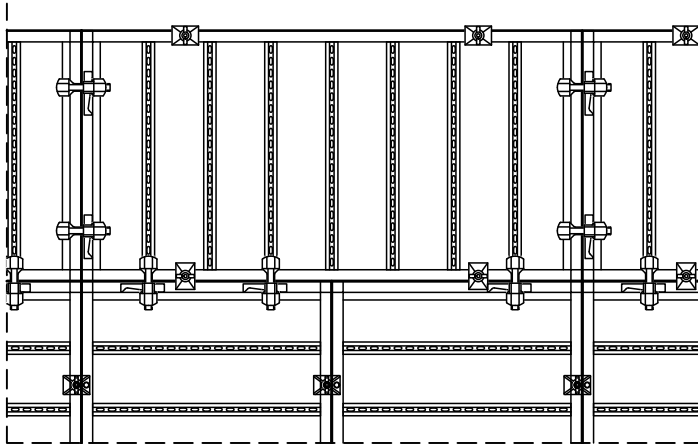

Extension panels have tie rods top and bottom.



- Number of horizontal connections
- Up to 1325 mm panel width 2 Toplock per panel
  - For panel widths of 2650 mm and 3310 mm 3 Toplock per panel

Section

The tie rods can be placed at the top of the panel, see 11.3.2 for extensions up to 500 mm

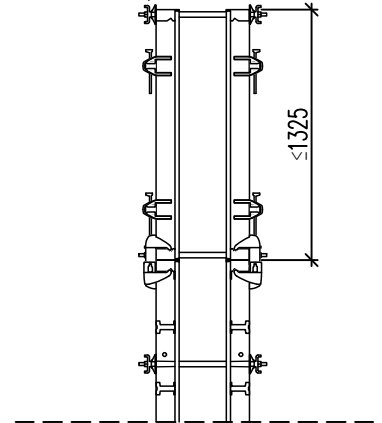

*The combined panels require stiffening with additional alignment clamps to allow them to be moved and lifted together from the assembly area (see below).*

11.3.5 550-1325 mm extensions with alignment clamps and Toplock

e.g. for moving combined panels together

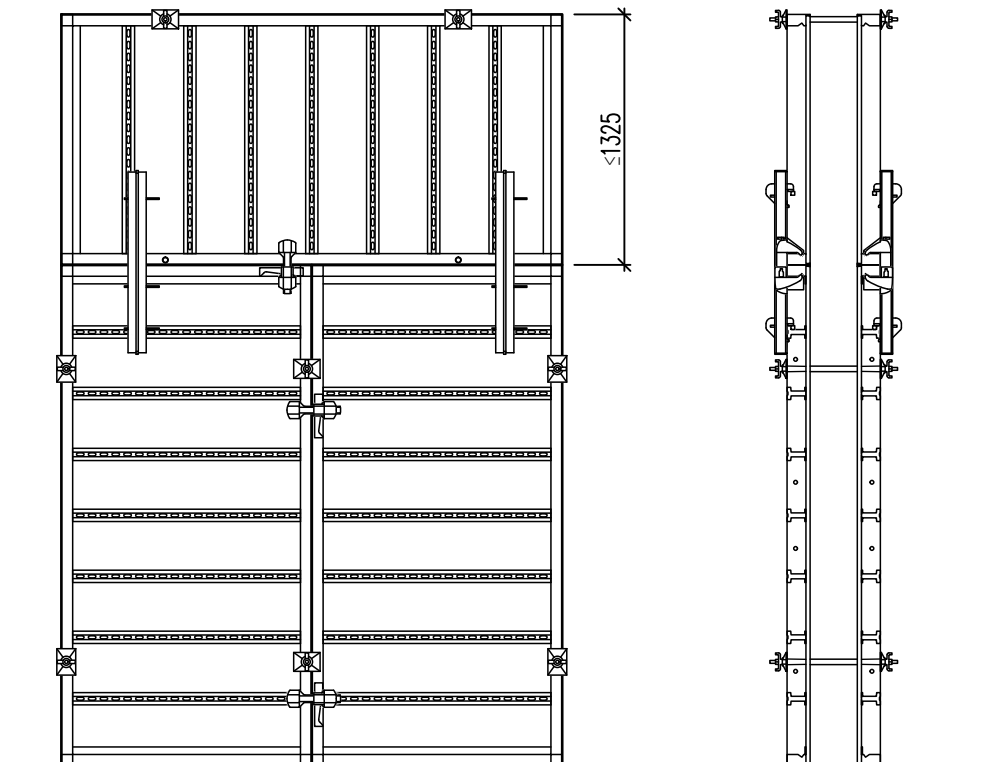

- Side-on panel 2650 mm long: 2 Alignment clamps and 1 Toplock per panel.  
 Side-on panel 3310 mm long: 3 alignment clamps per panel.

11.4 Extensions with large area panels

For information about connections on horizontal and vertical butt joints see "Extensions with end-on panels".

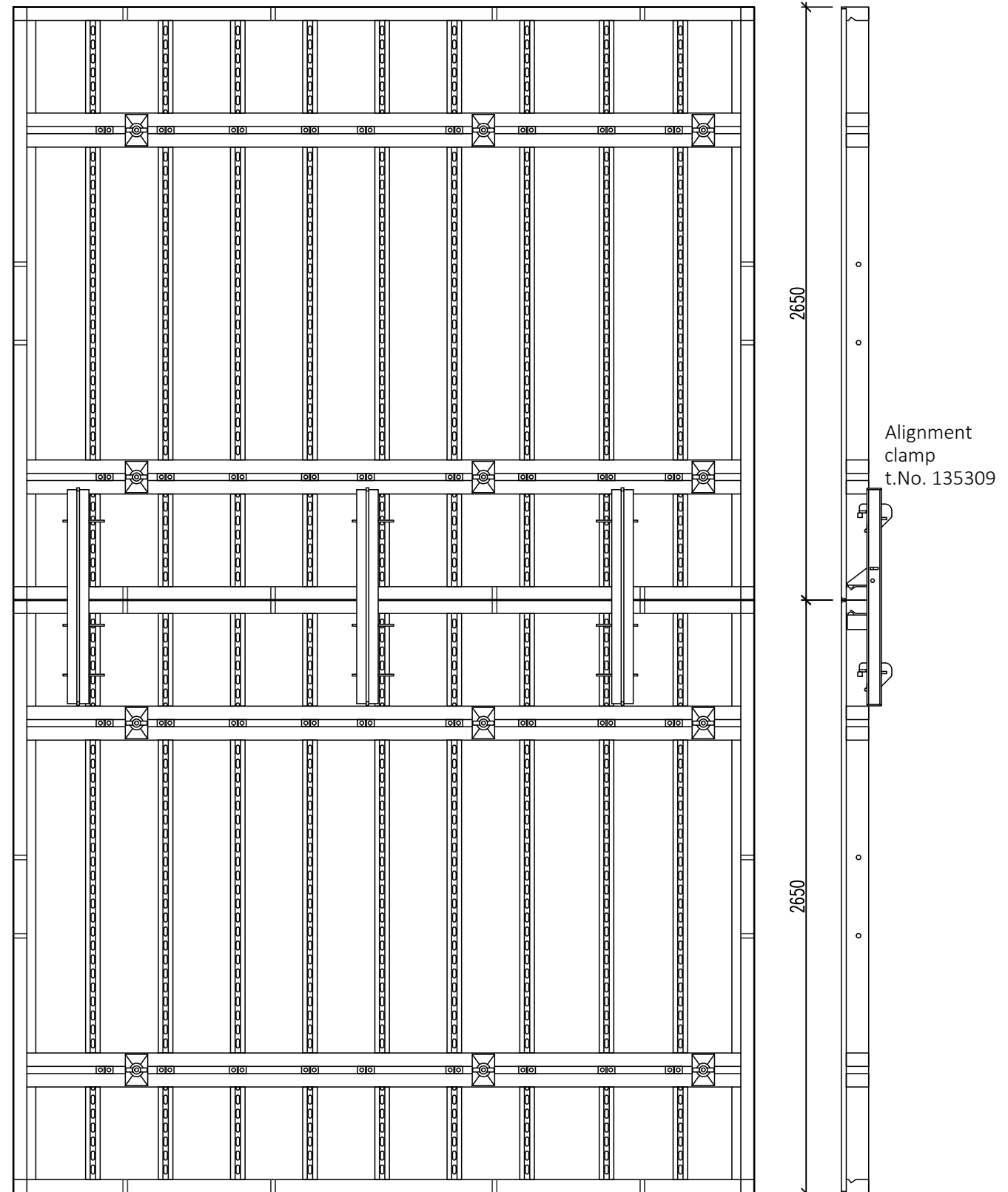

## 12. Special applications of NOEtop

### 12.1 Forming rectangular columns with EC panels ECP

for cross-sections of 100x100 mm to 700x700 mm in increments of 25 mm

Elevation of showing holes through channel of a standard ECP

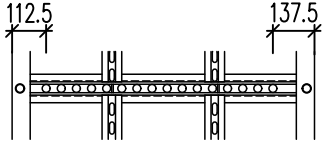

L = 112.5 mm (= centre of 1st hole)  
for sizes 700 - 100 mm at intervals of 50 mm.

ECP turned

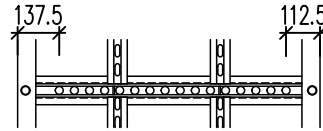

L = 137.5 mm  
for sizes of 675 - 125 mm at intervals of 50 mm.

max. 700x700 mm

min. 100x100 mm

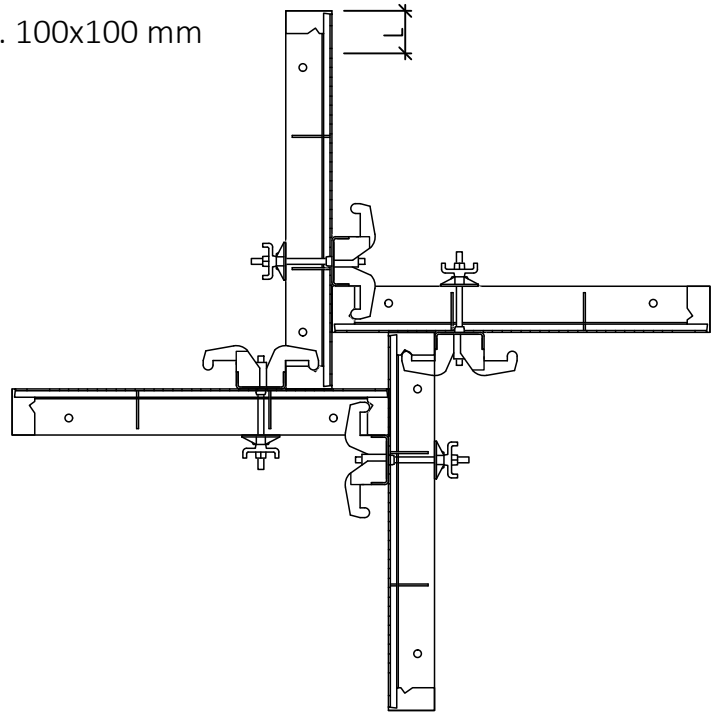
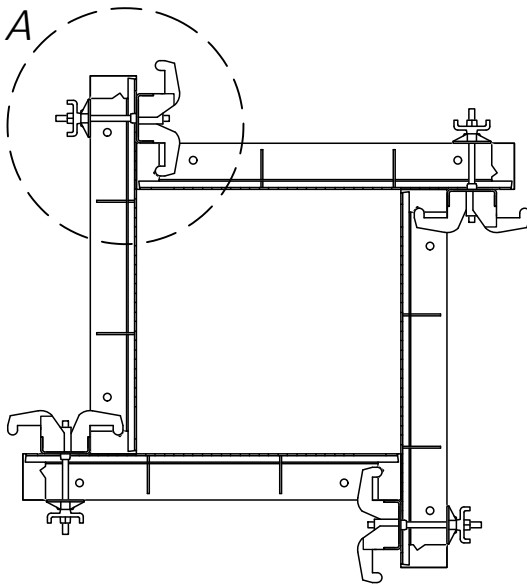

Detail A : Corner connections

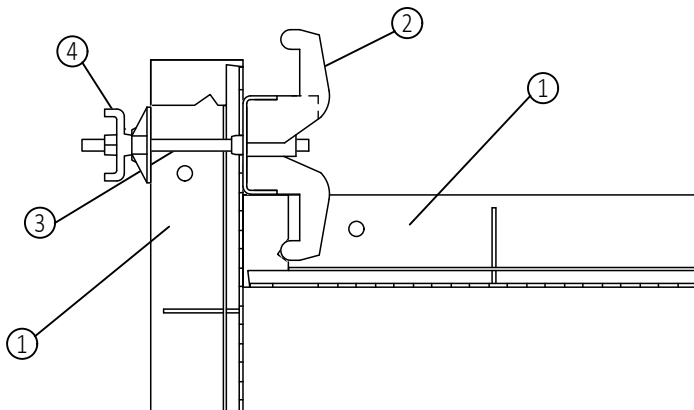

Number of connections

	Panel height	Number
	3310 mm	4
	2650 mm	3
	1325 mm	2
	660 mm	1

- 1 NOEtop ECP 1000
- 2 Multi-claw Part No. 164030
- 3 Tie rod 300 mm Part No. 670300
- 4 Wing nut with swivel plate Part No. 691700

12.2 Overview of the NOEtop stripping corner

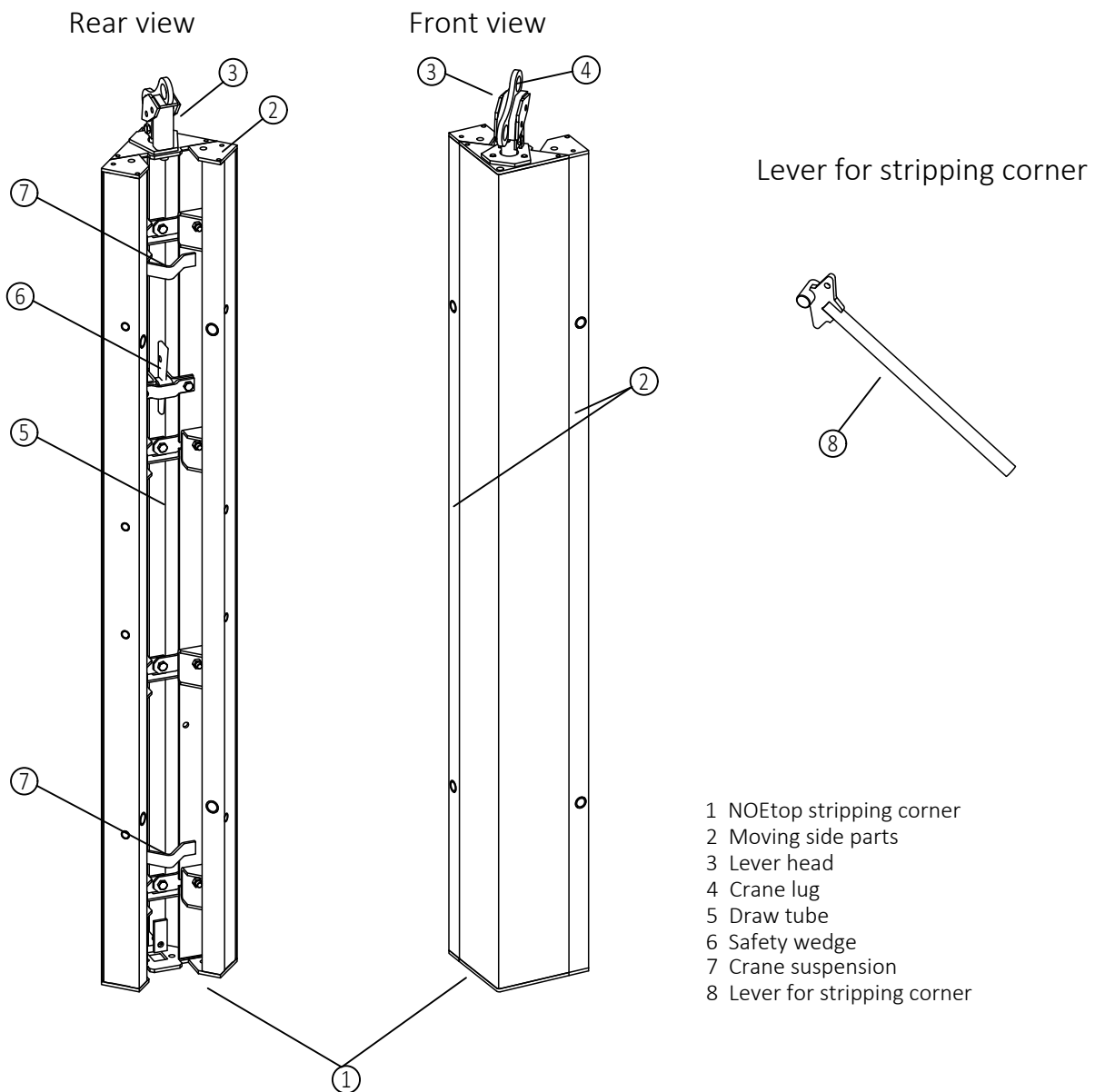

Stripping corners provide stripping clearance of approx. 40 mm.

The permissible concrete pressure is 88 kN/m<sup>2</sup>.

The corner is attached to the formwork with the NOE Toplock or by bolting with M18x160 bolts.



Before using the formwork, read through the assembly and use manual and observe the safety advice given in each chapter at all times!

Everyone who works with the product must receive instruction from a suitably qualified member of the site supervisory staff.



A risk analysis covering all situations on site must be carried out by a responsible person.

Components must be free of defects. Therefore visual inspection and/or testing of each component are essential at all stages of the work!

### 12.2.1 Erecting formwork with stripping corners

- ◆ When erecting formwork for a shaft or similar features, it is recommended that erection starts with the stripping corner at the corner.

When doing this, it is important to ensure that the stripping corner is in the "erection-ready state", i.e. the moving side parts have been fully folded out. This is done by pressing or pulling the crane lug with the side facing the rear face of the formwork upwards. The simplest way of doing this is by suspending the stripping corner from the crane, e.g. when moving it into the installation position.

Set the safety wedge to ensure the sides cannot be unintentionally folded together.

- ◆ Attach the NOEtop panels to one another to suit the plan arrangement then fasten and align them with Toplock V or M18 x 160 bolts. Extend the formwork if necessary. Apply release agent to the front and back formwork faces in accordance with the formwork preparation instructions.
- ◆ Fix reinforcement. Attach the outside face formwork coated with release agent and brace (seal any surplus tie rod holes with plugs).

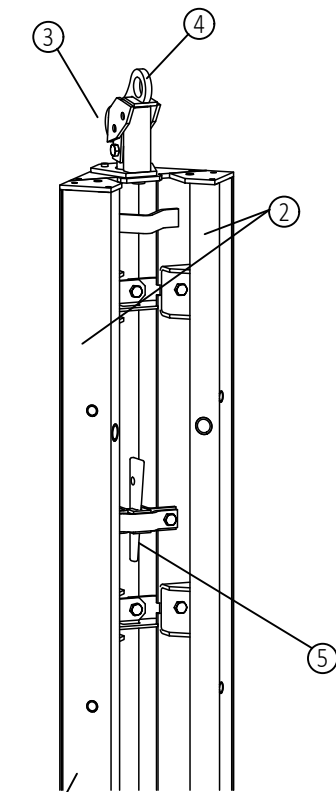

- 1 NOEtop stripping corner
- 2 Moving side parts
- 3 Lever head
- 4 Crane lug
- 5 Safety wedge



Taping the joints between the fixed core and the moving side parts of the stripping corner with self-adhesive tape is recommended to reduce the build up of dirt and the need for cleaning. It also results in a clean, flat concrete surface.

## 12.2.2 Concreting

- ◆ Before concreting, check that the shoes are fully moved out and the safety wedge has been struck home.
- ◆ Check the construction of the NOEtop formwork in accordance with the NOEtop assembly and use instructions.
- ◆ Do not exceed the permissible pressure during concreting (DIN 18218 'Pressure of fresh concrete on vertical formwork'), i.e. pay attention to the rate of rise of the concrete.

- For  $\varnothing 15$  mm tie rods permissible concrete pressure 60 kN/m<sup>2</sup>  
 - For  $\varnothing 20$  mm tie rods permissible concrete pressure 88 kN/m<sup>2</sup>

- ◆ If using internal vibrators refer to DIN 4235 Part 2 "Compaction of concrete by internal vibrators".

## 12.2.3 Stripping the formwork

- ◆ First remove the anchors and strip the external formwork.



Before stripping check:  
 - Minimum stripping time!  
 - Concrete compressive strength!

- ◆ Remove the safety wedges from the stripping corners.
- ◆ Insert the lever into each of the crane lugs of the lever head in turn, press or pull in the direction of the back of the formwork and bring the stripping corners evenly and in incremental stages into the stripping setting.

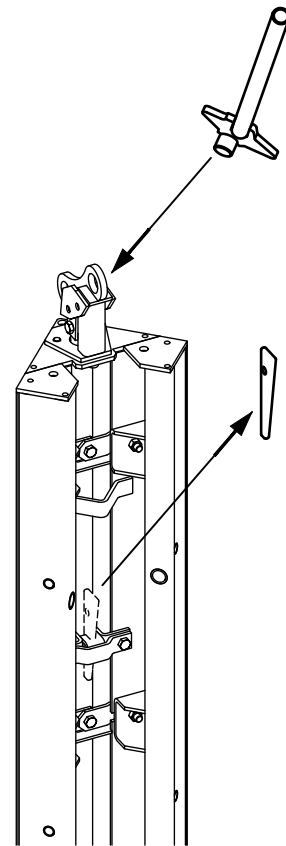
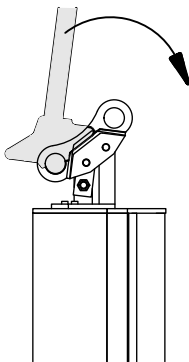

Shown without attached NOEtop panels.



Do not attach the formwork to the crane, do not lift it until the formwork has been completely released from the concrete and the stripping corners have been completely folded together.

**DO NOT USE THE CRANE TO RELEASE THE FORMWORK FROM THE CONCRETE !**  
 Check again that all the tie rods and anchors have been removed before lifting with the crane.

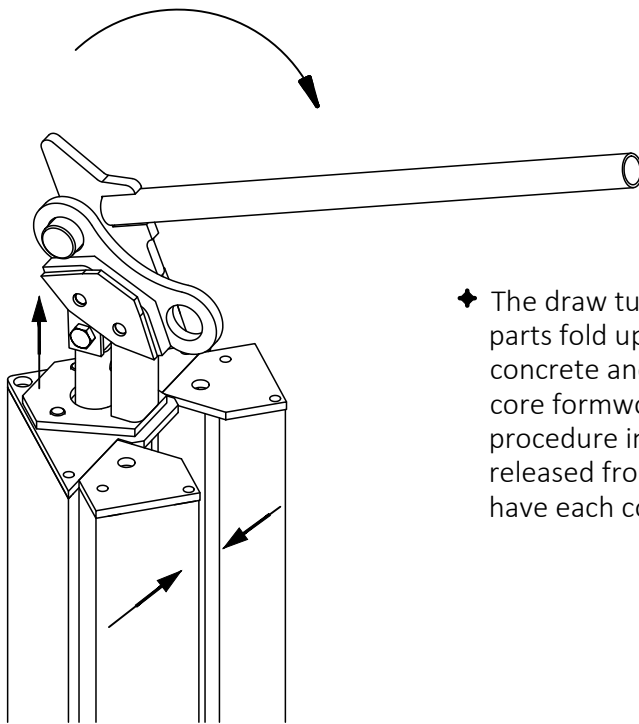

Shown without attached NOEtop panels.

- ◆ The draw tube is moved upwards and the moving side parts fold up together. The formwork releases from the concrete and the external dimensions of the internal core formwork shorten (approx. 40 mm). Repeat this procedure in steps until the formwork is completely released from the concrete and the stripping corners have each completely folded up together.

- ◆ After the formwork is completely released from the concrete, the 4 stripping corners can be attached to the crane's lifting tackle and the complete inner formwork unit moved in a single lift to the next point of use or for cleaning.

Attach the lifting tackle to the upper eye of the crane lug (the one that points towards the front face of the formwork), note that pulling the wrong eye will fold the stripping corners out again.

Ensure that there no loose objects, e.g. the lever, are on or in the formwork.

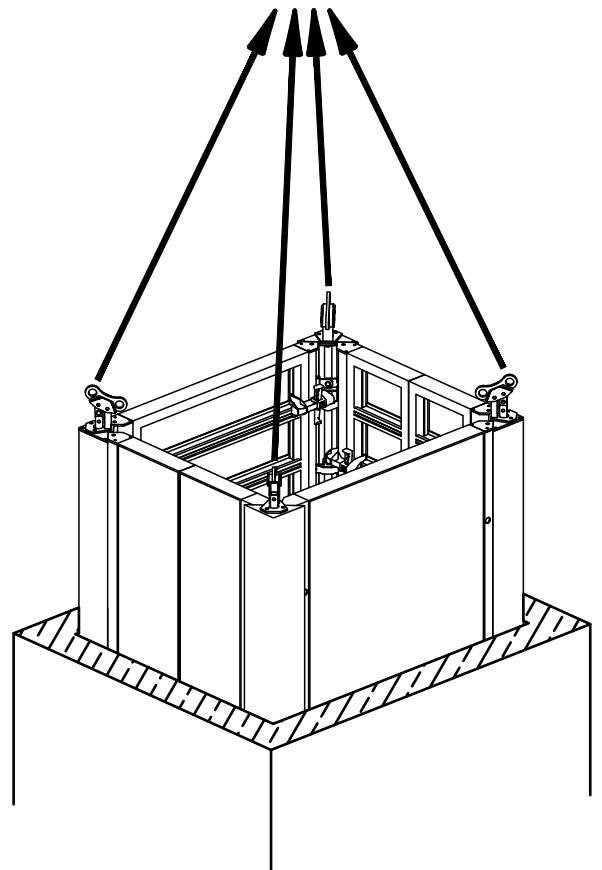

Permissible tensile force applied at the crane lug per stripping corner: 1000 kg  
(Only 3 of the crane lugs can be assumed to be loadbearing at any one time!)

Do not exceed the load capacity of the crane.



12.2.4 Attaching to NOEtop formwork elements

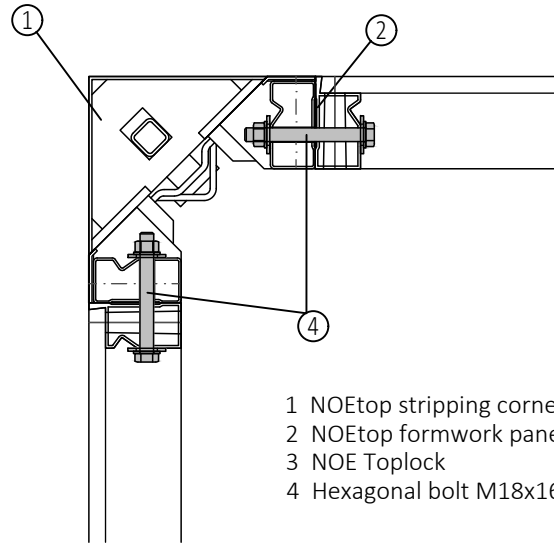
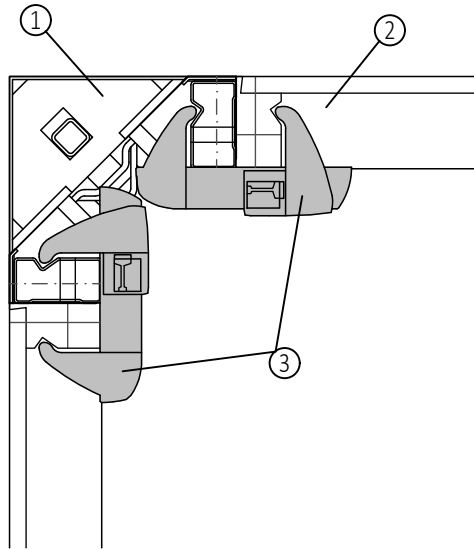

- 1 NOEtop stripping corner
- 2 NOEtop formwork panel
- 3 NOE Toplock
- 4 Hexagonal bolt M18x160

The stripping corner is clamped to the NOEtop frame panel with the NOE Toplock.

Alternatively the stripping corner can be bolted to the NOEtop frame panel. M18 x 160 bolts are used for this.

	Number of Toplock required		Number of threaded connections	
	Panel height	No. Req.	Panel height	No. Req.
	3310 mm	4	3310 mm	4
	3000 mm	4	3000 mm	4
	2650 mm	3	2650 mm	4
	1325 mm	3	1325 mm	2

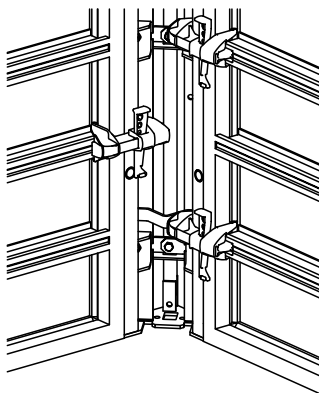

**ATTENTION:**  
NOE Toplock must be attached at staggered heights!

12.2.5 Stripping and erection settings of the stripping corner

The stripping clearance of the stripping corner is approx. 20 mm.

- ◆ Cross-section  
Stripping corner in erection setting

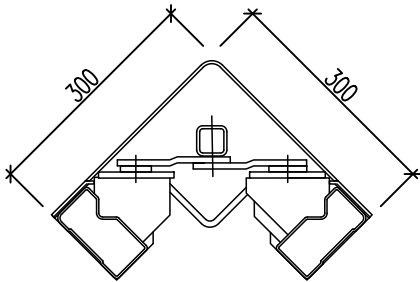

- ◆ Cross-section  
Stripping corner in stripping setting

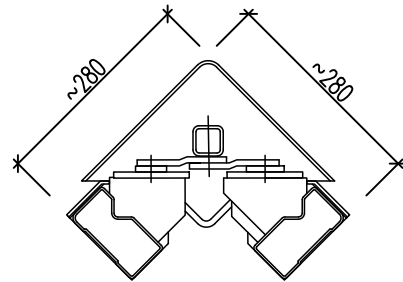

Example of formwork in erection setting

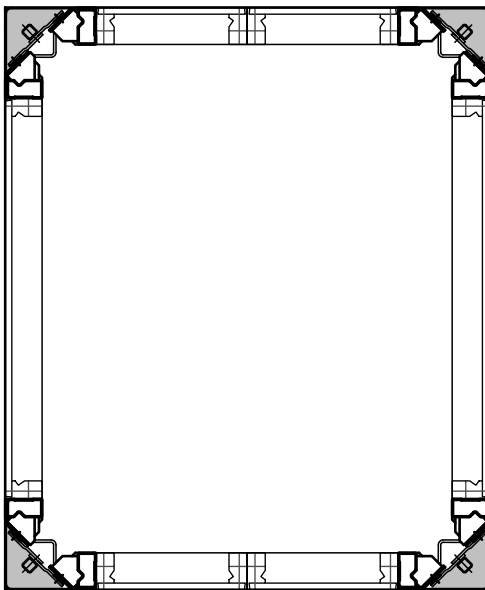

Example of formwork in stripping setting

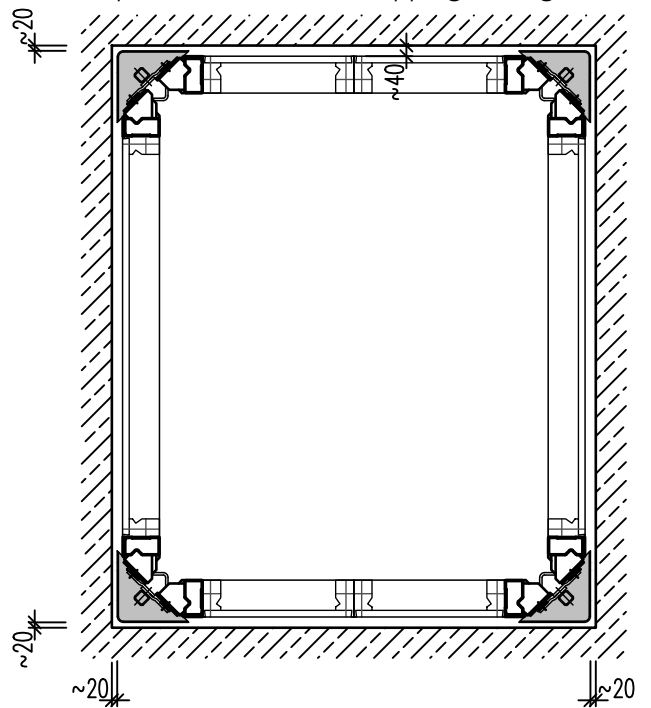

12.2.6 Extending stripping corners

First erect the lower formwork elements in the specified plan shape as described above. Then the lever head must be removed to allow the stripping corners to be extended. The lever head is fitted with a bayonet connector and is secured with a bolt.

- ◆ First release and take out the bolt (it will be needed later to connect the draw tubes)

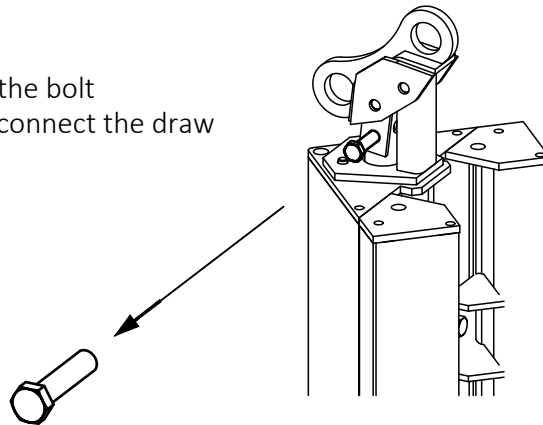

- ◆ Turn the head approximately 30° anticlockwise to release it. Then the locking pin heads can be guided out of the large holes in the plate and the head removed.

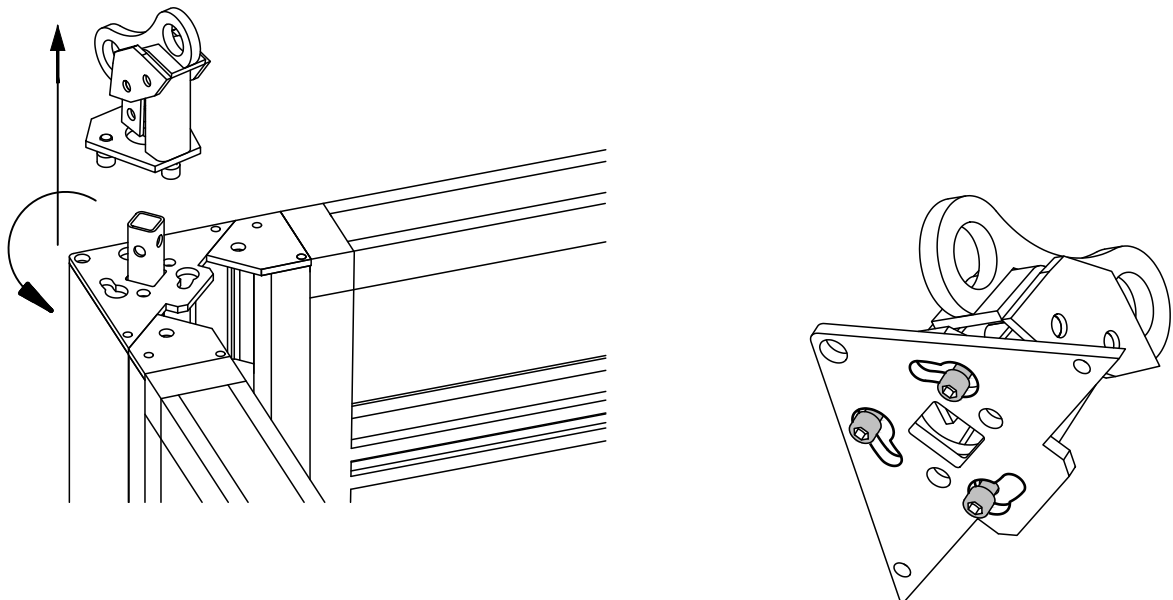

View from below:  
Cover plate and lever head with bayonet lock ("bayonet lock")

- ◆ Installing the extension element. The draw tube on the lower stripping corner is threaded through rectangular opening in the base plate and then connected and secured with a bolt.

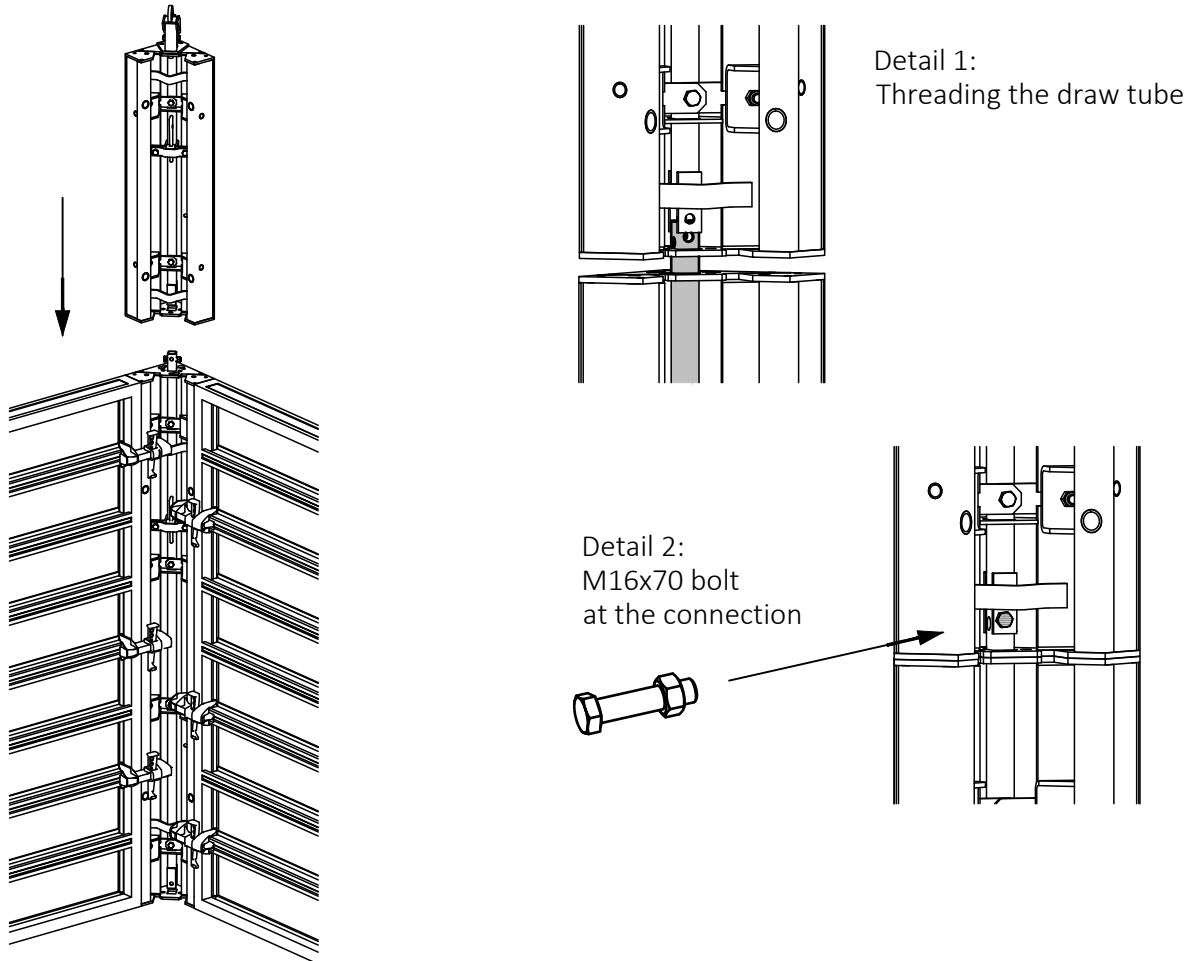

- ◆ Connect the extension element of the NOEtop frame panel to the stripping corner and secure them together with NOE Toplock.



If the stripping corners are to be extended in advance of installation, e.g. formwork preassembled on its side, then the roughly butted base and cover plates of the corners must be bolted together with 2 M16x40 bolts !  
The corners must be in the erection setting in order to be able to remove the lever head.

## 12.2.7 Crane transport

- ◆ The corner can be suspended from the 2 integrated crane bows for transporting the stripping corner horizontally, e.g. for loading or unloading.

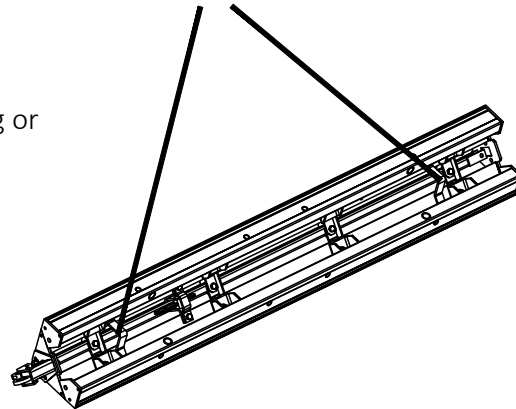

- ◆ The crane hooks can be engaged into the crane lugs of the lever head for transporting vertically. This also results in the stripping corners being brought into the erection setting simultaneously. They each still have to be secured with the wedge.

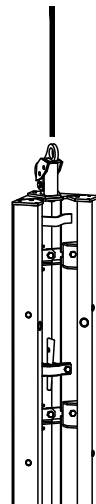

- ◆ After the formwork has been released from the concrete, the NOEtop stripping corners are suspended from the crane lugs and the complete formwork moved in a single lift.

**Attention:**

Suspend the formwork from the crane lugs pointing to the formwork lining side. Otherwise the formwork will be separated again.

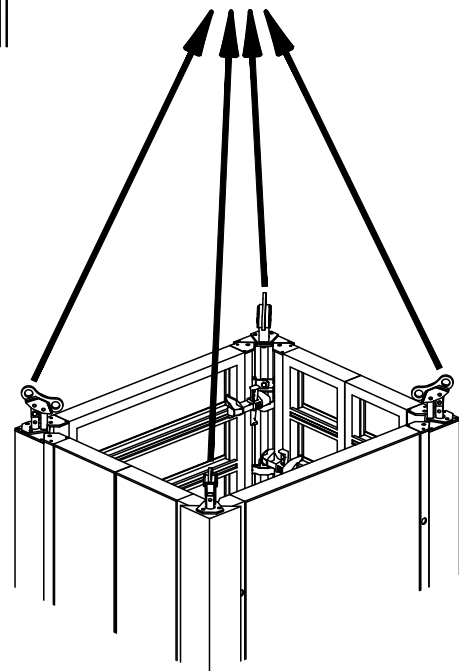

12.3 Use as foundation formwork

Pad foundation with side-on panels

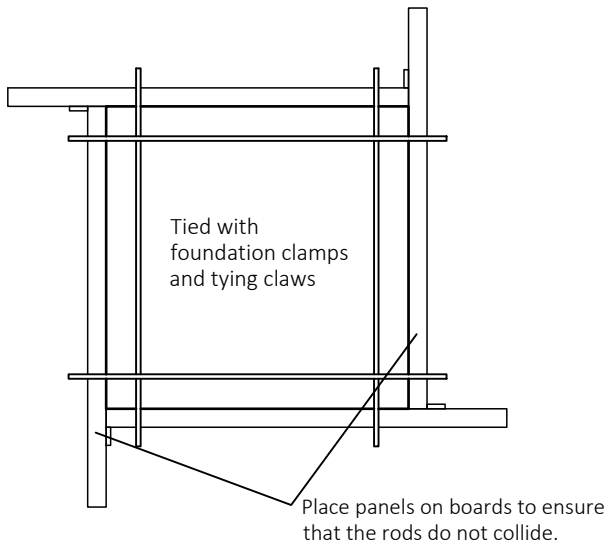

Detail of tie rod at top

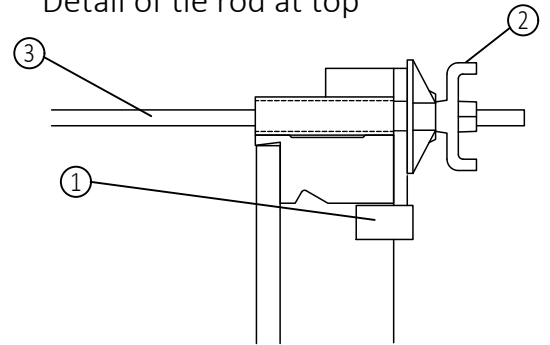

Tying can also be done using multi-claws.

Detail with tie at bottom  
Tie with foundation clamp

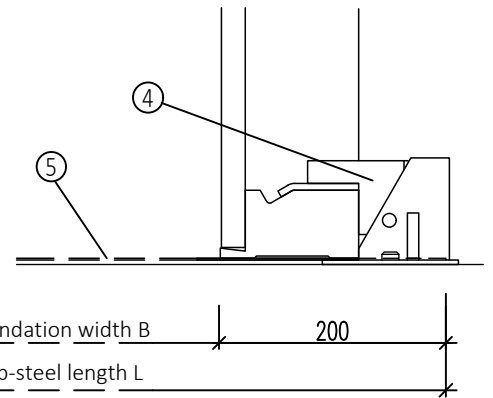

Example of panel corner connection  
Butt corner joint with Toplock X

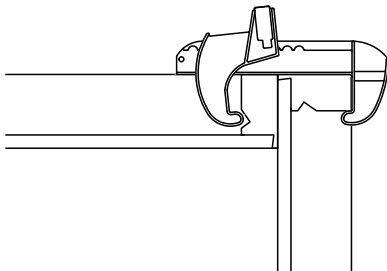

Attach 3 locks at a height of 1325 mm.

Foundation formwork to be supported push pull safe on site

Strip foundations with side-on panels

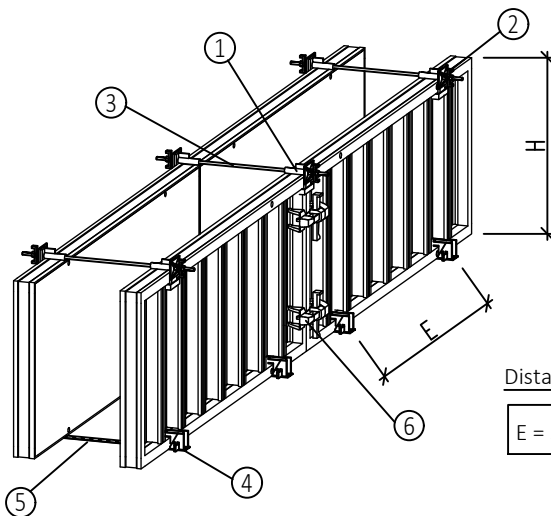

Length of strip-steel

$L = B + 400 \text{ [mm]}$

Distance between foundation clamps

$E = 36 / (25 \times H^2) \text{ [m]}$

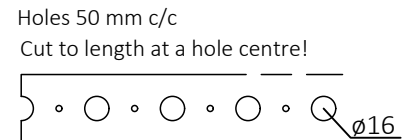

Permissible tension force 12 kN.

for H = 0.8 m E = 2.25 m  
for H = 1.0 m E = 1.45 m  
for H = 0.85 m E = 1.13 m  
Min. 2 clamps per panel.

- 1 Tying claw Part No. 137500
- 2 Wing nut with plate Part No. 691700
- 3 Tie rod  $\varnothing 15$  mm Part No. 67.....
- 4 Foundation clamp Part No. 137297
- 5 Strip-steel stressing device Part No. 108031
- 6 Toplock

### 13. Special applications of NOEtop with integral bracing

#### 13.1 Single-sided formwork

Concreting height up to 3.31 m

(For concreting heights ≤ 2.40 m see 13.1.2)

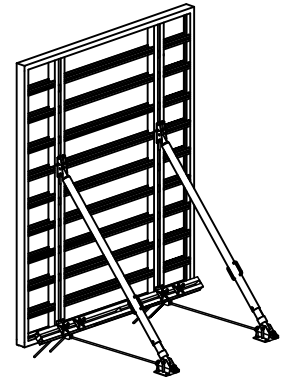

*This application calls for NOEtop panels with integral bracing (2650x2650 mm or 3310x2650 mm). Alternatively standard panels with NOEtop attachable bracing may be used, as shown in Version II.*

*The necessary supports are attached directly to the integral bracing of the NOEtop panel or the NOEtop bracing.*

*The anchor rods must be designed and put in position before the floor slab or foundation is cast. 2 anchor bolts are required for each stabilizer.*

When concreting walls with one formed face the force due to the concrete pressure must be transferred by the formwork and suitable stabilizers and anchors to the supporting ground.



To ensure the erected formwork element is structurally stable, it must be able to resist tension forces or be secured by other means (e.g. ballast placed against the wall, erected against a wall or slope).

Tensile-resistant guy

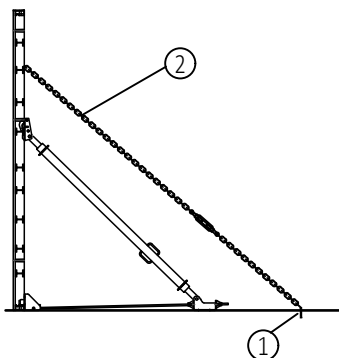

Anchored tying support

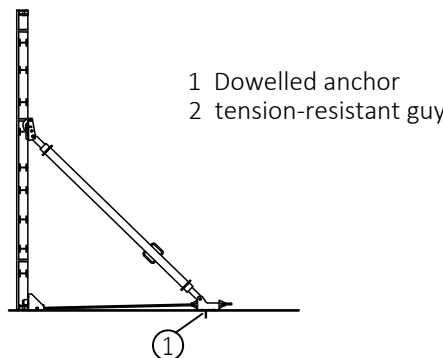

Lean against a wall or slope

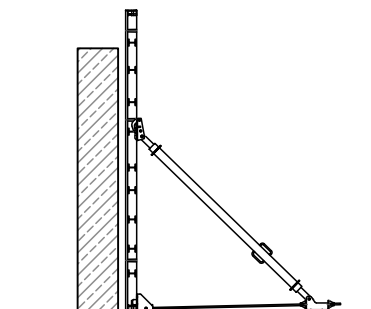

# NOEtop formwork



## 13.1.1 Range of application

### Structural system

Version I: NOEtop panel with integral bracing

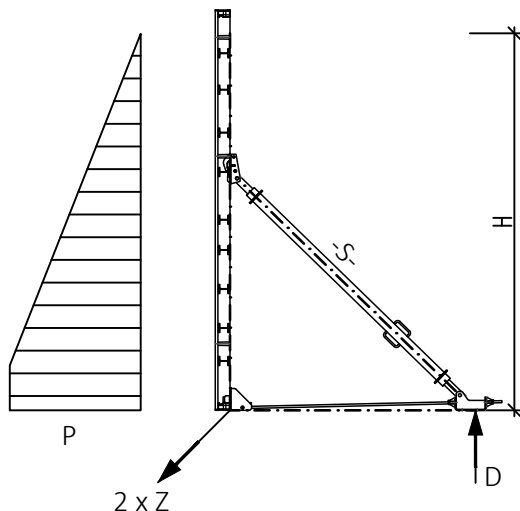

Version II: NOEtop bracing

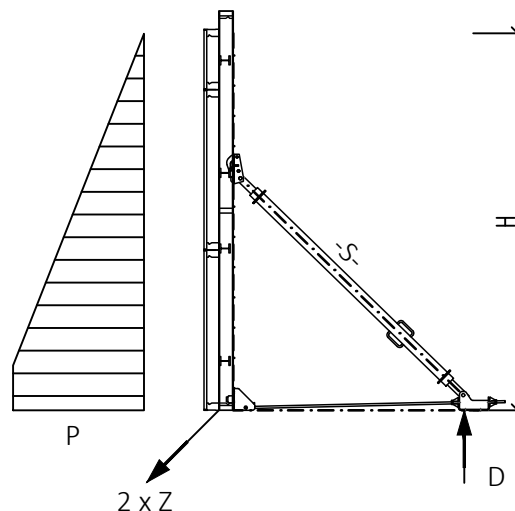

Design the permissible concrete pressure and anchor force to suit the concreting height!

The anchors must be installed before the floor slab or foundation is concreted. The load capacity of any supporting building component and the component which carries the anchor force and the force from the concrete pressure must be designed and checked by the local site supervisory staff!

Concreting height [m]	For effective width of 1325 mm (NOEtop with integral bracing)				For effective width of 1000 mm			
	Perm. conc. press. [KN/m <sup>2</sup> ]	Force Z per anchor [KN]	Comp. force D [KN]	Strut S [KN]	Perm. conc. press. [KN/m <sup>2</sup> ]	Force Z per anchor [KN]	Comp. force D [KN]	Strut S [KN]
2,25	Hydrost.	59,5	31,5	44,5	Hydrost.	45,0	24,0	34,0
2,50	Hydrost.	73,5	43,5	61,0	Hydrost.	55,5	33,0	46,0
2,65	Hydrost.	82,5	51,5	73,0	Hydrost.	62,5	39,0	55,0
2,75	60	87,5	57,5	81,0	Hydrost.	67,0	43,5	61,5
2,85	50	87,0	62,5	88,0	Hydrost.	72,0	48,5	68,5
3,00	40	82,5	67,0	95,0	60	76,5	56,0	79,0
3,15	35	80,5	71,5	101	50	76,0	62,0	88,0
3,30	30	76,0	73,5	104,5	40	71,0	64,5	91,5

Values for other effective widths and concrete pressures on request.



13.1.2 Assembly of one-sided panel

Version I: NOEtop panel with integral bracing

Version II: NOEtop bracing

Section

- 1 NOEtop panel with integr. bracing
- 2 NOEtop bracing 3300 mm  
Part No. 541025 or  
NOEtop bracing 2640 mm  
Part No. 541024 for low heights
- 3 HHB with handle Part No. 319338
- 4 Head support Part No. 541036
- 5 Strut Part No. 541044
- 6 Tying support Part No. 541052
- 7 Bottom support Part No. 541041
- 8 Tie rod Part No. 672000
- 9 Sprint nut Part No. 680580
- 10 Tie with bracing
- 11 Lost anchorr
- 12 Bolt Part No. 541053
- 13 Spring pin Part No. 913305

Platform brackets not shown.  
They must be attached to the  
panels in accordance with the  
requirements.

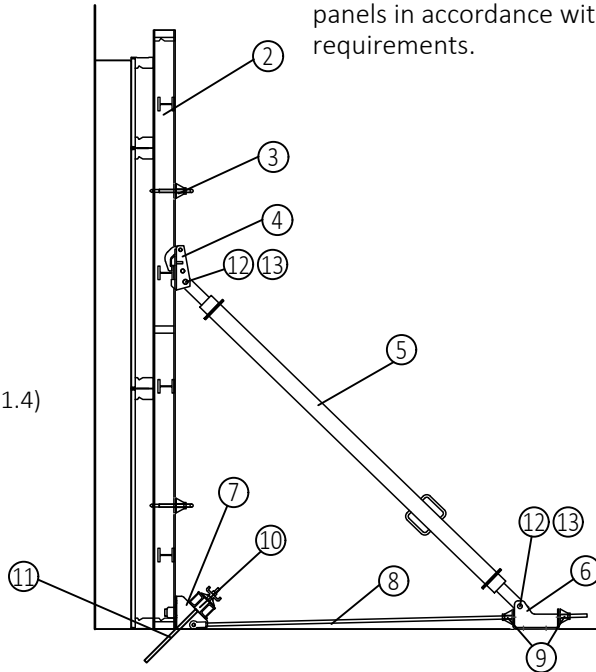
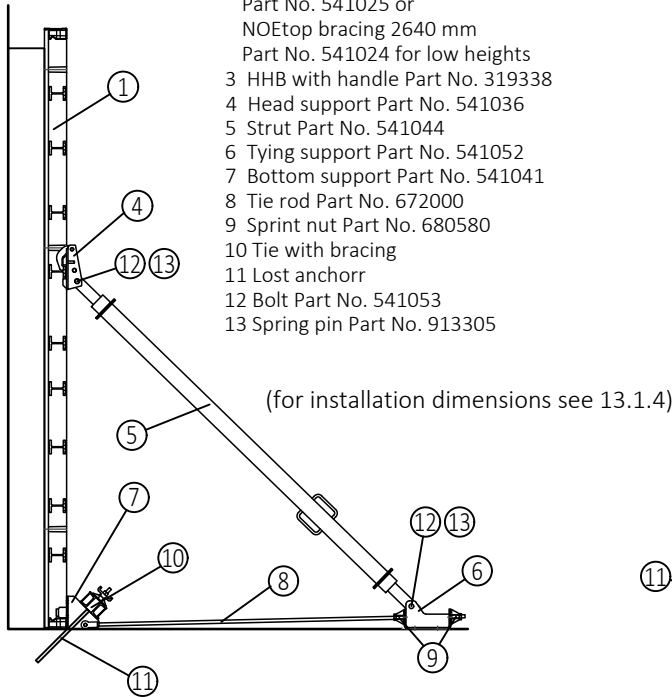

Elevation (without strut and tying support)

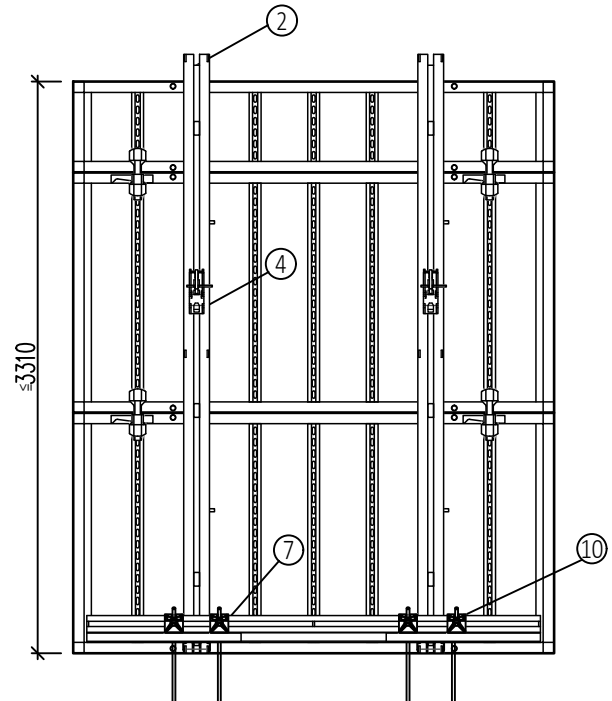
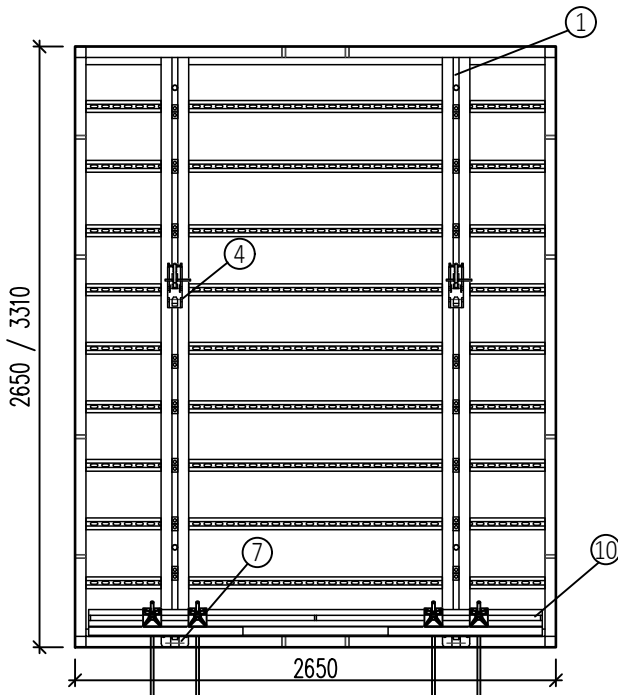

Plan

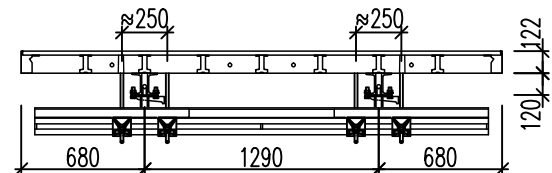
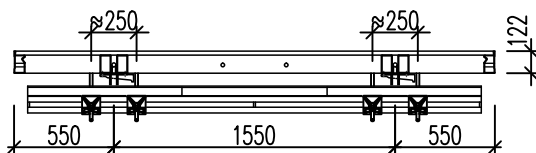

# NOEtop formwork



## Dimensions for assembly

- ◆ Concreting height up to 2400 mm

### Version I: NOEtop-panel with integral bracing Section

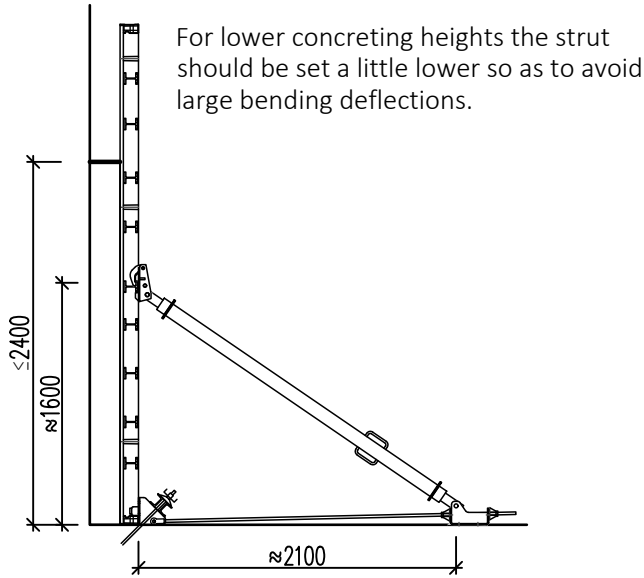

### Version II: NOEtop bracing

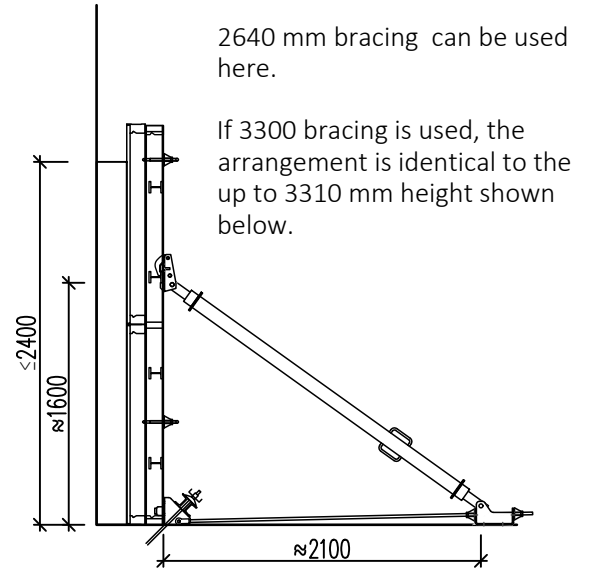

☞ As the tying support is set further back the longer tie rod Part No. 672250 must be used.

- ◆ Concreting height 2410 - 3310 mm

### Version I: NOEtop panel with integral Bracing Section

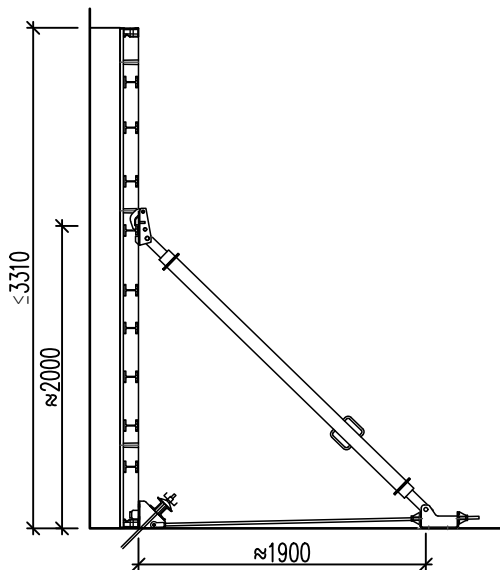

### Version II: NOEtop bracing

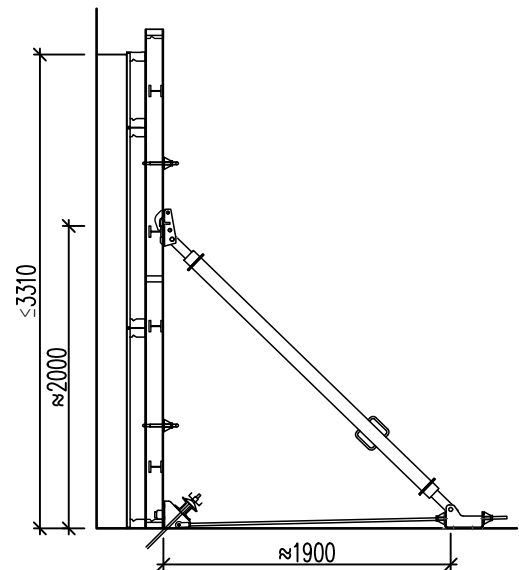

13.1.3 Details of one-sided panel

Detail of head support attachment

Version I: NOEtop panel with integral bracing

Version II: NOEtop bracing

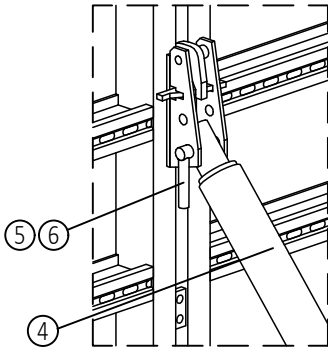

Attach the head support into the distance piece of the integral bracing or the NOEtop bracing and drive in the wedge.

Fix the strut with bolts and secure the bolts with spring pins.

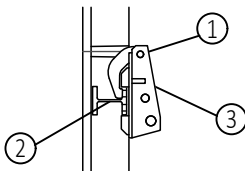
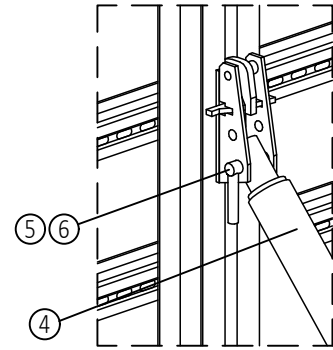

- 1 Head support Part No. 541036
- 2 Distance piece in integral bracing or NOEtop bracing
- 3 Wedge
- 4 Strut Part No. 541044
- 5 Bolt Part No. 541053
- 6 Spring pin Part No. 913305

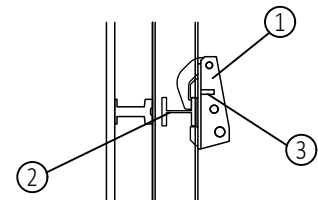

Detail of bottom support attachment

Version I: NOEtop panel with integral bracing

Version II: NOEtop bracing

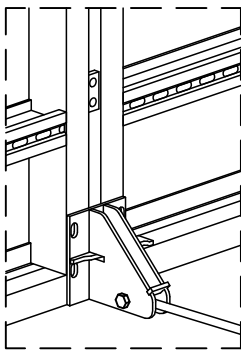

Fasten the screw base with bolt M16x70 into the bottom support.

Fix the bottom support in place by driving in the wedge.  
In the case of using NOEtop bracing with distance 40 mm, attach the bottom support with 2xM16x50 (bore holes are in bracings).

Screw in the tie rod in the screw base until it meets the stop.

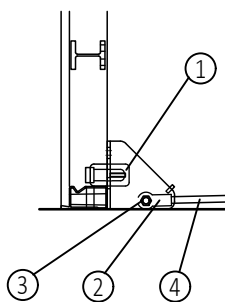
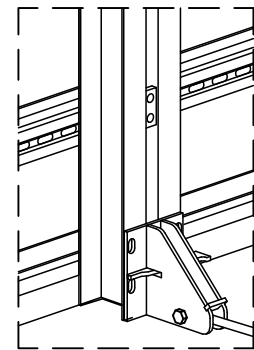

- 1 Bottom support Part No. 541041
- 2 Screw base Part No. 117240
- 3 Bolt M16x70
- 4 Tie rod 2.00 m Part No. 672000



If the bottom support is not firmly seated on the base, it must be supported in such a way that transmits force (e.g. with hardwood).

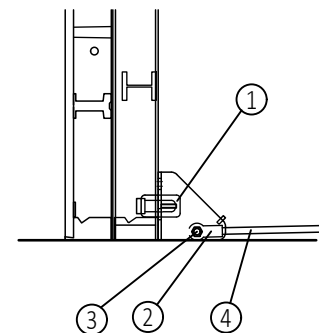

## Detail of tying support

Screw sprint on to tie rod, push tying support on to tie rod and lock with second sprint.  
 Connect the strut to the tying support using bolts and secure the bolts with spring pins.  
 The bolts and spring pins are not part of the tying support.

- 1 Tying support Part No. 541052
- 2 Sprint nut Part No. 680580
- 3 Strut Part No. 541044
- 4 Bolt Part No. 541053
- 5 Spring pin Part No. 913305

The tying support must not be anchored to the existing concrete!

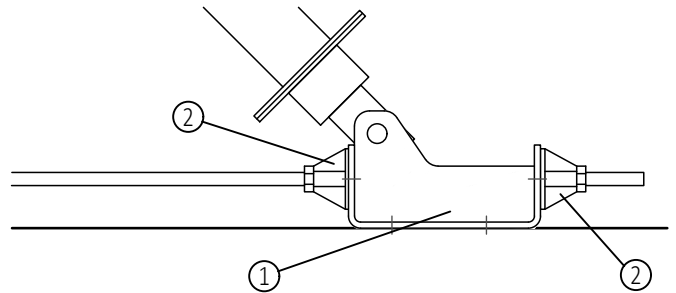
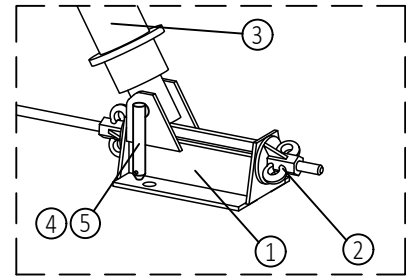

## Detail of fastening of NOEtop bracing to system formwork e.g. NOEtop

### Section

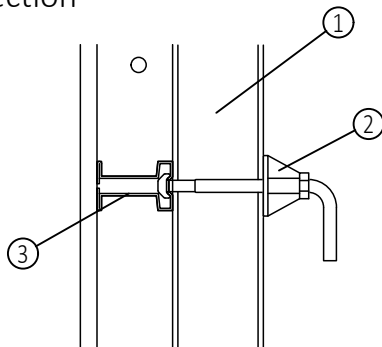

The NOEtop bracing is fastened in place with the hammer-head bolt with handle in the elongated hole in the hat profile .

- 1 NOEtop bracing
- 2 Hammer-head bolt with handle Part No. 319338
- 3 Hat profile in the panel

### Plan

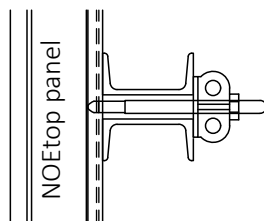

Connect the NOEtop bracing in at least 2 places to the panel.

## Use of local bracing

Tying the bottom support cannot be done using bracing 2.50 m (Part No. 543030) therefore compensation channels (Part No. 135109) must be used.

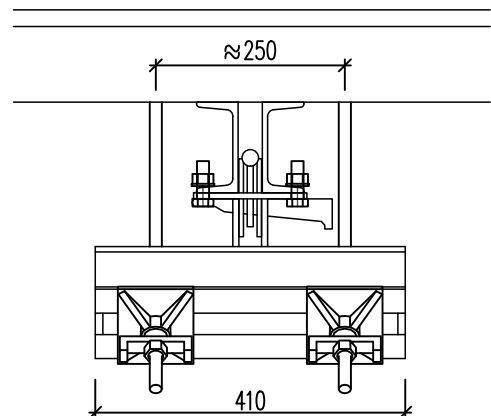

13.1.4 Anchor installation

Version I: NOEtop-panel with integral bracing

Version II: NOEtop bracing

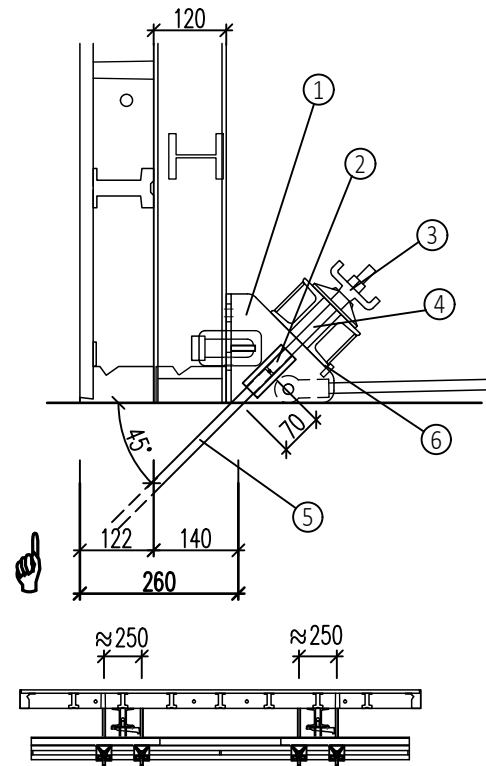
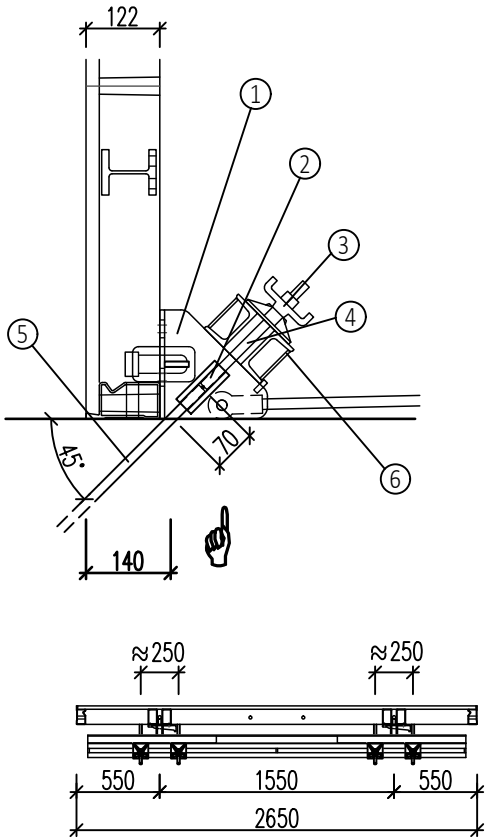

Plan

- 1 Bottom support Part No. 541041
- 2 Coupler nut Part No. 684000
- 3 Wing nut with plate Part No. 691700
- 4 Tie rod 30 cm Part No. 670300
- 5 Lost anchor  $\varnothing 15$
- 6 Bracing Part No. 543030

The permissible tension loads given in this section, the concrete compressive strength must be at least 25 MN/m<sup>2</sup>.

For an overview of lost anchors see 16.16.3

Install lost anchors at 45° at a distance of 140 mm (NOEtop panel) or 260 mm (NOEtop bracing) from the edge of the wall.

Where coupler nuts are used the anchors must project a min. 70 mm.

The design of the panels, connections and stabilizers is carried out by the user, unless otherwise indicated here.

Modification of Version II:

The anchors are installed as for Version I, but Version II is used instead. The difference can be compensated for by inserting hardwood or similar under the bracing and bottom support to transfer the forces.

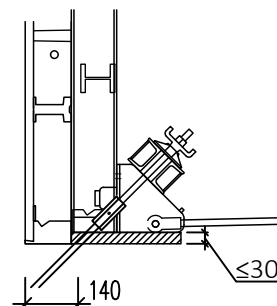

13.2 Forming vertically tapering walls

Large area panels with dimensions 2650x2650 mm, 2650x3310 mm, 5300x2650 mm and the MFP 1325x2650 mm can be used with vertical bracing.

- 1 Swivel plate with wing nut  
Part No. 691700
- 2 Hardwood wedge with hole
- 3 Lifting restraint (designed on site)
- 4 Tying plate Part No. 164040

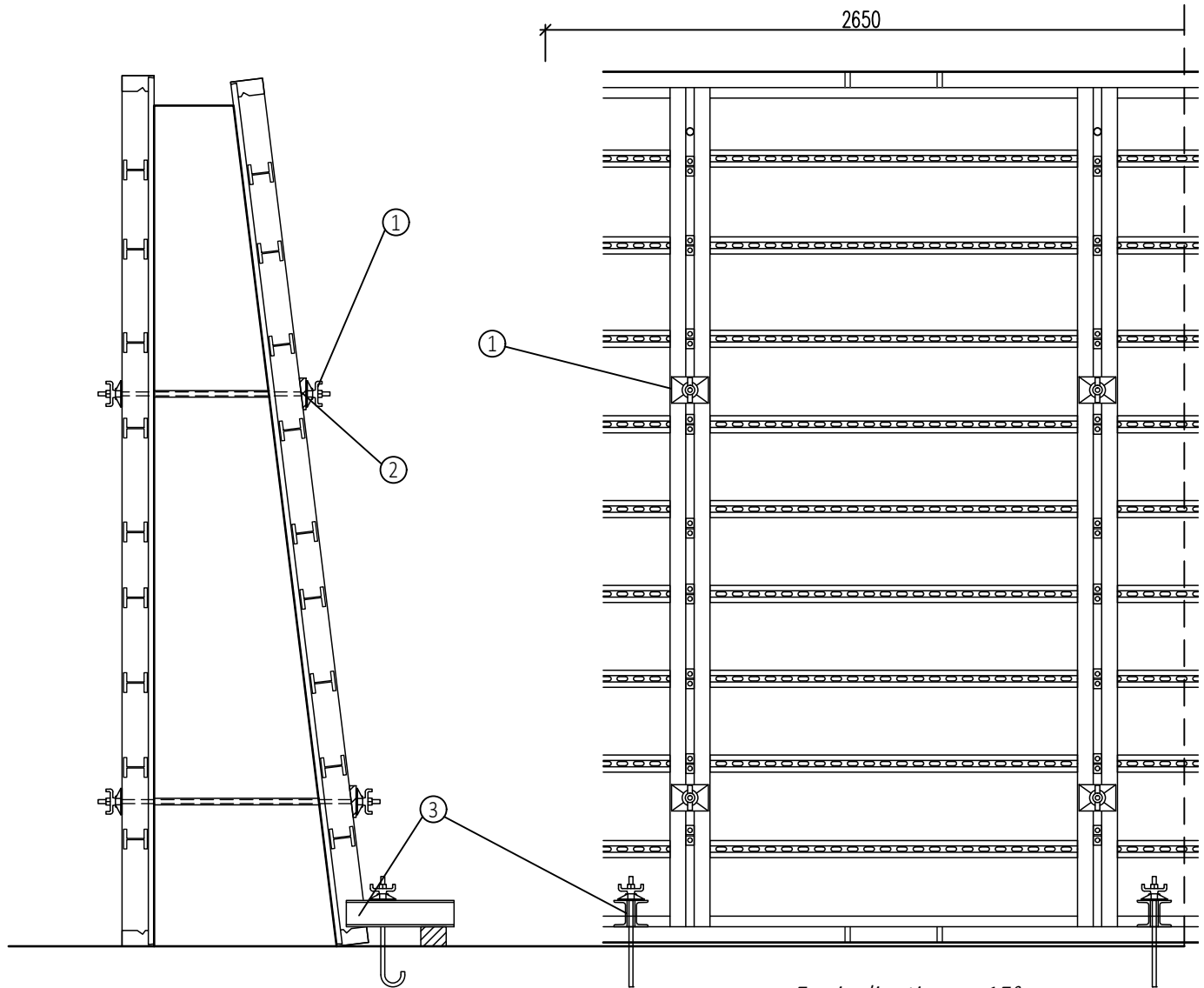

 A hardwood wedge can be used to compensate for an angle of slope of up to 15°. Alternatively you may use a tying plate Part No. 164040.

Structural calculations are required if the tying positions are modified on site.

The tie rods can be installed at right angles to the panel on one side so that the plastic tube only needs to be cut at a skew on one side.

For inclinations > 15°:

Tie with tying plate  
Part No. 164040

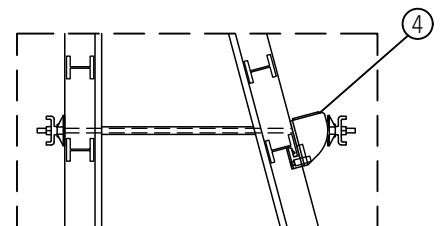

13.3 Formwork with acute-angled corners

Large area panels with dimensions 2650x2650 mm, 2650x3310 mm, 5300x2650 mm and the MFP 1325x2650 mm can be used, with horizontal bracing.

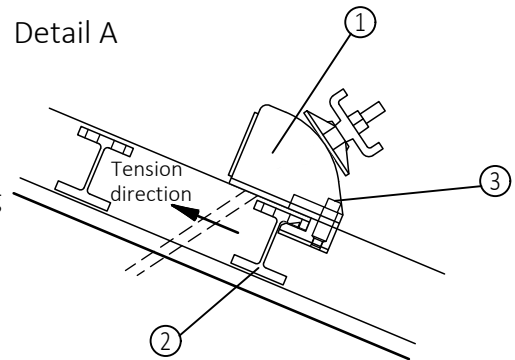
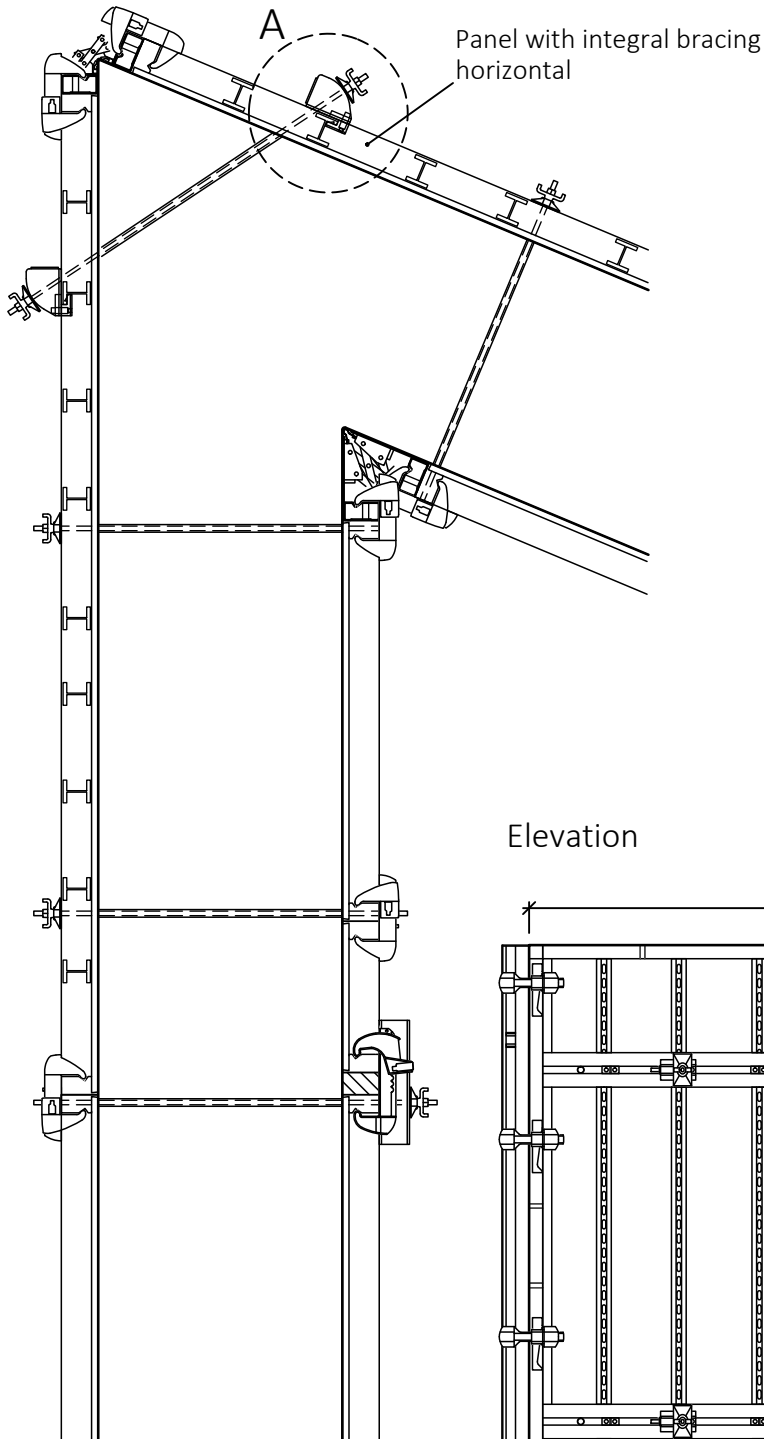

Put the tying plate into the distance piece of the integral bracing and engage it. Take note of the direction of tension.  
Press locking button to release and disengage plate.

- 1 Tying plate Part No. 164040
- 2 Distance piece
- 3 Locking button

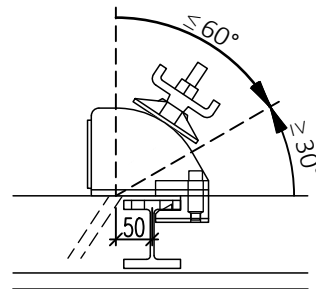

Elevation

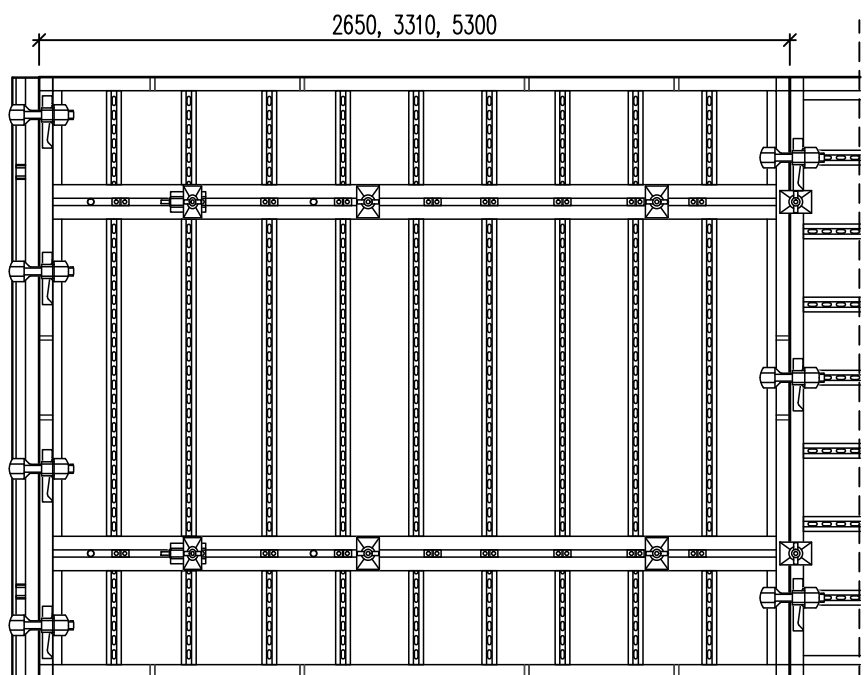

13.4 Use with special tie rod spacing requirements

Tie rod spacing can be varied near the integral bracing

2650 mm (large area panel 3310x2650) e.g. with specified tie rod spacing A

1325 mm + e.g. 500 mm (MFP side-on) e.g. with a specified tie rod height H (top tie rods are on top of the panel)

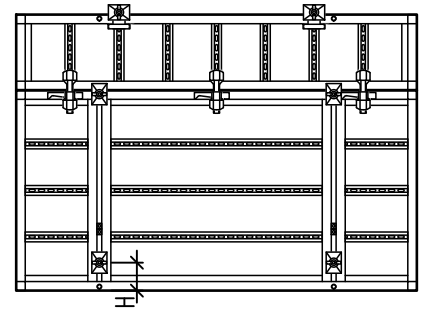
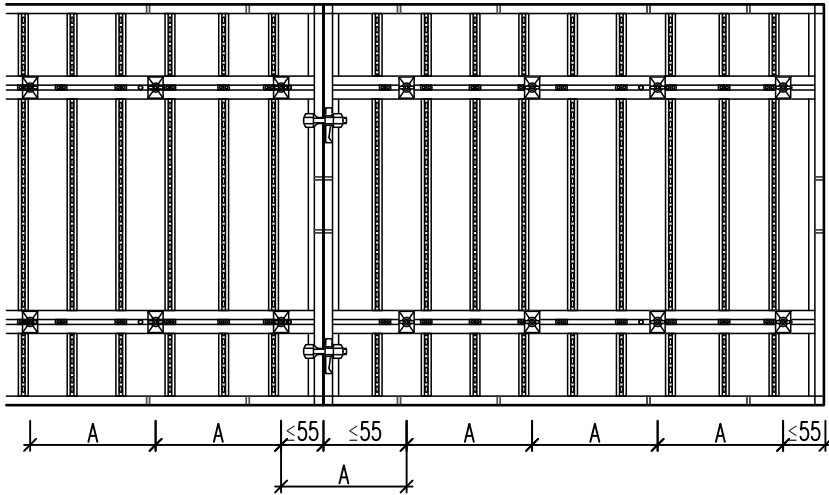

Panels with integral bracing and normal panels on opposite sides

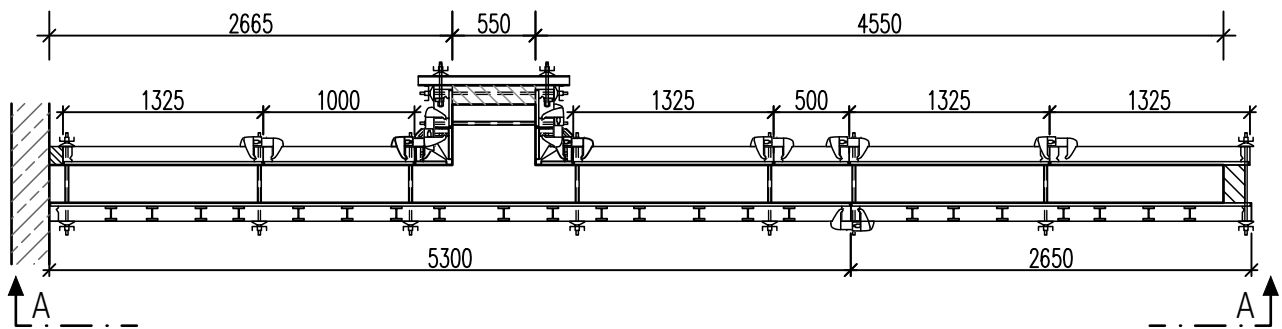

Elevation A-A

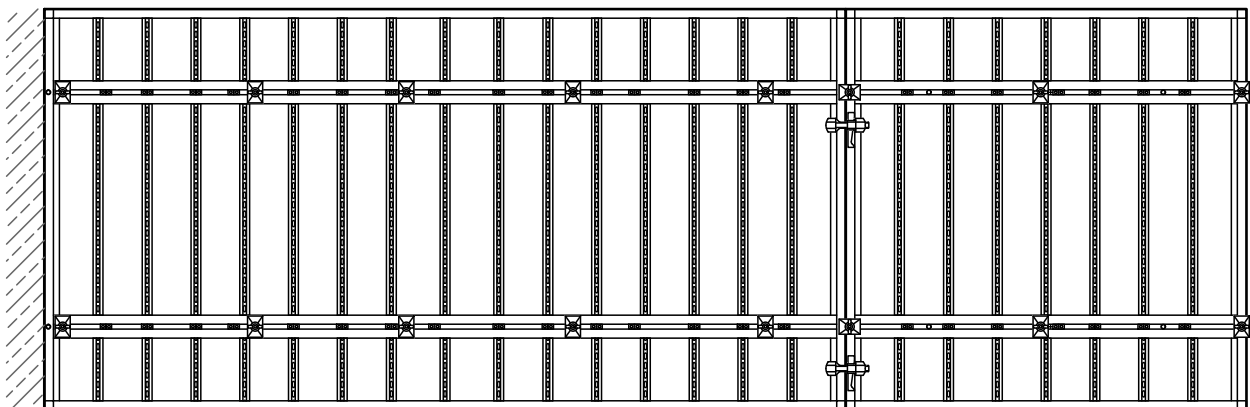



# NOEtop formwork

## 14. NOEtop Alu panels

Can be combined with NOEtop elements. Detailed solutions for products such as NOEtop, in corners Alu EC panels and internal corner are used, for other special solutions for NOEtop Alu can be found on the following pages.

⇒ Refer to 15.1.4 for transporting formwork

Permissible. concrete pressure 60 kN/m<sup>2</sup> in acc. with DIN 18218 !  
(Tie rods ø15 mm)

### 14.1 Panel dimensions NOEtop Alu

Panel height 2650 mm

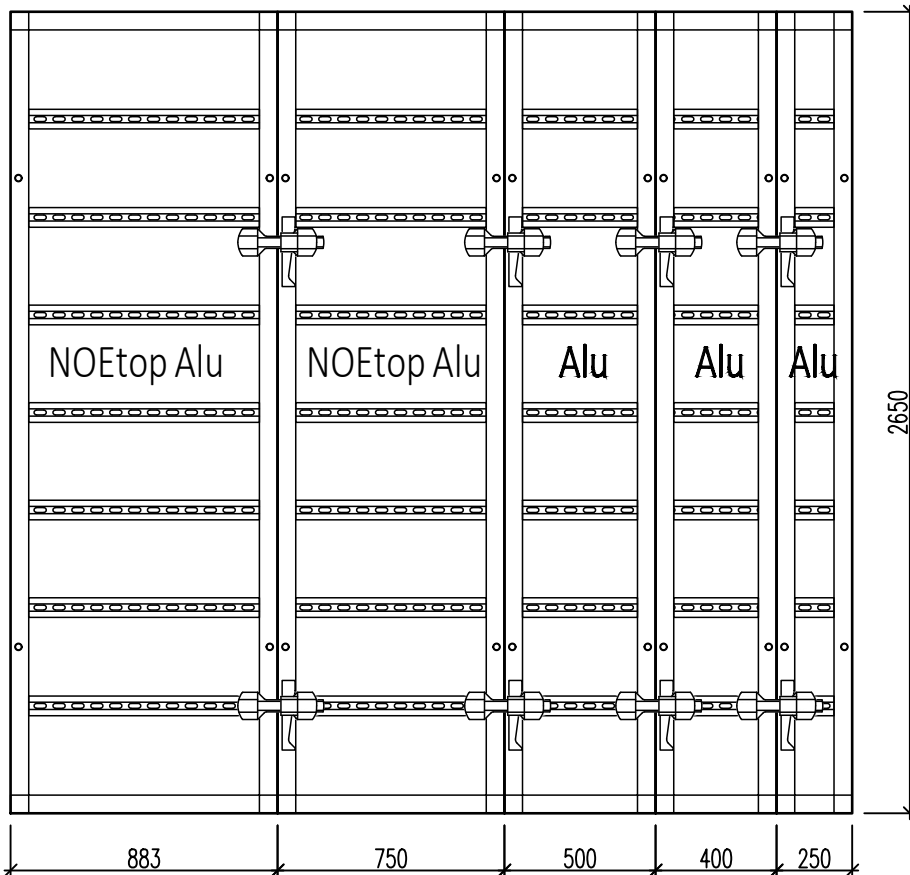

Panel height 1325 mm

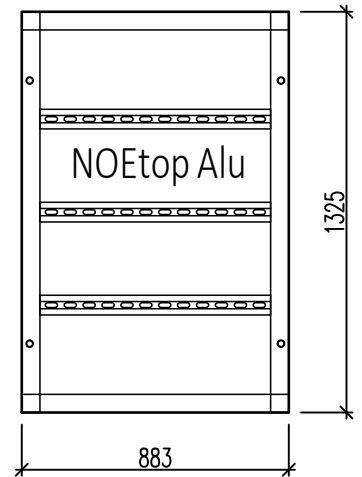
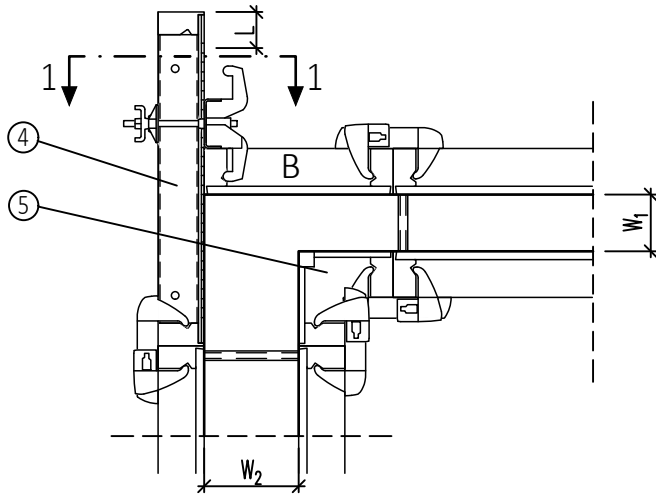

Table of panels

Part No.	Width mm	weight kg
Height 2650 mm		
467681	900	65
167322	883	64
167324	750	57
167326	550	46
167328	500	44
167330	450	42
167336	250	31
Height 1325 mm		
167340	883	34
167382	750	31
167384	550	25
167385	500	23
167387	450	22
167389	250	16

14.2 Corner solution with EC panel ECP NOEtop Alu

For wall thicknesses  $W_1$   
 150, 200, 250, 300, 350 mm (L=87.5 mm = centre of 1st hole)  
 Hole pattern in ECP with holes at 50 mm spacing.



Section 1-1

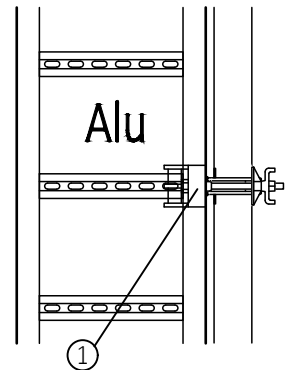

(pushed over hat profile)

The corner in the diagram can also be constructed as a mirror image.

(For installation of the compensation piece see NOEtop)

Wall thickness  $W_2$  for NOEtop Alu panel

- 1 Multiclaw Part No. 164030
- 2 Wing nut with plate Part No. 691700
- 3 Tie rod 30 cm Part No. 670300
- 4 NOEtop Alu EC panel 883
- 5 NOEtop Alu internal corner

Width B (panel)	Wall thickness $W_2$
450 mm	200 mm
500 mm	250 mm
750 mm	500 mm

Corner solutions for other wall thicknesses and with EC angle see corner solutions NOEtop.

Corner connection detail

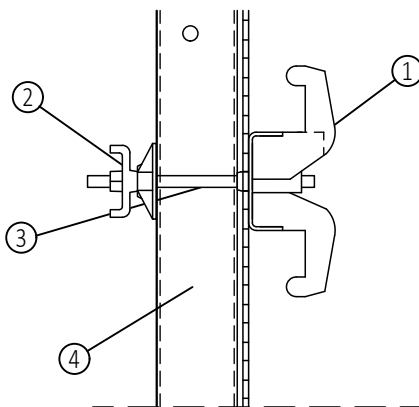

Number of connections		
	Panel height	Number
☝	2650 mm	3
	1325 mm	2

### 14.3 Extending NOEtop Alu

#### 14.3.1 Extending with side-on and end-on panels

(walkway brackets not shown)

Extension up to 500 mm

Tie rods at the top only.

Extension 750 - 883 mm

Tie rods top and bottom, the top of the end-on panels is tied with tying claws at the joint.

Extension 1325 mm high

Elevation

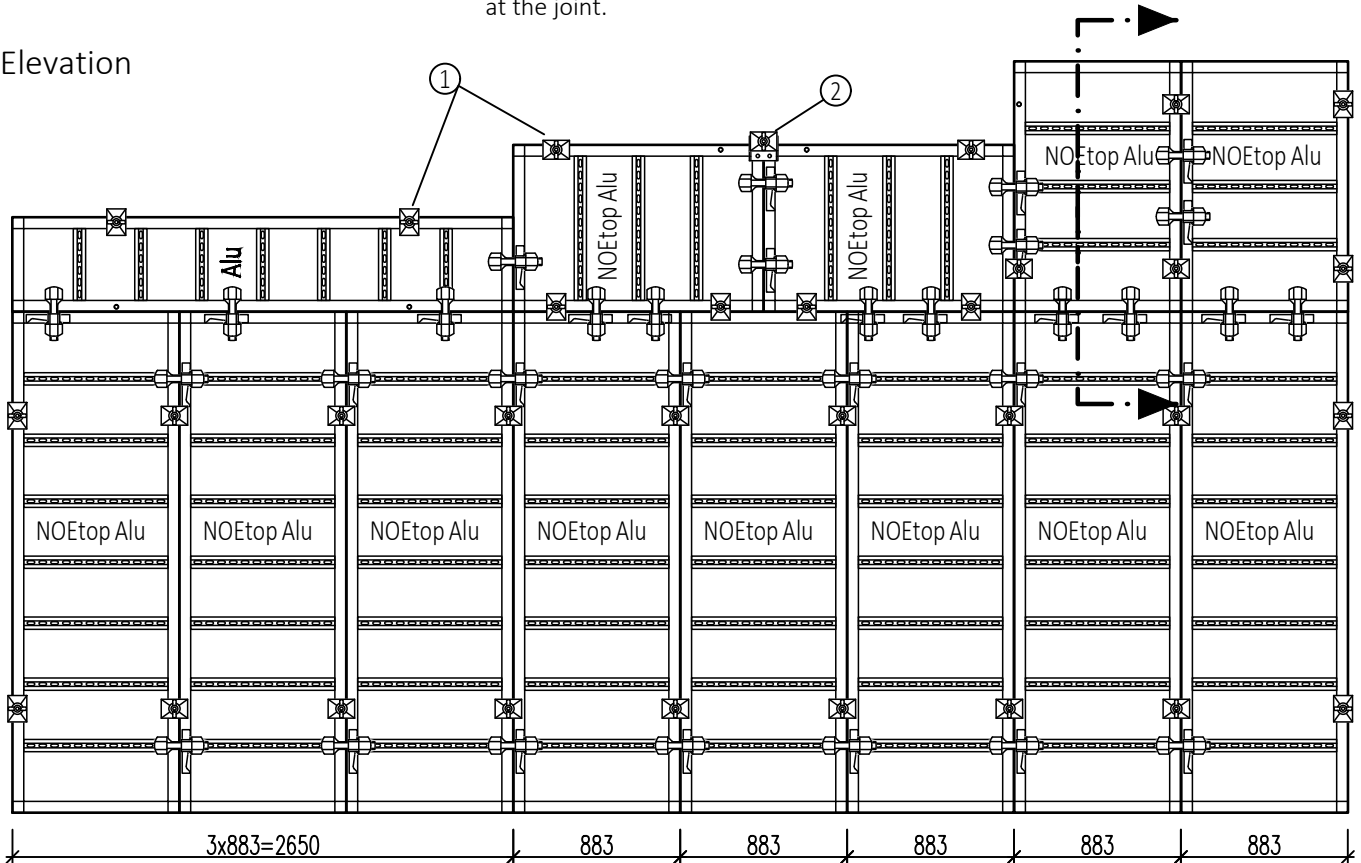

Horizontal connections of the extended panels:

- For panel 2650 mm 3 Toplock per panel
- For panel 883 mm 2 Toplock per panel

- 1 Swivel plate with wing nut Part No. 691700
- 2 Tying claw Part No. 137500 and swivel plate with wing nut Part No. 691700 (at the joint, over top of the panel)

Section

Walkway bracket

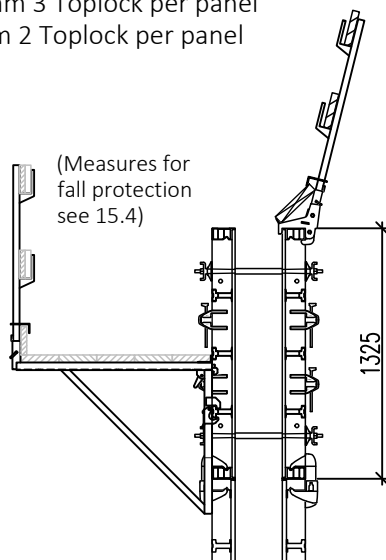

The attached platform brackets (spacing, number) and selection of scaffold planks must comply with regulations for working scaffolds !  
→ see 15.2

## 15. Crane transport, working scaffolds and stabilizers

### 15.1 Using cranes to transport panels

#### 15.1.1 Crane transport general advice

When using crane bows, lifting pins and transport hangers

- Observe the relevant operating instructions!
- Check the condition of the transport equipment before each use!
- Check that the load is correctly seated and the transport equipment is secured before each lift!

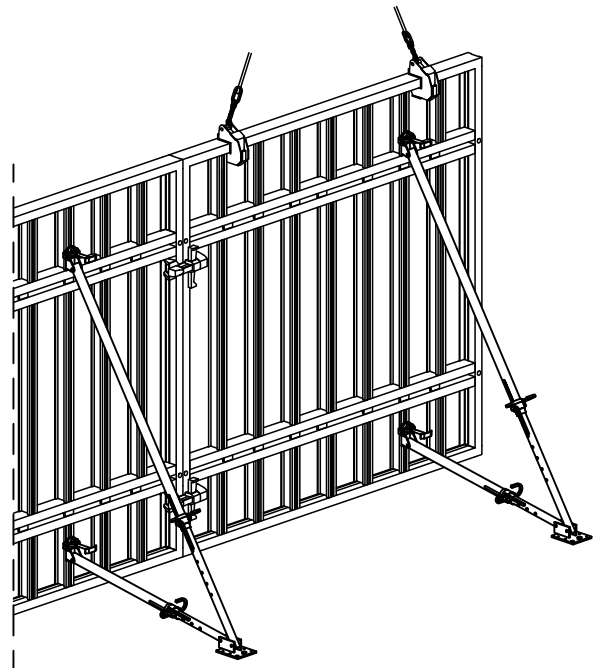

#### Moving panels:

(refer Assembly instructions 3.2.2)

1. Attach the crane hook to the panel and place the crane rope under light tension.
2. Detach the connections to the other formwork elements and release the stabilizers from the base.
3. Lift the panel with the crane.
4. After placing down the panel, secure the panel against falling over before detaching the crane bow.

(see 1.2).



Observe the lifting equipment regulations during transport operations using the crane, erecting panels and installing of working places!

#### 15.1.2 Transporting several panels in a stack using 4x transport hangers

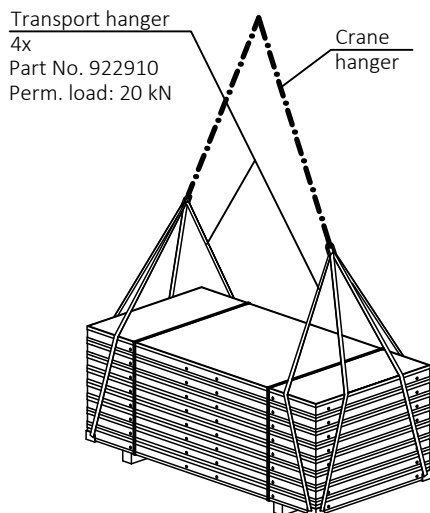

Transporting panel stacks is only allowed using 4x transport hangers. Permissible stack weight: 2000 kg!

#### Requirements for use:

- Form the stack with elements of the same width that fit neatly over one another.
- The upper layers may contain combinations of smaller width panels if no gaps occur between the elements and each element is held in place by at least 2 round slings.
- The bottom layer in the stack must always be composed of one element.
- Stack height max. 1.25 m, i.e. 10 NOEtop panels, assuming that the max. permissible load is not exceeded.
- Use a 2x hanger, for element widths in excess of 2.0 m use a 4 strap hanger.

Unsuitable stack

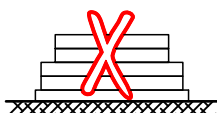

Suitable stack

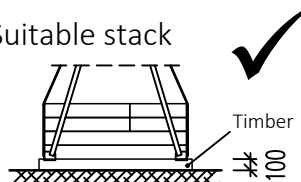

15.1.3 Transporting individual panels horizontally by crane using lifting pins

**Correct**

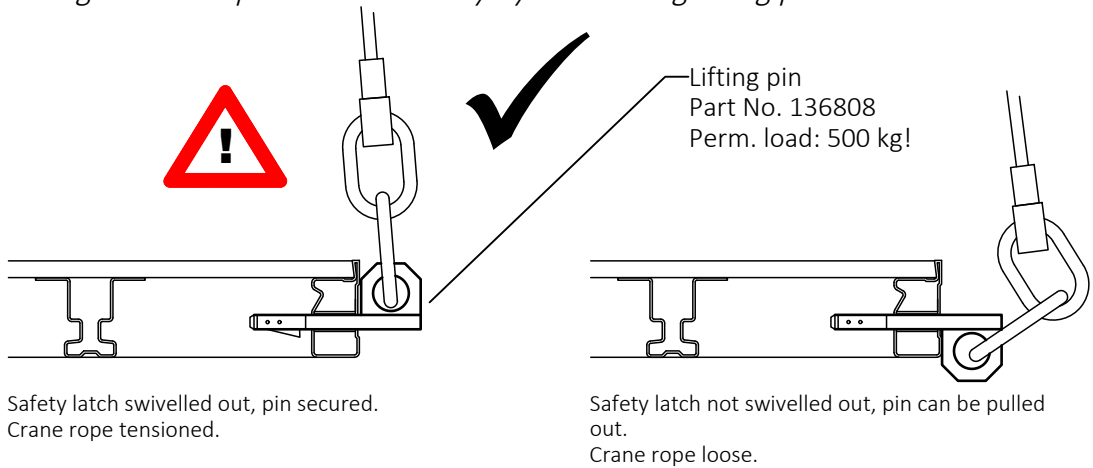

**Incorrect**

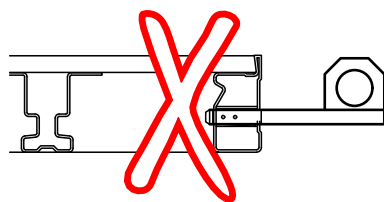

Pin not fully inserted, cannot be safely transported!

Operating instructions of the lifting pin must be observed!

15.1.4 Transporting individual panels vertically by crane with crane bow

Panel with finished side upwards

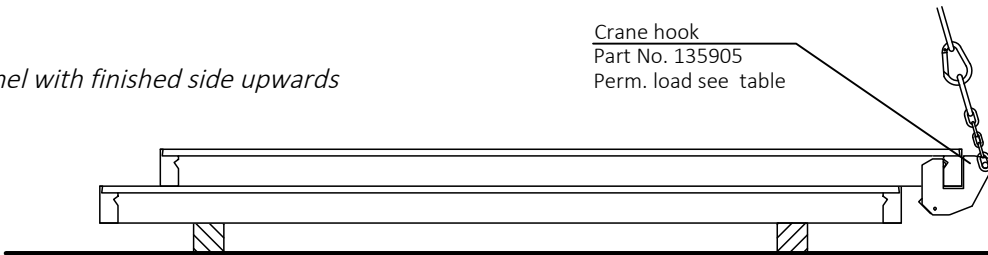

Crane hook  
Part No. 135905  
Perm. load see table

Panel vertical



Panel with finished side downwards

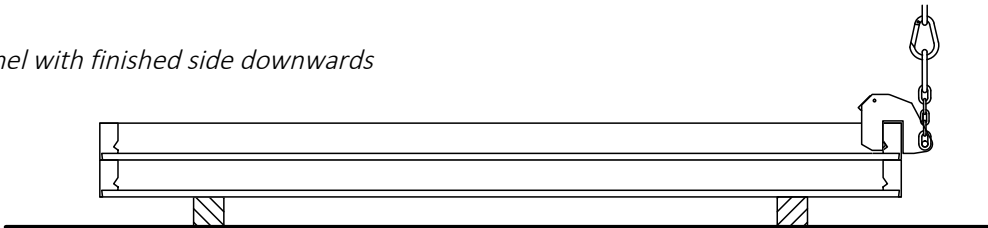

Perm. load in relation to load direction

	Vert. pull 90°	Incl. pull 60°	Incl. pull 45°
	Perm. T [kg]	Perm. T [kg]	Perm. T [kg]
When using NOEtop boards exclusively	2000	1500	1200
When using NOEtop Alu panels or combining NOEtop with NOEtop Alu	1000	750	600

15.1.5 Attaching the crane hook

Observe the requirements of the crane hook operating instructions.

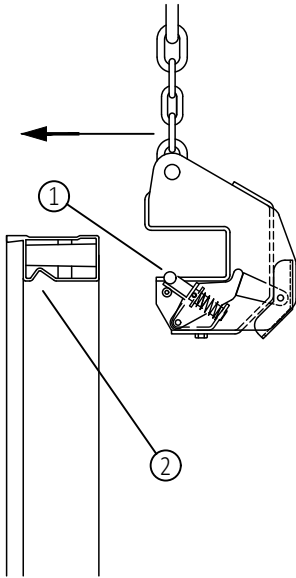

Push the crane hook with some force over the edge profile of the panel until it meets the stop. The safety pin is pushed downwards and inwards by this action and springs up and out again automatically in the area of the nib and secures the crane hook.

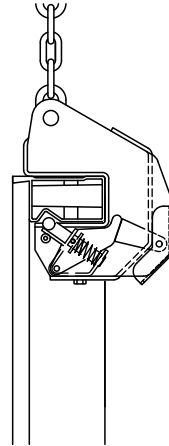

- 1 Safety pin
- 2 Nib
- 3 Release lever

15.1.6 Detaching the crane bow

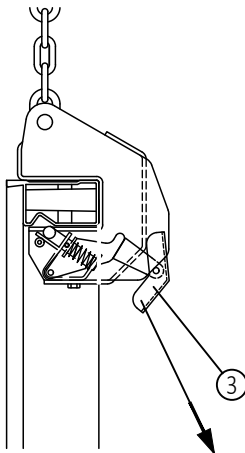

Pull the release lever downwards at the angle shown by the arrow. The safety pin is pressed in and the crane bow can now be released from the panel.

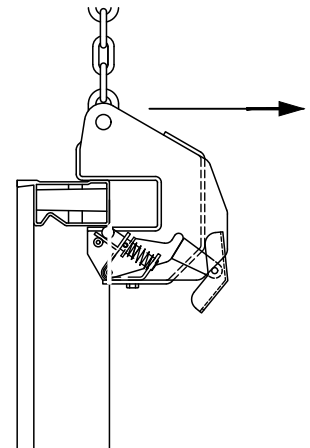

To release the crane bow whilst standing on the ground, insert a bent piece of wire into the hole in the release lever and pull it.

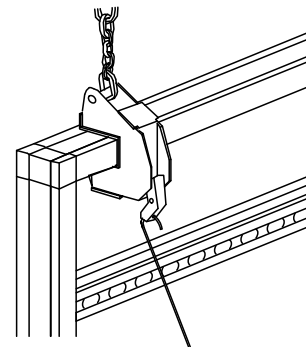

### 15.1.7 Transport small items with NOE Box

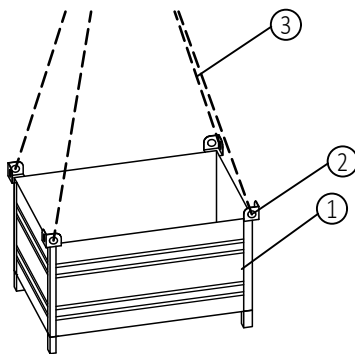

- 1 NOE Box Part No. 697598
- 2 Eyes for attaching to crane hooks
- 3 Sling ropes from crane

NOE boxes are intended for the safe transport of small items (element connections, tie rod accessories etc.). Alternatively you can use robust bags.



Transport small items in secure bundles e.g. in NOE boxes.  
Max. total weight per box: 20 kN (2000 kg)!

Long accessories such as bundles of bracing or platform brackets must be secured with steel bands or be loaded and unloaded safely by other methods e.g. on pallets for slab props (see 15.1.8).

### 15.1.8 Transport of stabilizers and the like with NOE pallets

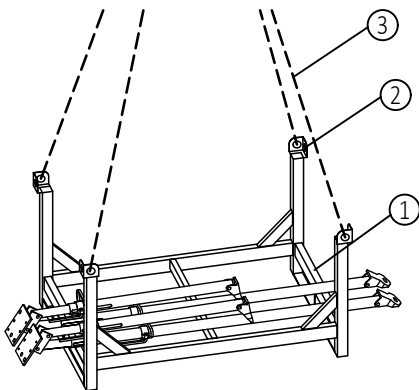

- 1 NOE pallet Part No. 697599
- 2 Eyes for attaching to crane hooks
- 3 Sling ropes from crane

In order to transport, load and unload long accessories safely (stabilizers, bracing, etc) they should be stacked on NOE pallets or bundled.



Bundle long accessories for safe transport e.g. in NOE pallets.

Max. load per pallet: 16.5 kN (1650 kg)!

### 15.1.9 Transporting parts with NOEcase

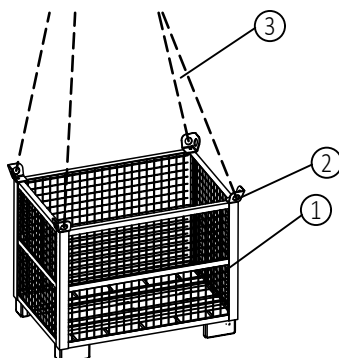

- 1 NOEcase Part No. 697599
- 2 Eyes for attaching to crane hooks
- 3 Sling ropes from crane



Max. load: 1000 kg!

15.2 NOEtop walkway brackets

Working scaffold in acc. with DIN EN 12811-1  
 Scaffold class 2 - max. 150 kg/m<sup>2</sup> uniformly distributed  
 Max. effective width 1.90 m per bracket

If walkway brackets are to be used, the formwork must be structurally stable, e.g. stabilizers attached to this side of the panels.

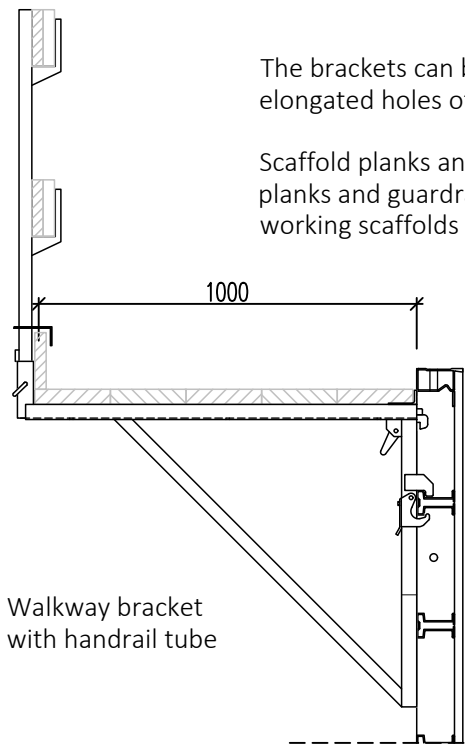

The brackets can be attached to the hat profile (end-on panels) or the elongated holes of the hat profile (side-on panels) (see assembly instructions).

Scaffold planks and guardrail boards provided on site. The selection of scaffold planks and guardrail boards railings must take into account the regulations for working scaffolds !



Max. bracket spacing: 1.90 m

Board/plank thickness in mm  
 (scaffold group 2)

Board/plank width	Span in m		
	1,50	1,75	1,90
20 cm	35	40	45
24 and 28 cm	35	35	40

15.2.1 Assembly instructions for walkway brackets with railings and planking

- ◆ Check the following before the walkway brackets are attached:
  - The supporting formwork construction must be structurally stable.
  - The spacing of the brackets complies with DIN EN 12811-1 Working scaffolds
    - ⇒ max. 1.90 m effective width per bracket
  - Position of the walkway brackets
    - ... in the upper hat profile
      - ⇒ scaffold plank at the front can only be attached after mounting, the formwork since first the crane hook has to be fixed
    - ... as fall protection at heights > 2,00 m
      - ⇒ hang walkway brackets lower if necessary
  - On the first element use working scaffold with hatch!

- ◆ Press and keep pressed the release, which opens the release lever (bottom) and securing slots (top) and allows the walkway bracket to be attached.

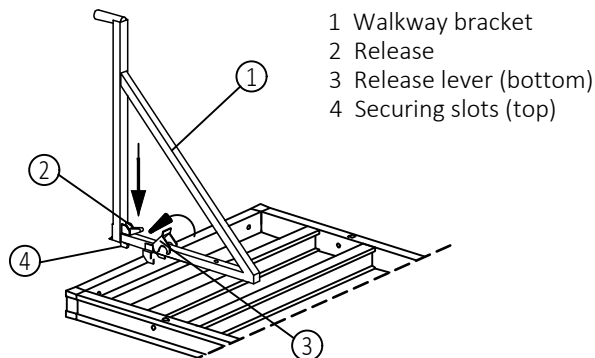



# NOEtop formwork



◆ On to a horizontal hat profile:

Introduce the bottom hook of the bracket into the groove on the hat profile. Let go of the release and the release lever (bottom) closes automatically. The brackets may be attached in any position on the hat profile.

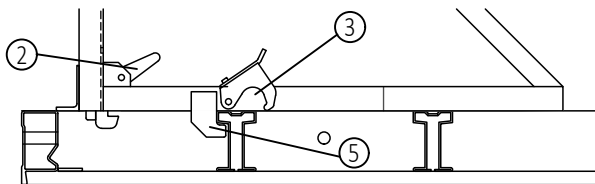

◆ On to a vertical hat profile:

The top hook of the bracket is introduced into the elongated hole in the hat profile. Let go of the release and the securing slide (top) moves forward and wedges the hook into the elongated hole.

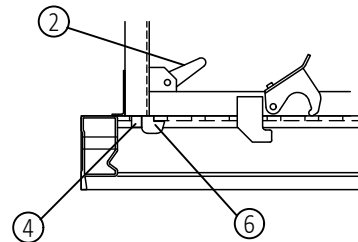

◆ Insert the handrail tube into the bracket and secure with plug

- 1 Walkway bracket
- 2 Release
- 3 Release lever (bottom)
- 4 Securing slide (top)
- 5 Bottom hook
- 6 Top hook
- 7 Handrail tube
- 8 Plug

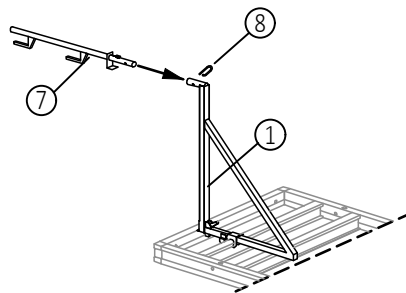

 Check once more that the brackets are securely seated!

◆ Attaching planking and railings

 Attach the crane hook in the edge profile:  
If the walkway bracket is attached to the top of the panel, the front scaffold board can only be installed after the panel is structurally stable and the crane hook has been detached.

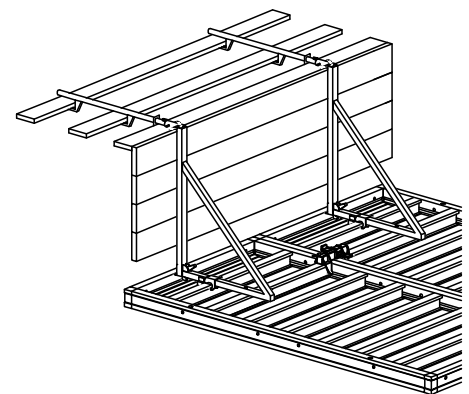

Attach guardrail boards and toeboard

 Before each first use must be checked that the scaffold is attached correctly to the edge profile and that the safety catch is locked (see 15.3).

◆ Dismantling the walkway bracket

To dismantle, lay the formwork elements with complete scaffolding unit down and take off the individual components from that position. This is carried out in the reverse order to the assembly.

15.3 NOEtop hinged scaffold

The panel must be structural stable in order for the hinged scaffold to be used, i.e. e.g. stabilizers attached to this side of the formwork.

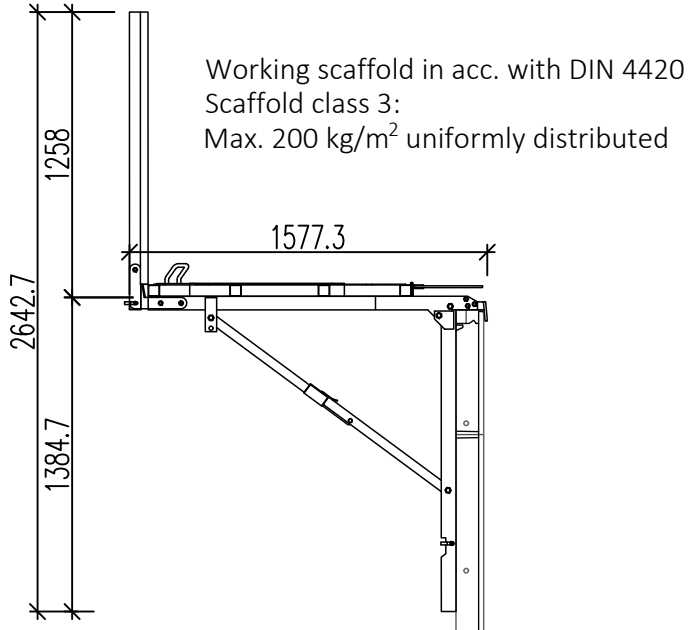

15.3.1 Detail for attaching to the edge profile

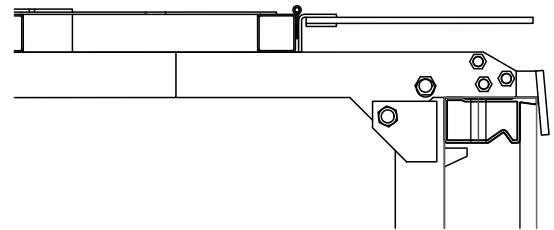

Before each first use must be checked that the scaffold is attached correctly to the edge profile and that the safety catch is locked.

15.3.2 Assembly instructions for the hinged scaffold.

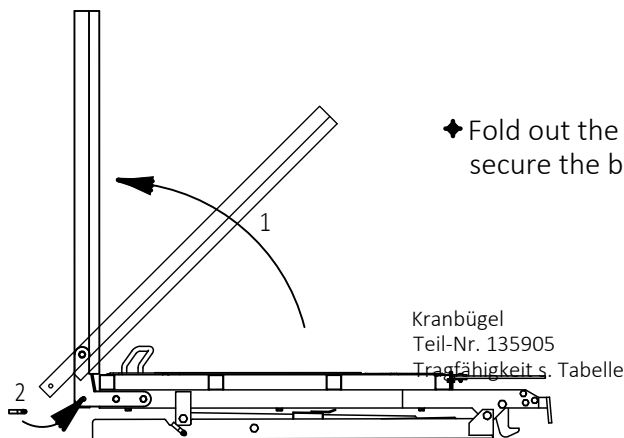

- ◆ Fold up the cover and attach the crane hook to the crane bow.  
The safety clamp is open.

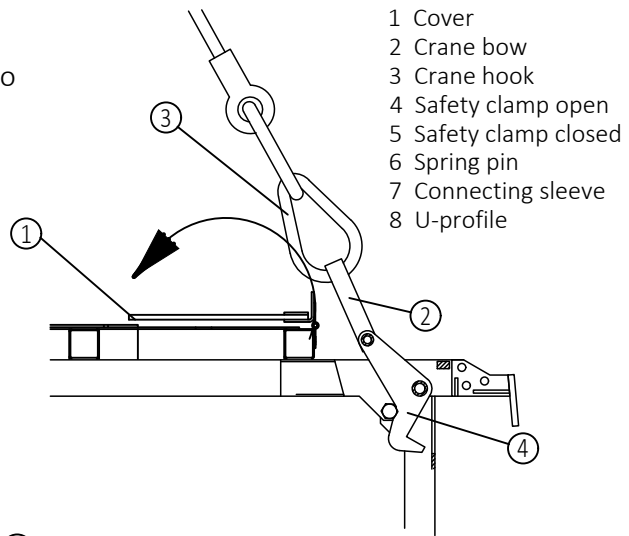
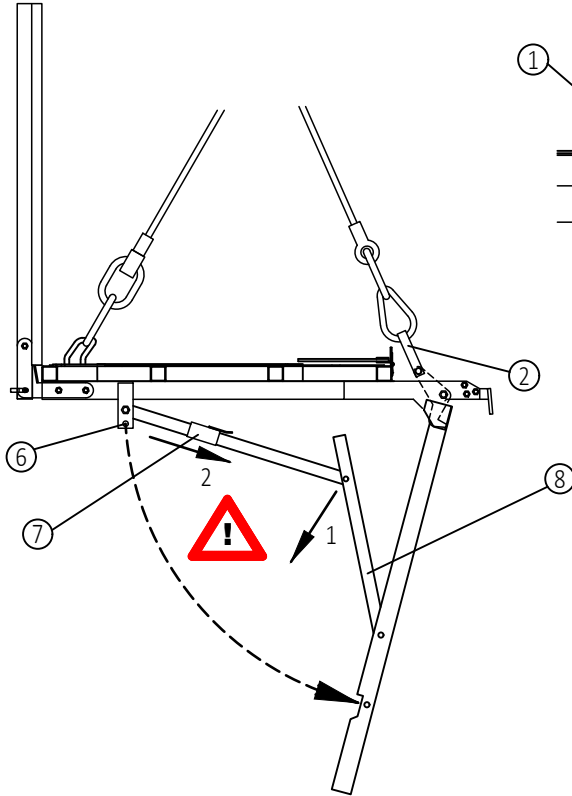

- 1 Cover
- 2 Crane bow
- 3 Crane hook
- 4 Safety clamp open
- 5 Safety clamp closed
- 6 Spring pin
- 7 Connecting sleeve
- 8 U-profile

- ◆ Lift the bracket and fold it out:
  - Remove spring pin, the scaffold folds out automatically
  - Push the connecting sleeve with the red label up to the u-profile.

- ◆ Attach the hinged scaffold to the profile (here it is shown attached to the edge profile). The safety clamp closes after the load on the crane hook is relieved.

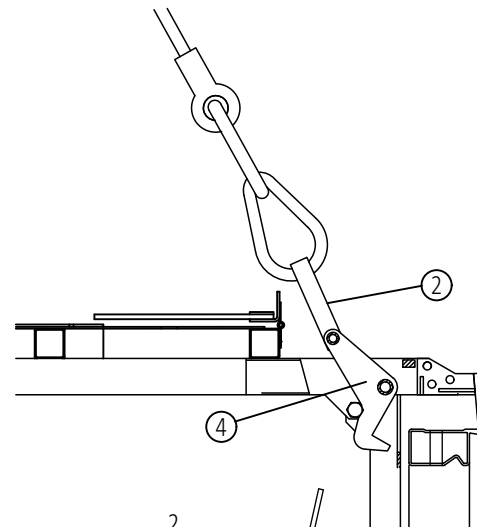

- ◆ After the scaffold unit has been attached, detach the crane, fold the crane bow at 90° and close up the cover.

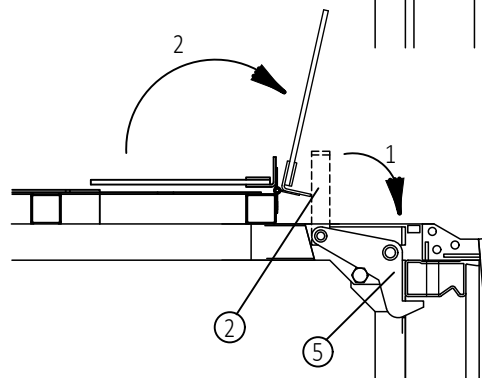

Before anyone accesses the scaffold, a competent person must check to see that it is properly folded out, the connecting sleeve has been pushed down to the stop and the bracket is correctly attached.

15.3.3 Attachment of ladder and ladder support

To provide safe access and egress, the ladder is fastened to the hinged concreting scaffold with hatch.

- ◆ To attach a ladder, remove a locking pin from the circular rod and pull back the rod as far as the second strap. Position the ladder, push the rod through the ladder rung and front strap and secure with pin.

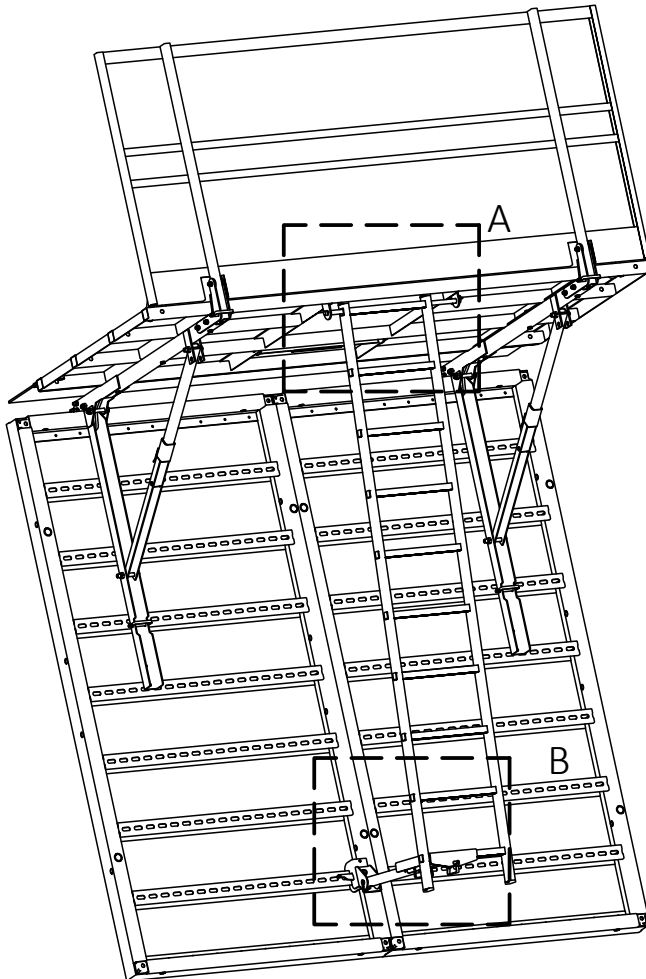

Detail A

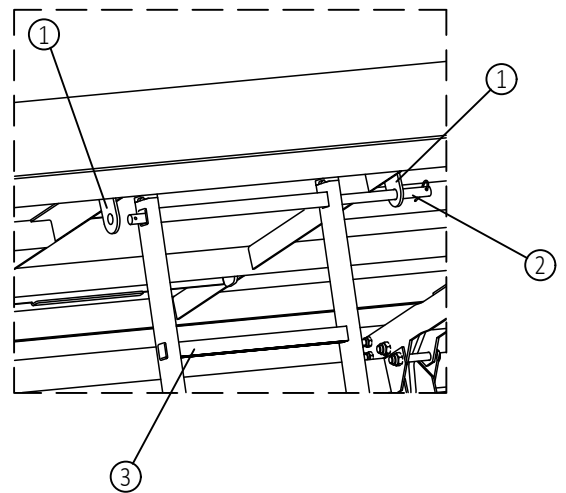

- ◆ Attach the ladder support to the ladder and secure with the spring pin. Fasten it in place with stabilizer connector in the hat profile of the panel.

Detail B

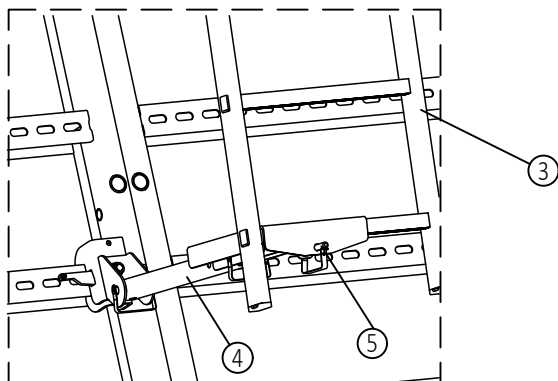

- 1 Ladder strap
- 2 Circular rod for attachment secured with 2 pins
- 3 Ladder
- 4 Ladder support Part No. 550023
- 5 Spring pin

- ◆ The front part of the planking can be folded up to allow the crane bow to be attached. The planking can be folded down again after the unit is structurally stable and the crane bow is detached.

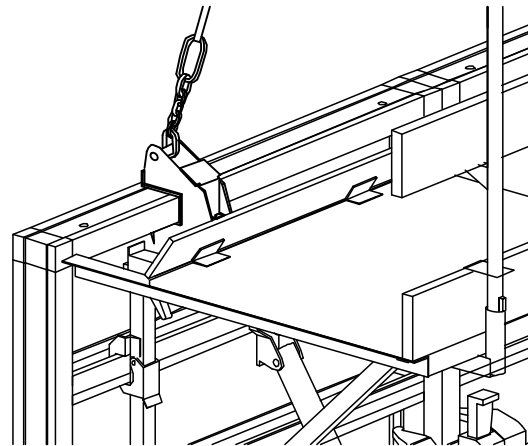

15.3.4 Inside and outside corner solution

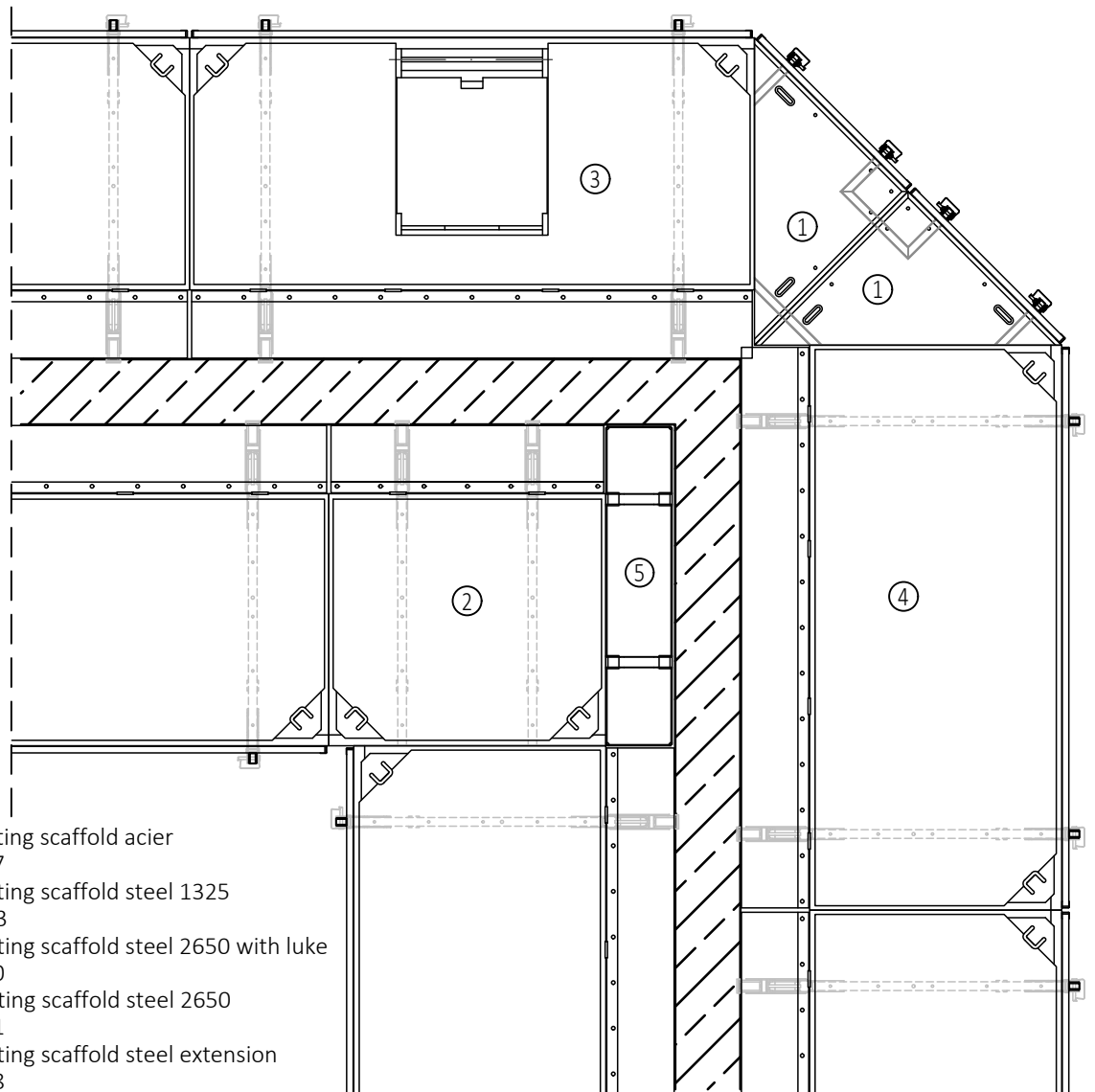

- 1 NOEtop concreting scaffold acier  
Part no. 552267
- 2 NOEtop concreting scaffold steel 1325  
Part No. 552243
- 3 NOEtop concreting scaffold steel 2650 with luke  
Part no. 552240
- 4 NOEtop concreting scaffold steel 2650  
Part no. 552241
- 5 NOEtop concreting scaffold steel extension  
Part no. 552268

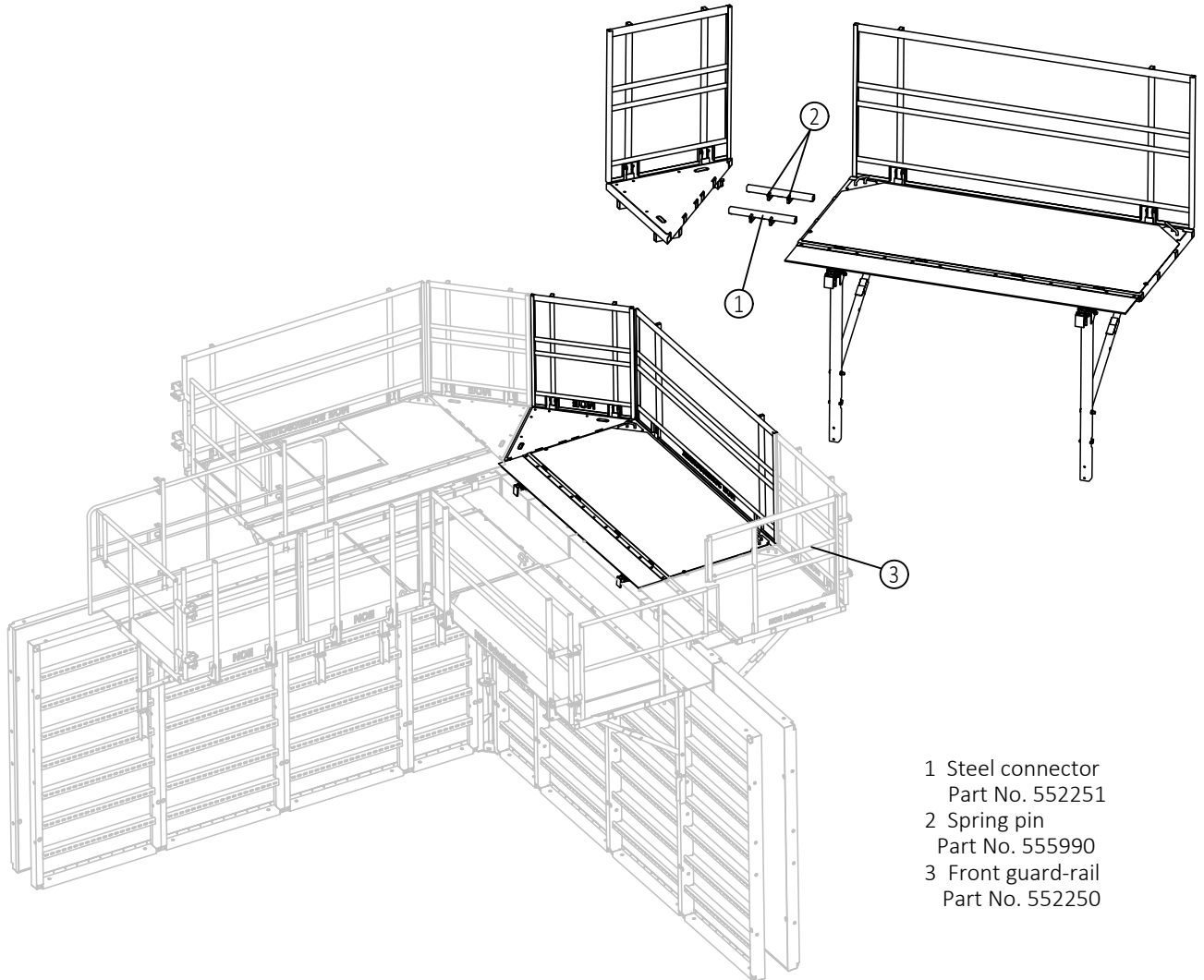

- 1 Steel connector  
Part No. 552251
- 2 Spring pin  
Part No. 555990
- 3 Front guard-rail  
Part No. 552250

### 15.4 NOEtop fall protection

From a formwork height of 2.00 m there must be fall protection measures on both sides, i.e.

- a) the second side also has a walkway bracket attached or
- b) a railing is attached to the second face formwork.

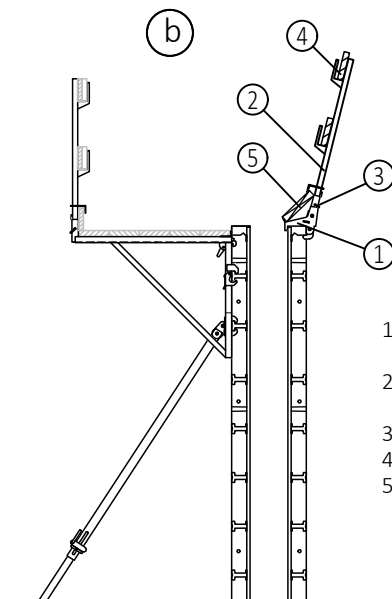
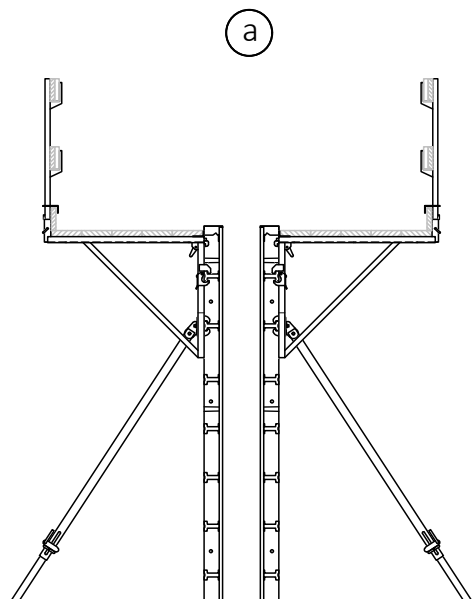

Clamp the clamp support to the edge profile by driving in the wedge. Insert the handrail tube into the bracket and secure with plug. Place guard rail boards and platform board in position.

- 1 NOEtop clamp support  
handrail tube Part No. 552214
- 2 Handrail tube Part No. 111400  
or Part No. 111403
- 3 Locking pin Part No. 890834
- 4 Guard rail board
- 5 Platform board

15.5 NOEtop scaffold platform 2600 mm with hatch

Section

Plan

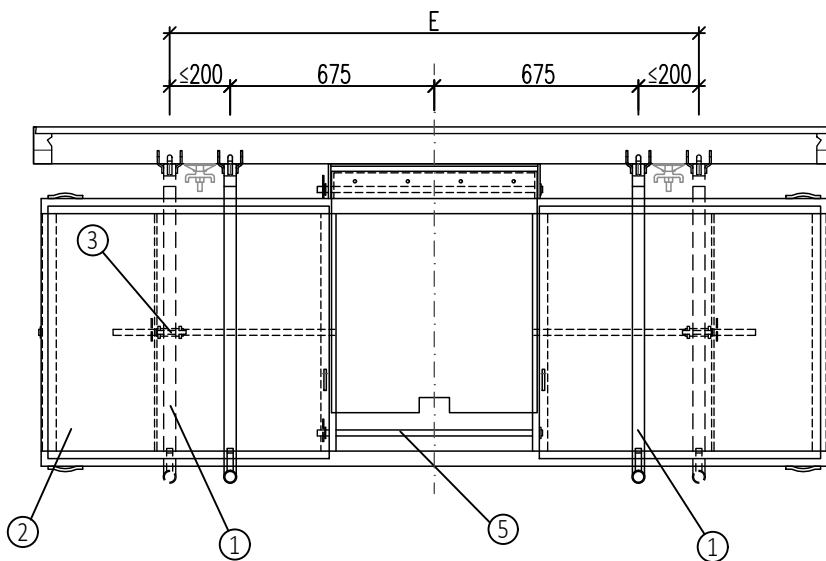
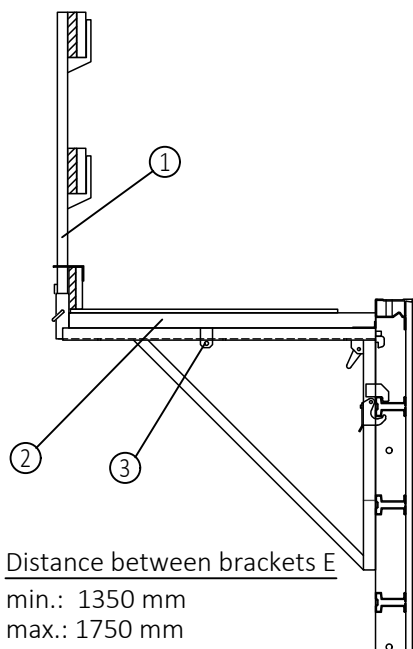

- 1 Walkway bracket with handrail tube
- 2 Working platform with trapdoor  
Part No. 550010
- 3 Attachment slide (moveable)
- 4 Spring pin
- 5 Circular rod for attaching ladder

15.5.1 Attachment of ladder and ladder support

- ◆ Attach 2 walkway brackets at the same height to the panel (see 15.2).
- ◆ Put the platform in place. Ensure that the 2 fastening slides enclose the brackets and secure with spring pin.

Detail A

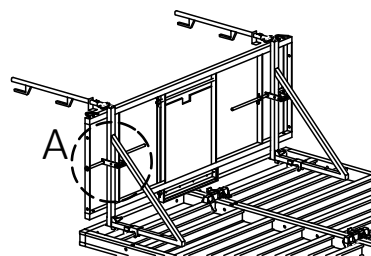
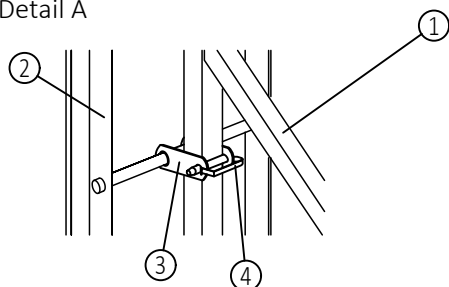

- ◆ Attaching the guardrail (see 15.2).
- ◆ To attach a ladder, remove a locking pin from the circular rod and pull back the rod as far as the second strap. Position the ladder, push the rod through the ladder rung and front strap and secure with pin.

Detail B

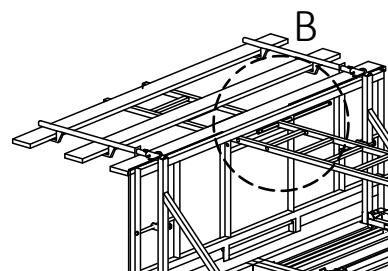
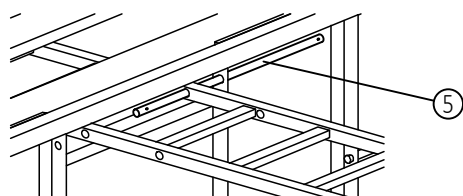

- ◆ Attach the ladder support to the ladder and secure with the spring pin. Fasten it in place with stabilizer connector in the hat profile of the panel.

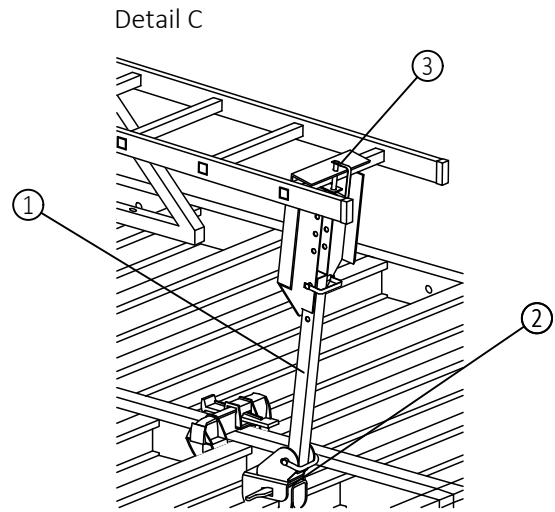
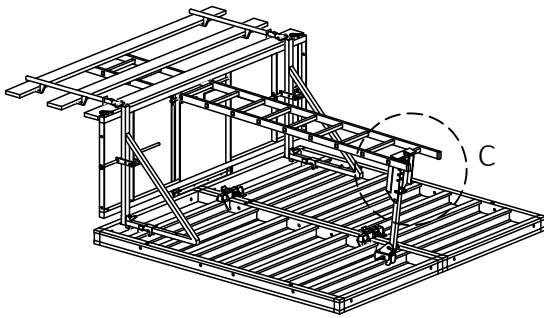

- 1 Ladder support  
Part No. 550023
- 2 Stabilizer connector  
Part No. 697032
- 3 Spring pin

15.5.2 End protection with NOEtop front guard-rail

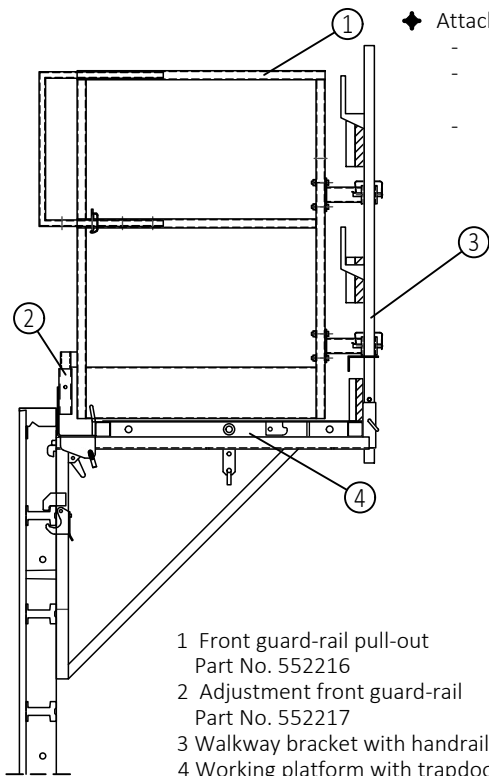

- ◆ Attach the NOEtop front guard-rail:
  - Push the adapter over the walkway bracket and secure with plug.
  - Insert the Noetop front guard-rail into the adapter and swing to the handrail tube, until the holding brackets are attached to the handrail tube.
  - Secure the holding brackets with plug.

- 1 Front guard-rail pull-out  
Part No. 552216
- 2 Adjustment front guard-rail  
Part No. 552217
- 3 Walkway bracket with handrail tube
- 4 Working platform with trapdoor  
Part No. 550010

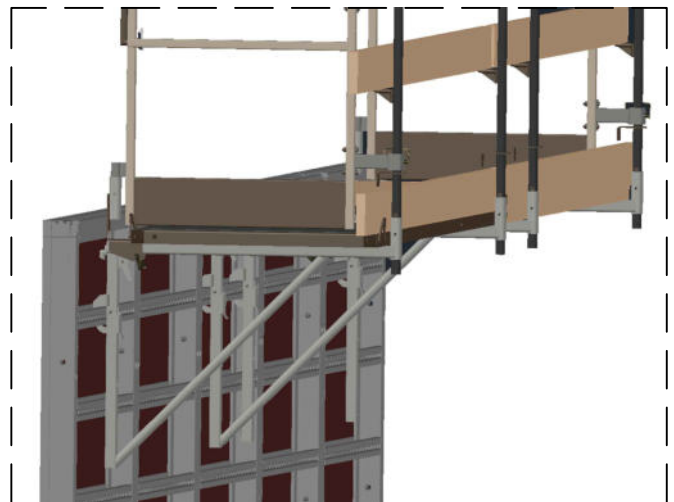



15.6 Stabilizers up to 5000 mm

Prop push-pull 2770-5000 mm

Part No. 697028 Weight 25,7 kg  
perm. load capacity 29,7 - 6,8 kN

Prop push-pull 2100 - 3650 mm

Part No. 697027 Weight 19,1 kg  
perm load capacity 29,7 - 12,8 kN

Prop push-pull 1000-1510 mm

Part No. 697026 Weight 9,4 kg  
perm. load capacity 29,7 kN

The props can be attached with the stabilizer adapter or with the hinge end joint and hammer-head bolt.

- 1 Prop push-pull top
- 2 Prop push-pull bottom
- 3 Supporting plate Part No. 697014
- 4 L-pin D16 Part No. 697010
- 5 Spring pin Part No. 913304
- 6 Stabilizer connector Part No. 697032
- 7 Hinge end joint Part No. 697012
- 8 Hammer-head bolt with handle Part No. 319338
- 9 Uplift safety device

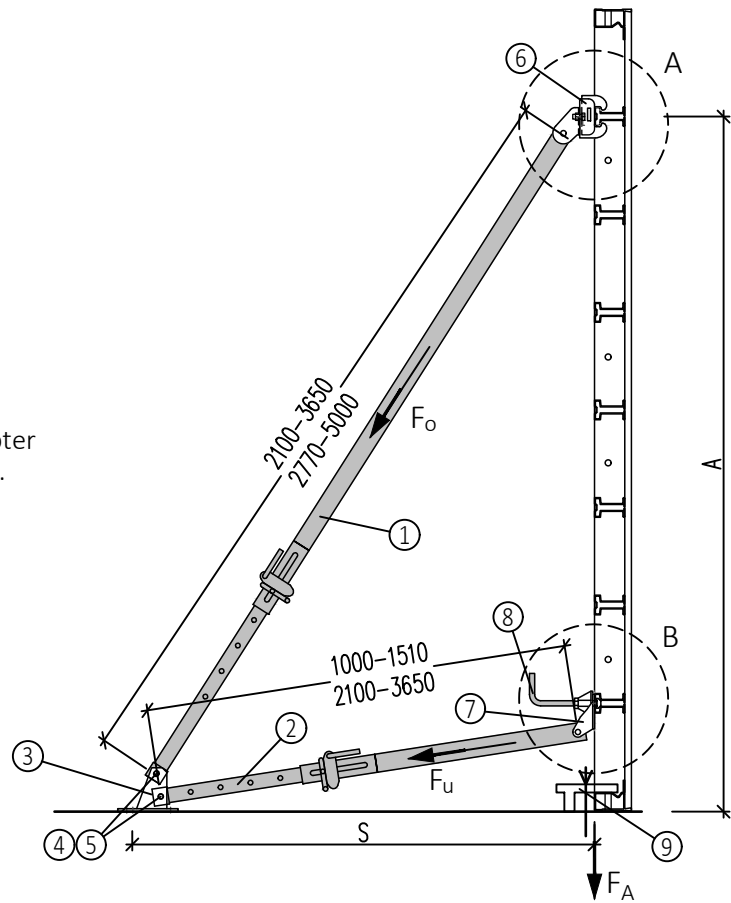

The supporting plates, connections, pins and spring pins are not included in the scope of supply of the props.

Detail A

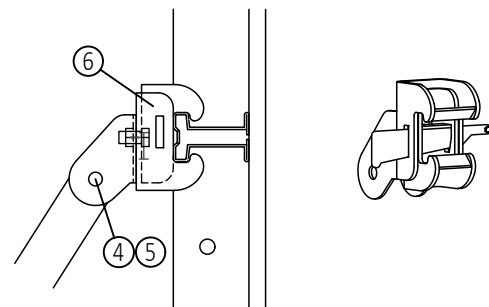

Attaching with stabilizer adapter

Attaching to cross-profile on end-on and side-on panels. The stabilizer connector can be simply suspended on the horizontal hat profile and fixed with the wedge.

Stabilizer connector max. 15 kN

Detail B

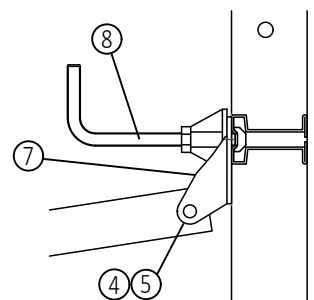

Attaching with hammer-head bolt

Attached to the elongated hole of the hat profile by hammer-head bolt with handle and integral sprint for end-on and side-on panels.

When the fastening with the hammerhead bolt is below approx. 60° no more than a max. 8 kN may be transferred into the hat profile.

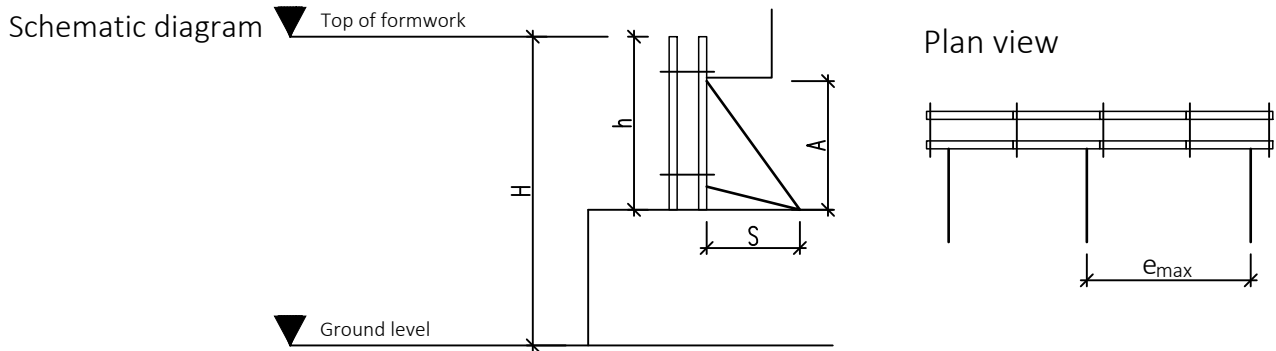

Table for effective widths and loads for attachment by stabilizer adapter

Panel height h [m]	Part number of top strut	Propping height A [m]	Distance S [m]	Height H above ground up to 7 m				Height H above ground up to 25 m			
				e <sub>max</sub> [m]	Loads at e <sub>max</sub>		F <sub>A</sub> [kN/m]	e <sub>max</sub> [m]	Loads at e <sub>max</sub>		F <sub>A</sub> [kN/m]
					F <sub>O</sub> [kN]	F <sub>U</sub> [kN]			F <sub>O</sub> [kN]	F <sub>U</sub> [kN]	
2,65	697027	2,00	1,40	2,65	4,6	1,8	0,5	2,65	7,4	2,9	3,0
3,31	697027	2,30	1,40	2,65	7,2	1,9	1,9	2,65	11,4	3,0	5,8
3,975	697027	3,00	1,60	2,65	8,8	2,6	2,7	2,65	14,0	4,1	7,6
3,975	697028	3,00	2,40	2,65	6,6	2,6	0,0	2,65	10,5	4,1	3,2
4,635	697028	3,65	2,40	2,65	8,4	3,2	1,0	2,50	12,7	4,8	5,1
5,30	697028	4,30	2,40	2,20	8,8	3,1	1,9	1,35	8,6	3,0	4,2
5,30	697133	4,30	3,20	2,65	8,7	3,7	0,0	2,65	13,8	5,9	4,2
6,62	697133	5,60	3,20	2,65	12,6	4,9	2,1	1,95	14,8	5,7	6,6

Table for effective widths and loads for attachment by hinge end joint and hammer-head bolt

Panel height h [m]	Part number of top strut	Propping height A [m]	Distance S [m]	Height H above ground up to 7 m				Height H above ground up to 25 m			
				e <sub>max</sub> [m]	Loads at e <sub>max</sub>		F <sub>A</sub> [kN/m]	e <sub>max</sub> [m]	Loads at e <sub>max</sub>		F <sub>A</sub> [kN/m]
					F <sub>O</sub> [kN]	F <sub>U</sub> [kN]			F <sub>O</sub> [kN]	F <sub>U</sub> [kN]	
2,65	697027	2,00	1,40	2,65	4,6	1,8	0,5	2,65	7,4	2,9	3,0
3,31	697027	2,30	1,40	2,65	7,2	1,9	1,9	1,85	8,0	2,1	4,1
3,975	697027	3,00	1,60	2,40	8,0	2,4	2,4	1,50	7,9	2,3	4,3
3,975	697028	3,00	2,40	2,65	6,6	2,6	0,0	2,00	7,9	3,1	2,4
4,635	697028	3,65	2,40	2,50	8,0	3,0	0,9	1,55	7,8	3,0	3,2
5,30	697028	4,30	2,40	2,00	8,0	2,8	1,8	1,25	8,0	2,8	3,9
5,30	697133	4,30	3,20	2,40	7,9	3,4	0,0	1,55	8,1	3,5	2,5
6,62	697133	5,60	3,20	1,65	7,9	3,0	1,3	1,05	8,0	3,1	3,5

The values in the table apply for wind loads in acc. with DIN 1055-4:2005-3, Inland, wind zone 2, intermediate zone (Zone B), l/h=5 Pressure coefficient 1.8 Solidity 1.0 Reduction factor 0.6 (service life up to 12 months)

Propping height bottom strut: 0.355 m  
 Angle of stabilizer: Approx. 60°  
 Value for influence width per stabilizer: e<sub>max</sub>

In the edge area of the formwork (Zone A, free formwork end or beginning) the maximum influence width of the stabilizers must be halved.

For the calculation of the anchored load F<sub>A</sub> the formwork weight of the NOEtop formwork was taken as 80 kg/m<sup>2</sup>. In addition the listed values contain the partial safety factor 1.5 for the overall stability (DIN 1055-100).

All the given values are characteristic values.

### Assembly

a) Individual parts for stabilizers up to approx. 4.00 m panel height

No.	Description
1	Prop push-pull 2100-3650 mm Part No. 697027 (1)
1	Prop push-pull 1000-1510 mm Part No. 697026 (2)
1	Supporting plate Part No. 697014 (3)
4	L-pin D16 Part No. 697010 (4)
4	Spring pin Part No. 913304 (5)
2	Stabilizer connector Part No. 697032 (6) or
2	Hinge end joint Part No. 697012 (7)
2	Hammer-head bolt with handle Part No. 319338 (8)

Plan bottom support

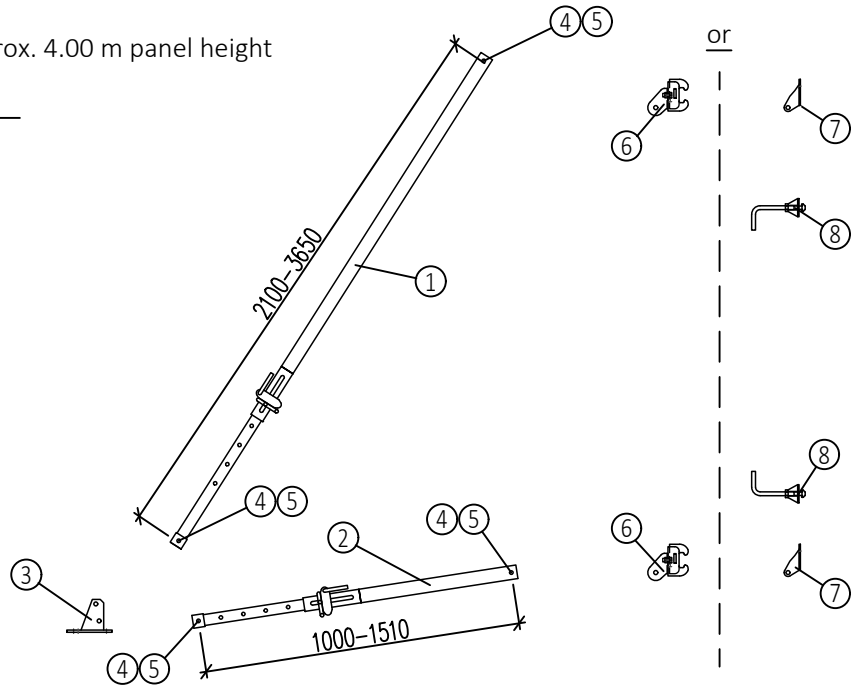
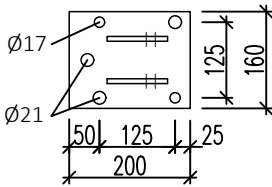

b) Individual parts for stabilizers up to approx. 5.30 m panel height

No.	Description
1	Prop push-pull 2800-5000 mm Part No. 697028 (1)
1	Prop push-pull 2100-3650 mm Part No. 697027 (2)
1	Supporting plate Part No. 697014 (3)
4	L-pin D16 Part No. 697010 (4)
4	Spring pin Part No. 913304 (5)
2	Stabilizer connector Part No. 697032 (6) or
2	Hinge end joint Part No. 697012 (7)
2	Hammer-head bolt with handle Part No. 319338 (8)

b) Individual parts for stabilizers up to approx. 6.62 m panel height

No.	Description
1	Prop push-pull 5000-7500 mm Part No. 697133 (9)
1	Prop push-pull 2100-3650 mm Part No. 697027 (2)
1	Supporting plate Part No. 697014 (3)
4	L-pin D16 Part No. 697010 (4)
4	Spring pin Part No. 913304 (5)
2	Stabilizer connector Part No. 697032 (6) or
2	Hinge end joint Part No. 697012 (7)
2	Hammer-head bolt with handle Part No. 319338 (8)

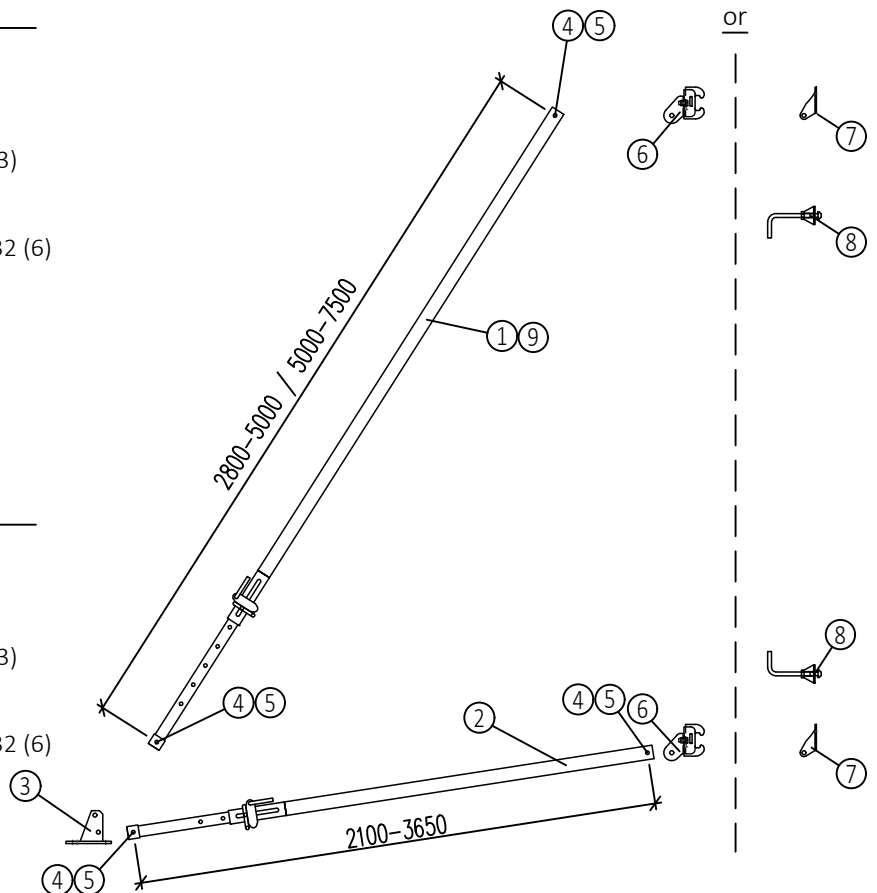

15.7 Stabilizers for high panels

NOE stabilizer 6400 - 10300 mm

**ATTENTION:**  
The strut and the anchors of supporting plate, as well as the formwork construction are subject to structural analysis.

- 1 Raking prop 6400-10300 mm  
Part No. 697036
- 2 Supporting plate Part No. 697014
- 3 L-pin D16 Part No. 697010
- 4 Spring pin Part No. 913304
- 5 Stabilizer connector Part No. 697032
- 6 Hinge end joint Part No. 697012
- 7 Hammer-head bolt with handle Part No. 319338
- 8 Uplift safety device

The props can be attached with the stabilizer adapter or with the hinge end joint and hammer-head bolt.

Plan bottom support

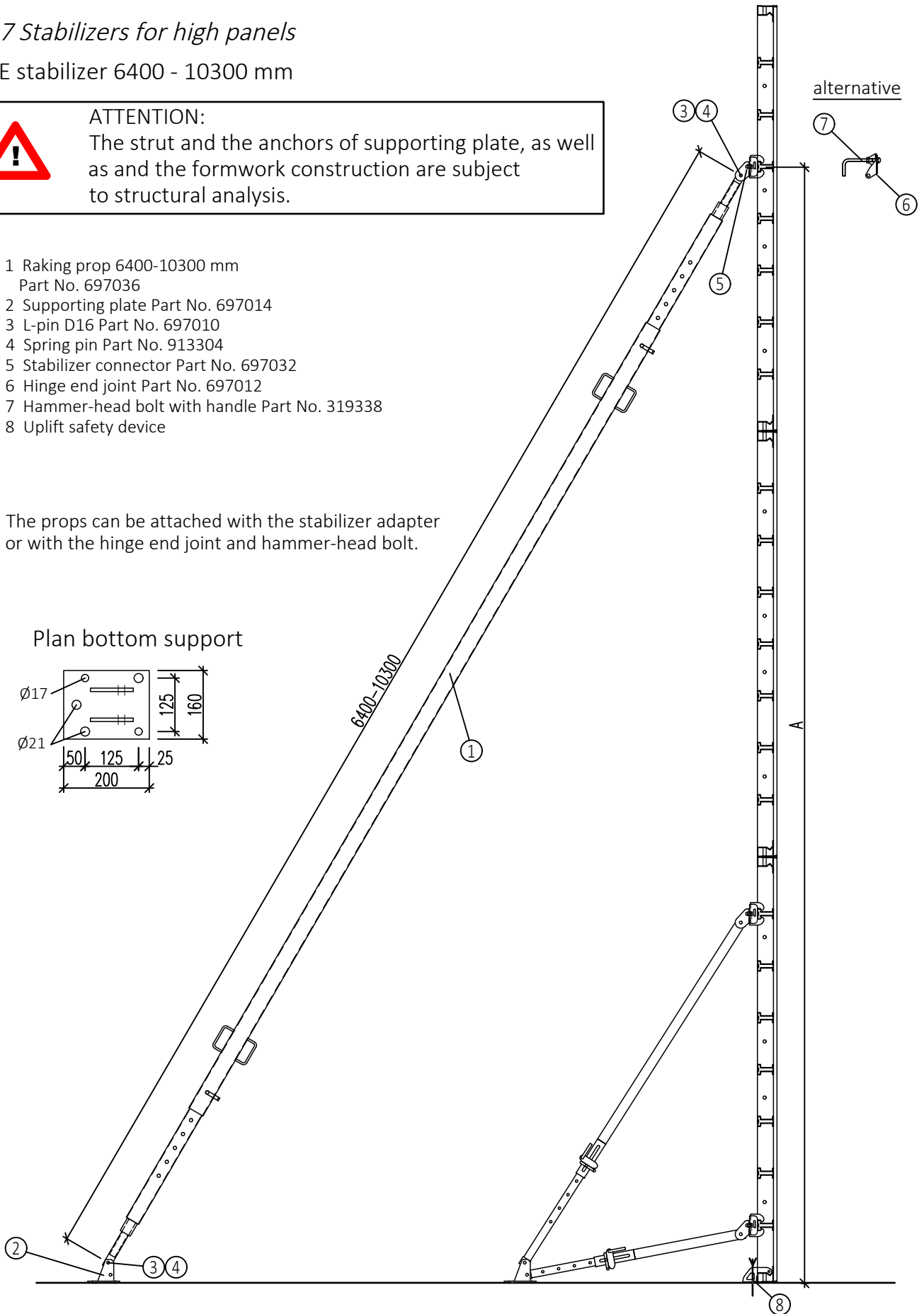
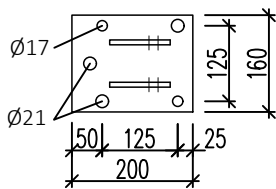

# NOEtop formwork

## 16. Individual parts of NOEtop panels

### 16.1 NOEtop large area panels

Tie rods can also be installed at different spacings along the bracing. This requires separate structural engineering design calculations (on request).

With side-on panels the tie rod holes have the same pattern as the 2650 mm high panel.

#### 16.1.1 NOEtop large panel 2650x5300 mm

Part No. 168051 Weight 932.5 kg

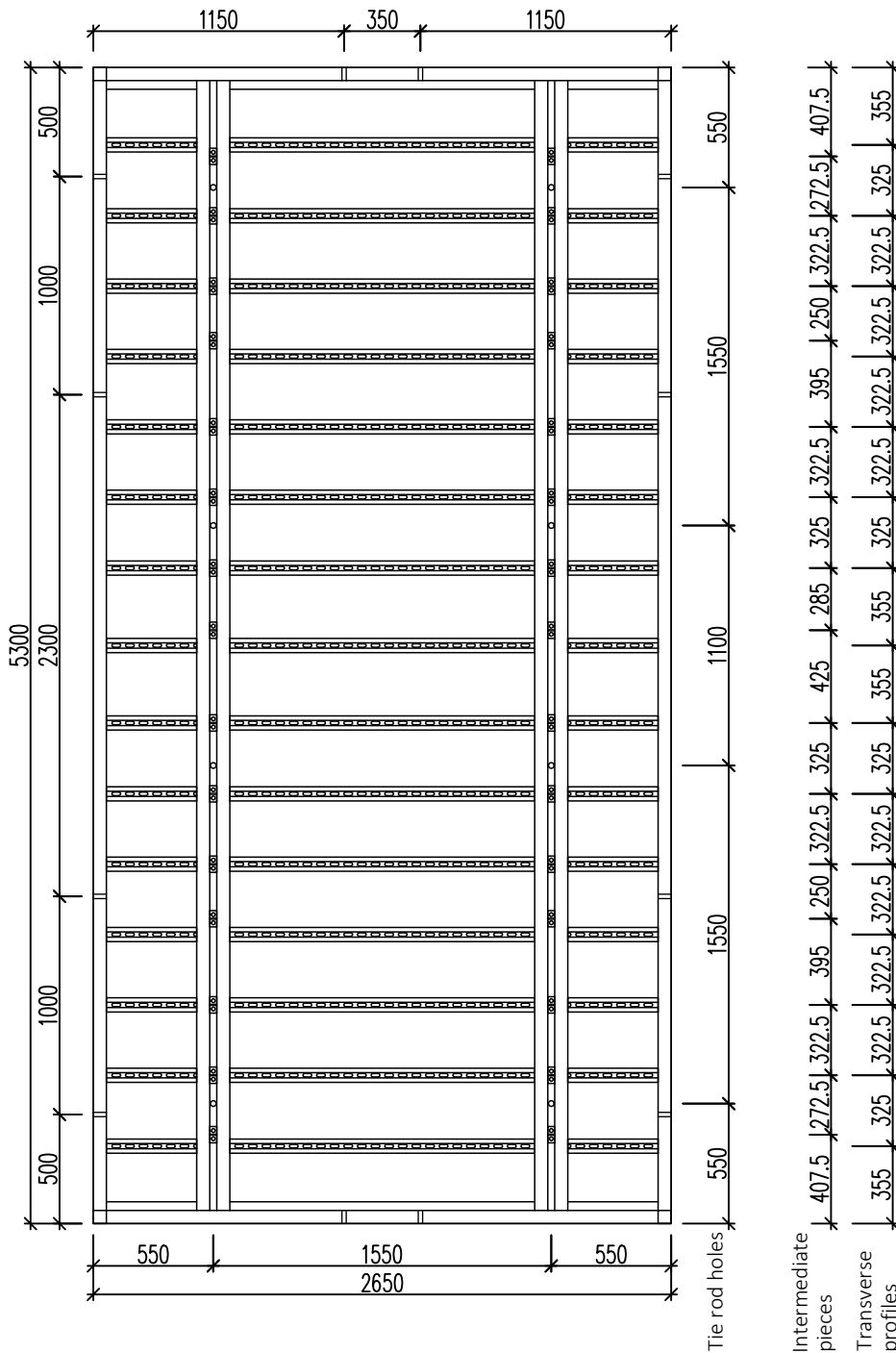

# NOEtop formwork



## 16.1.2 NOEtop large panel 2650x3310 mm

Part No. 168052 Weight 589.9 kg

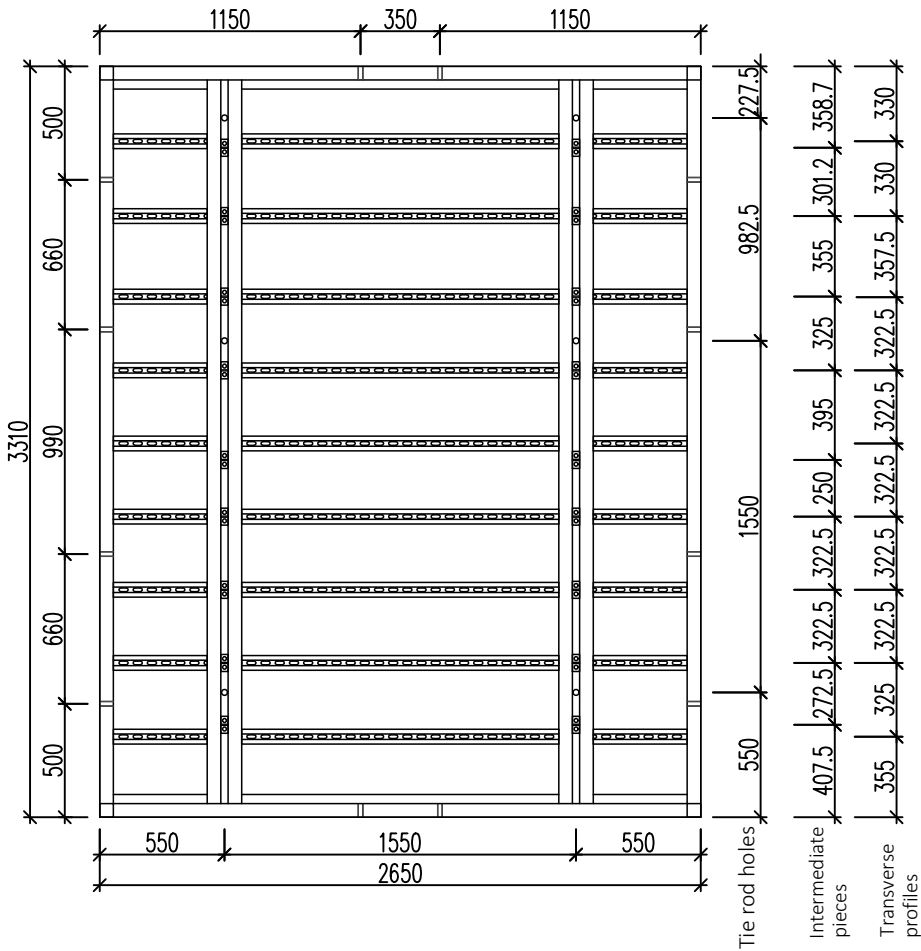

Detail of intermediate piece in integral bracing

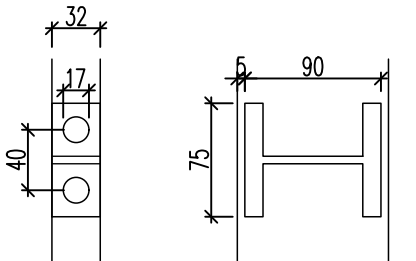

Section of integral bracing showing tie rod hole

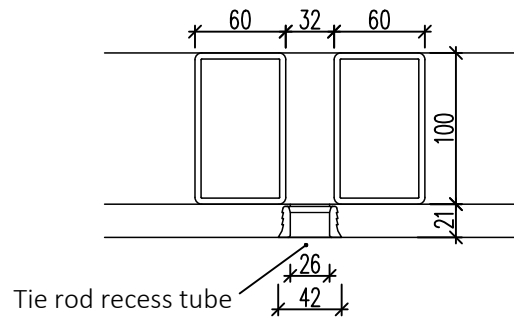



16.2 NOEtop standard panels

16.2.1 Overview of panel elements

Panel elements  
Height 3310 mm

		Panel with facing		
Width mm	Height mm	Panel area m <sup>2</sup>	Weight kg	Part No.
1325	3310	4,39	252,9	160065
1250		4,14	241,8	160066
1000		3,31	204,8	160067
750		2,48	168,1	160068
550		1,82	138,6	160070
500		1,66	131,2	160071
450		1,49	123,8	160073
400		1,32	116,4	160074
250		0,83	94,1	160075

Panel elements  
Height 2650 mm

		Panel with facing		
Width mm	Height mm	Panel area m <sup>2</sup>	Weight kg	Part No.
1325	2650	3,51	205,2	168019
1250		3,31	196,2	168109
1000		2,65	166,2	168209
750		1,99	136,3	168309
550		1,46	112,1	168609
500		1,33	106,1	168409
450		1,19	100,1	168749
400		1,06	94,1	168909
250		0,66	76,0	168509

Panel elements  
Height 1325 mm

		Panel with facing		
Width mm	Height mm	Panel area m <sup>2</sup>	Weight kg	Part No.
1325	1325	1,76	111,6	169009
1250		1,66	106,7	169109
1000		1,33	90,3	169209
750		0,99	74,1	169309
550		0,73	61,0	169609
500		0,66	57,7	169409
450		0,59	54,5	169749
400		0,53	51,2	169909
250		0,33	41,0	169509

Panel elements  
Height 660 mm

		Panel with facing		
Width mm	Height mm	Panel area m <sup>2</sup>	Weight kg	Part No.
1325	660	0,88	63,6	163019
1250		0,75	60,7	163109
1000		0,66	51,1	163209
750		0,50	41,9	163309
550		0,36	34,2	163609
500		0,33	32,3	163409
450		0,30	30,5	163749
400		0,26	28,6	163909
250		0,17	22,9	163509



# Assembly and Operating Manual

## NOEtop formwork



### 16.2.2 Elevations and sections

Elements 3310 mm high  
Width 250-1325 mm

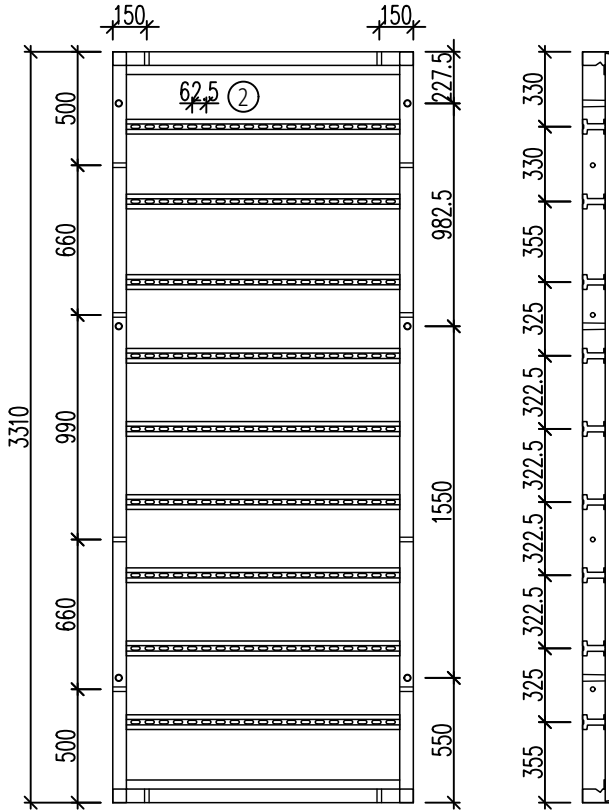

Section

Elements 2650 mm high  
Width 250-1325 mm

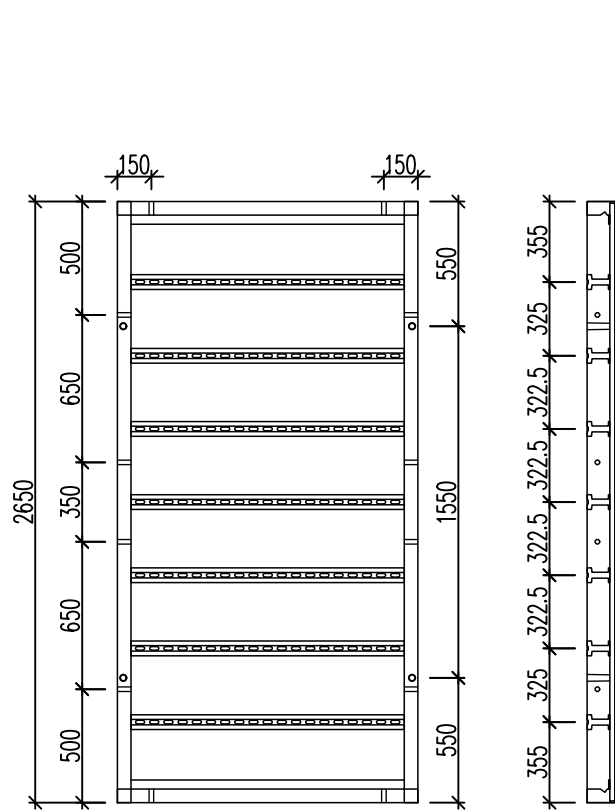

Section

Elements 1325 mm high  
Width 250-1325 mm

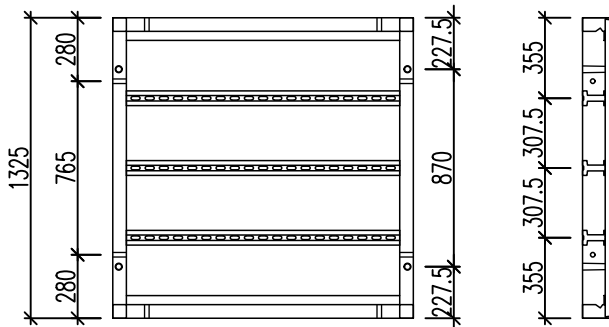

Section

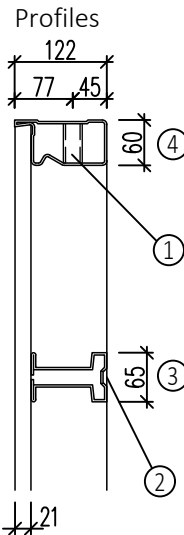

Detail of tie rod hole

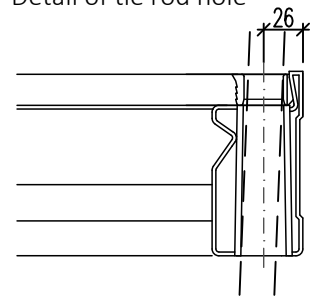

Skewed tie rod  
For  $\phi 20$  max. 2.2° (equiv. 38 mm/m)  
For  $\phi 15$  max. 5.1° (equiv. 89 mm/m)

Elements 660 mm high  
Width 250-1325 mm

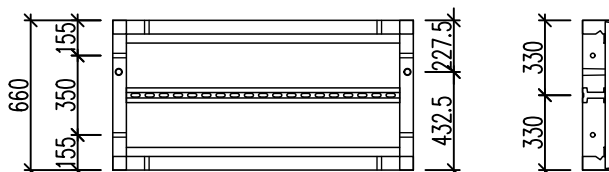

Section

- 1  $\phi 19$
- 2 LL18/40
- 3 Hat profile
- 4 Edge profile

16.3 NOEtop multifunction panel MFP

NOEtop MFP 1325x3310 mm  
Part No. 168022 Weight 334 kg

Section

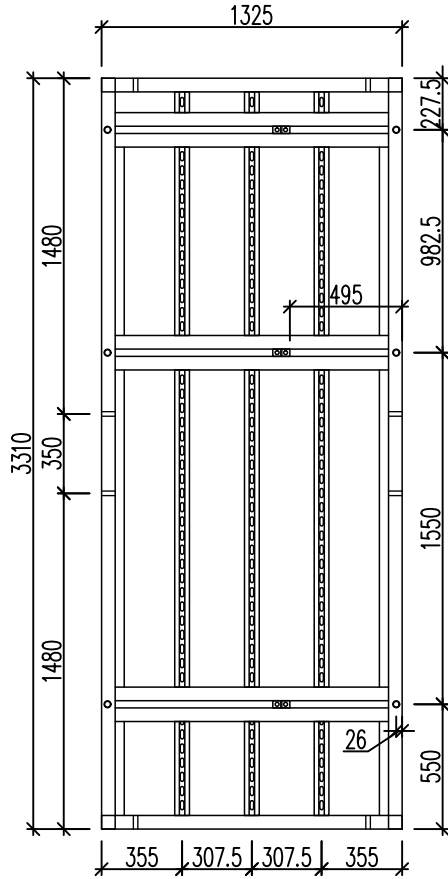

NOEtop MFP 1325x2650 mm  
Part No. 168020 Weight 260 kg

Section

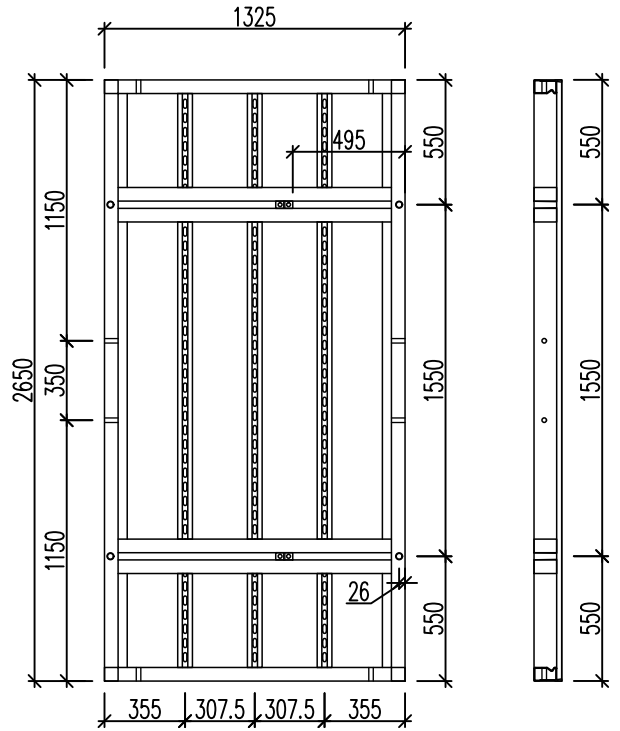

NOEtop MFP 1325x1325 mm  
Part No. 168021 Weight 190 kg

Section

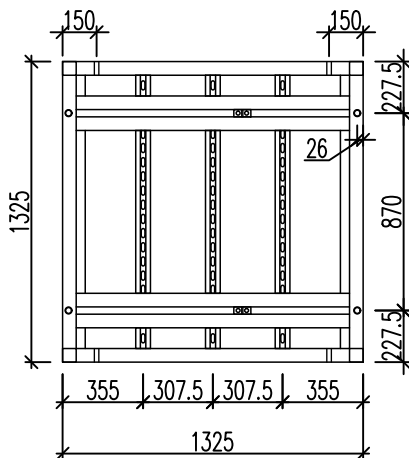

16.4 NOEtop EC panel ECP

NOEtop ECP 1000x3310 mm

Part No. 160076

Weight 267 kg

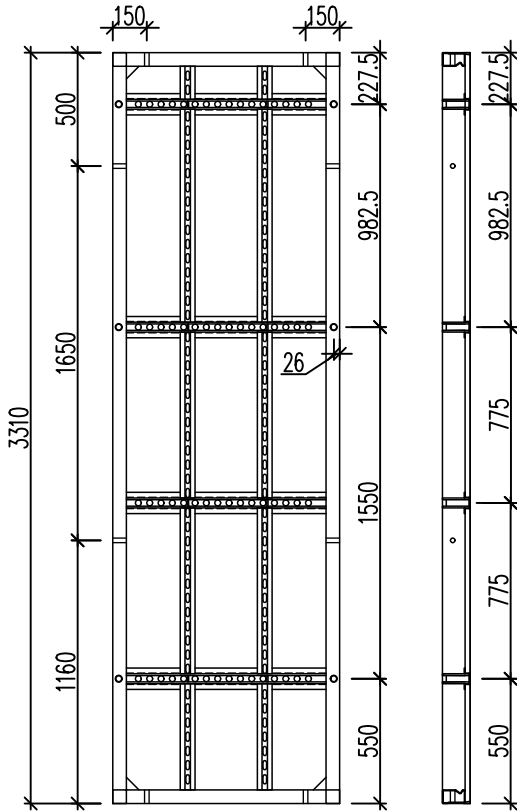

NOEtop ECP 1000x2650 mm

Part No. 167009

Weight 214 kg

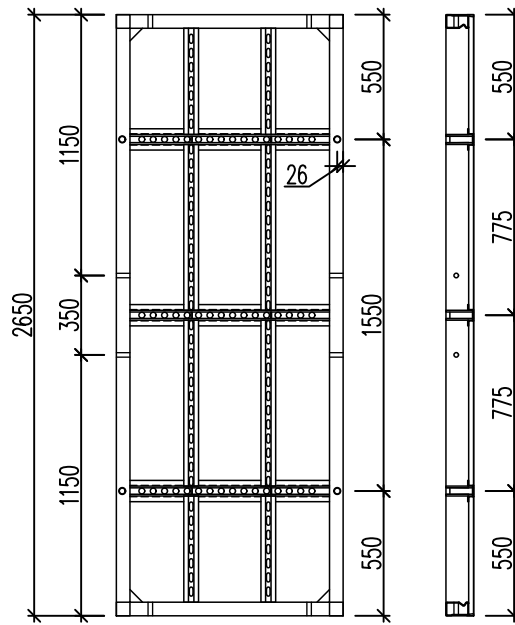

Dimensions of holes through channel

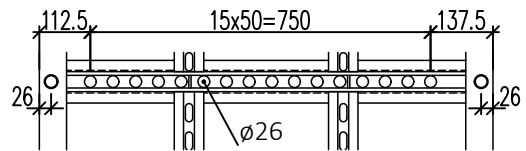

NOEtop ECP 1000x1325 mm

Part No. 167019

Weight 105 kg

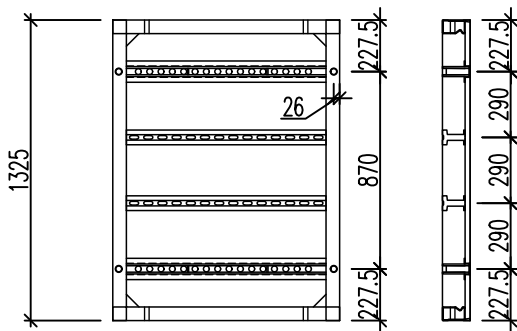

NOEtop ECP 1000x660 mm

Part No. 163009

Weight 55 kg

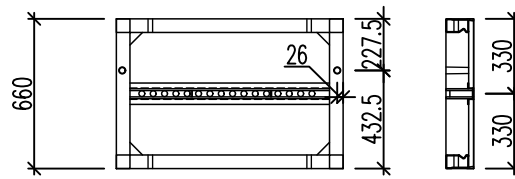

# NOEtop formwork



## 16.5 NOEtop internal corner IC 250x250 mm

3310 mm high

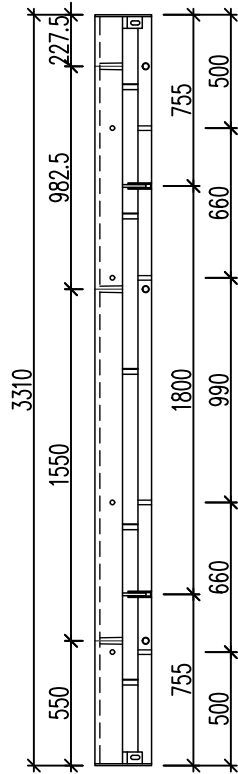

2650 mm high

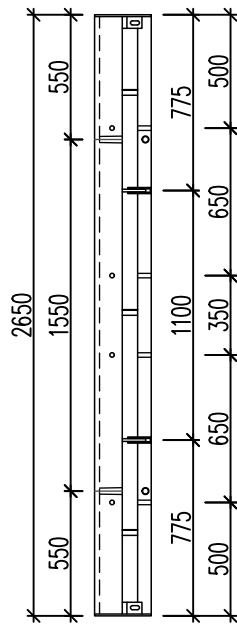

1325 mm high

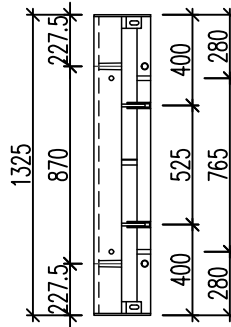

660 mm high

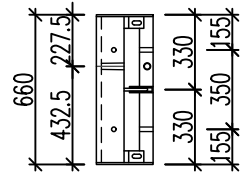

Section

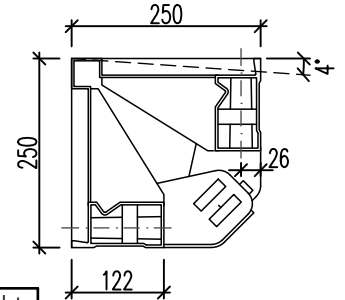

Height [mm]	Part No.	Area [m <sup>2</sup> ]	Weight [kg]
3310	160078	1.65	101
2650	167209	1.33	83.3
1325	167219	0.66	51.2
660	167249	0.33	31.1

The internal corner formwork can be folded in on itself by up to 4° for stripping.

## 16.6 NOEtop external corner angle ECA

### 16.6.1 ECA steel

3310 mm 2650 mm 1325 mm 660 mm

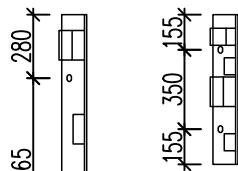
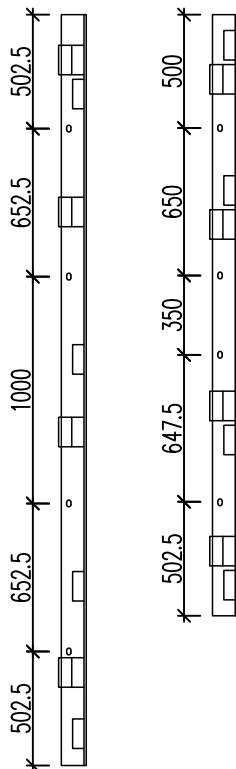

Cross-section

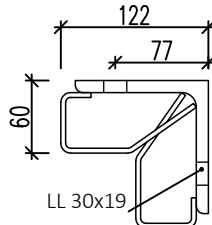

Height [mm]	Part No.	Weight [kg]
3310	164045	61,0
2650	164044	50,1
1325	164043	25,1
660	164042	13,0

### 16.6.2 ECA Alu

3310 mm 2650 mm 1325 mm 660 mm

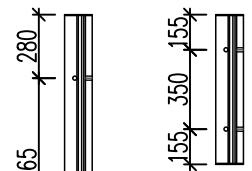
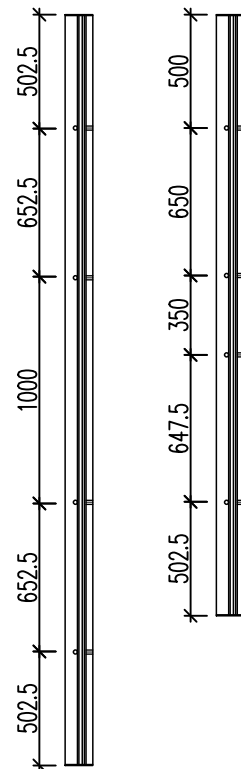

Cross-section

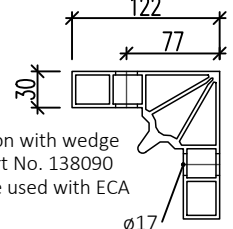

Connection with wedge clamp Part No. 138090 cannot be used with ECA ALU!

Height [mm]	Part No.	Weight [kg]
3310	164065	25,3
2650	164064	16,9
1325	164063	8,4
660	164061	4,2

16.7 Adjustable external corner 60°-180° with NOEplast channel

3310 mm high

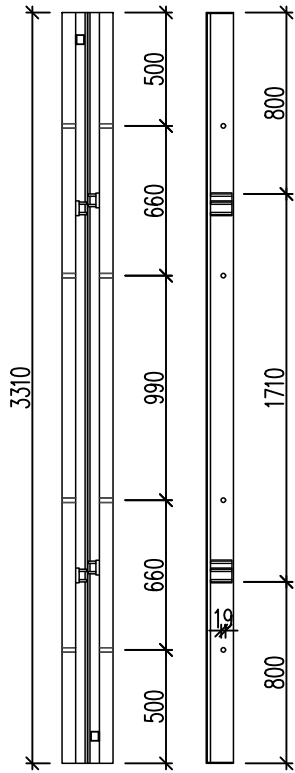

2650 mm high

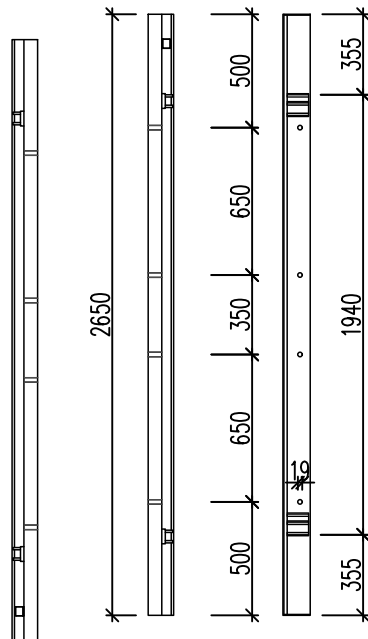

Height [mm]	Part No.	Area [m <sup>2</sup> ]	Weight [kg]
3310	164008	0,74	100,0
2650	164007	0,60	80,8
1325	164006	0,30	44,5
660	164005	0,15	22,8

Section

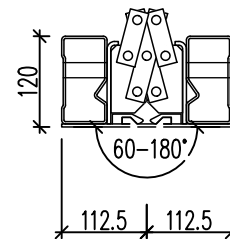

1325 mm high

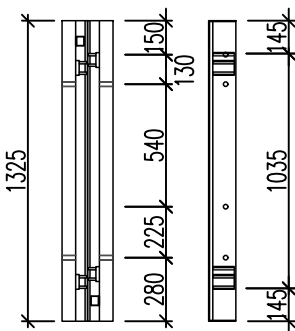

660 mm high

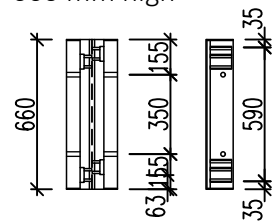

16.8 Adjustable internal corner 60°-180° with NOEplast channel

3310 mm high

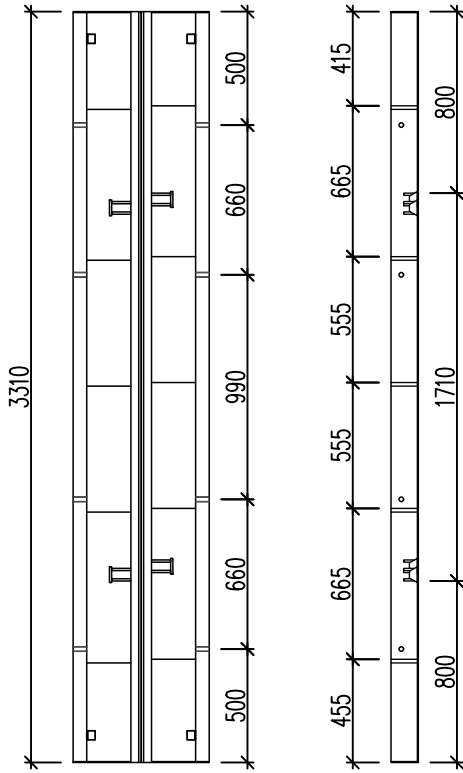

1325 mm high

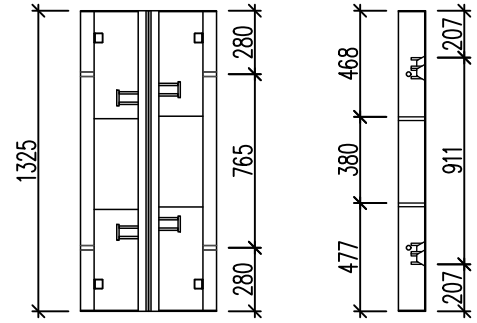

660 mm high

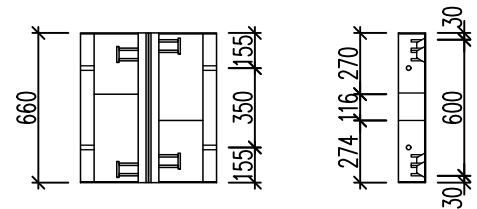

Height [mm]	Part No.	Area [m <sup>2</sup> ]	Weight [kg]
3310	164003	1,99	140,1
2650	164002	1,59	114,0
1325	164001	0,8	63,3
660	164000	0,4	33,6

2650 mm high

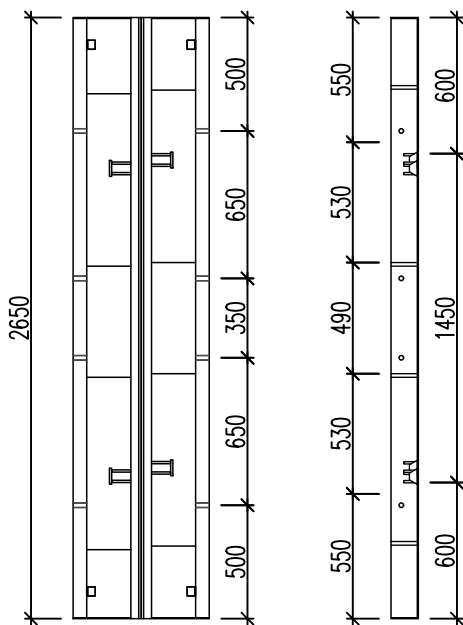

Section

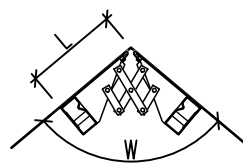
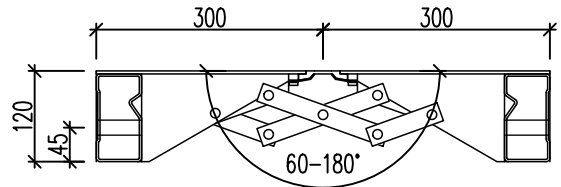

Angle	Length L [mm]
180	300
150	302
135	303
120	304
100	307
90	309
80	313
70	317
60	325

16.9 Compensation steel sheet

3310 mm high

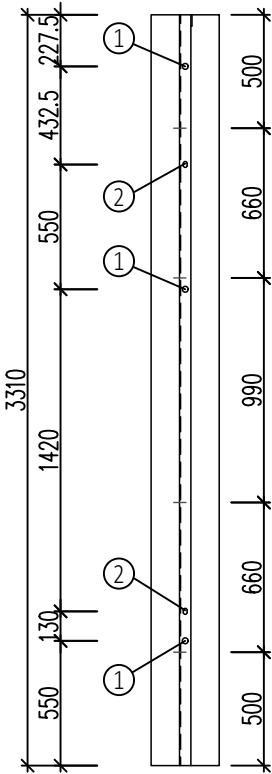

2650 mm high

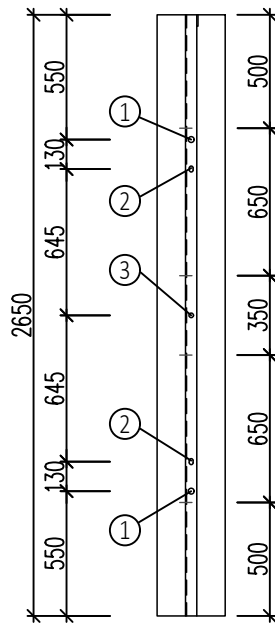

1325 mm high

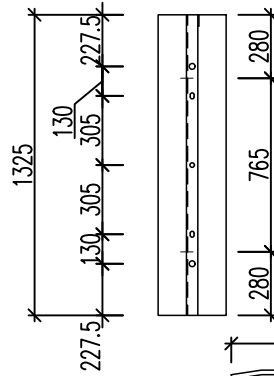

660 mm high

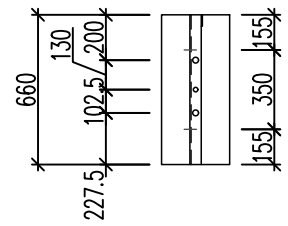

Plan

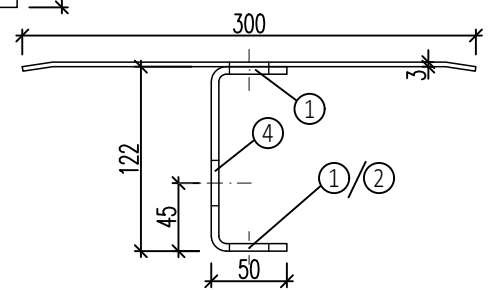

- 1  $\varnothing 26$
- 2 LL17/26
- 3  $\varnothing 20$  middle
- 4  $\varnothing 30$

Height [mm]	Part No.	Area [m <sup>2</sup> ]	Weight [kg]
3310	130096	1.0	50,2
2650	137549	0.8	41,7
1325	137559	0.4	20,5
660	137569	0.2	10,3

16.10 Filler piece

3310 mm high

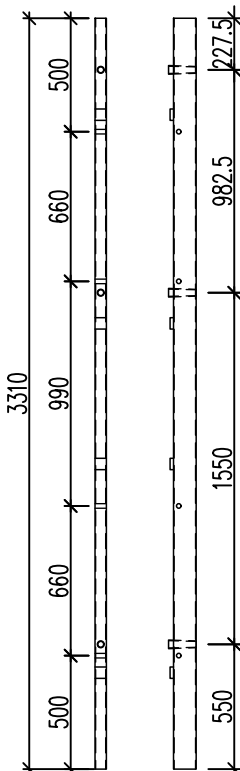

2650 mm high

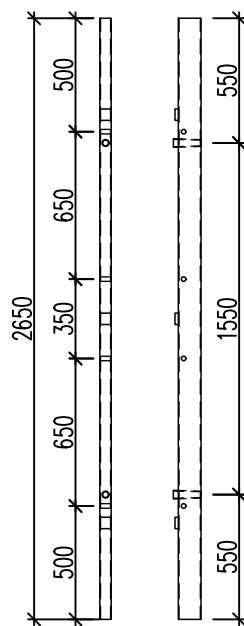

1325 mm high

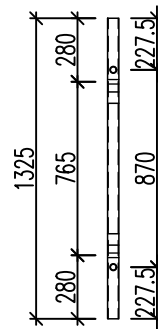

660 mm high

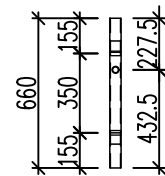

Plan

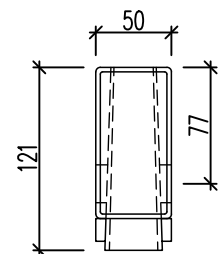

Height [mm]	Part No.	Weight [kg]
3310	130095	23,9
2650	137309	19,1
1325	137319	9,8
660	137329	5,4

# NOEtop formwork



## 16.11 NOEtop stripping corner 300x300 mm

Stripping clearance approx. 20 mm each side

Height [mm]	Part No.	Area [m <sup>2</sup> ]	Weight [kg]
3310	137768	1,99	209,5
3000	137764	1,80	183,0
2650	137762	1,59	175,0
1325	137761	0,80	87,5

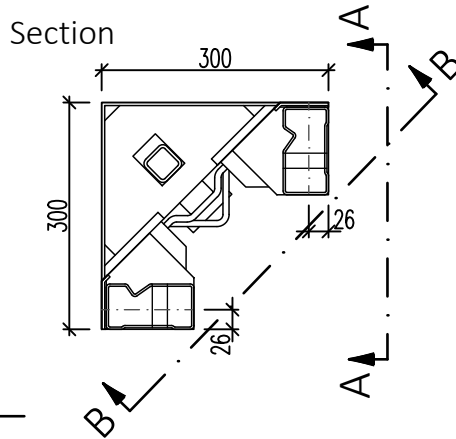
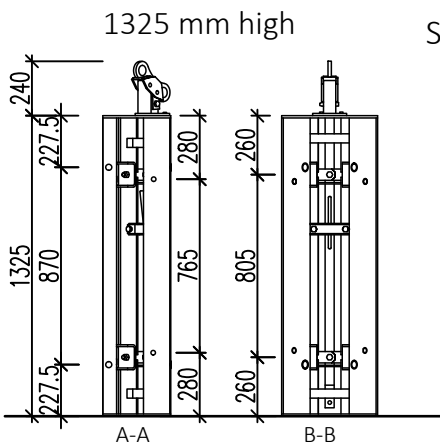
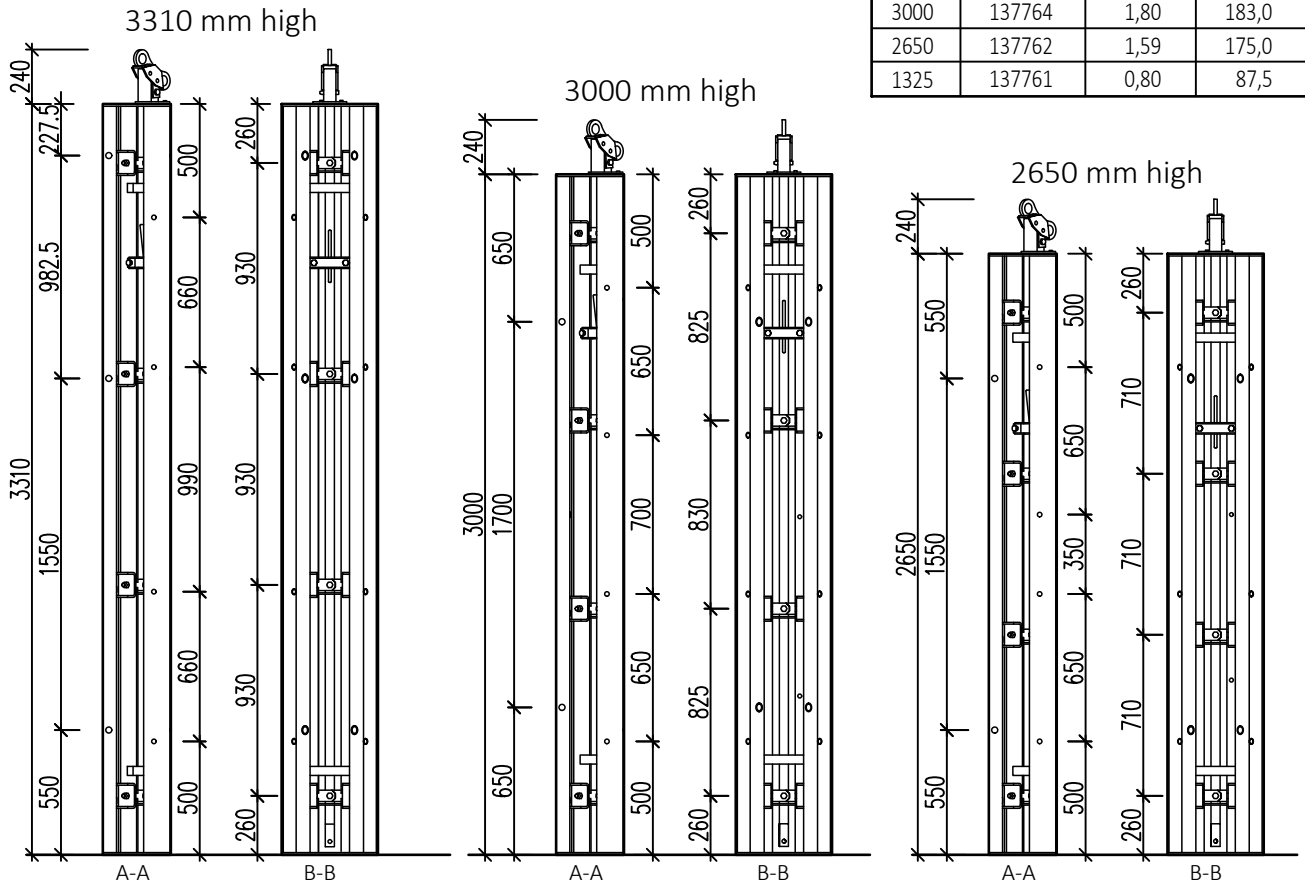

Lever f. NOEtop stripping corner

Part No. 398202  
Weight 3.9 kg

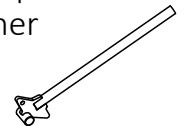

M18x160 bolt

Part No. 318900

M16x40 bolt

Part No. 313400

## 16.12 Profiled timber filler piece and timber filler piece

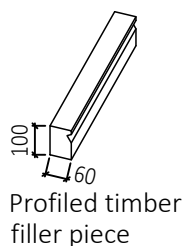

Height [mm]	Part No.	Area [m <sup>2</sup> ]	Weight [kg]
3310	On req.	0,20	10,8
2650	137334	0,16	8,6
1325	137335	0,08	4,3
660	137336	0,04	2,2

Timber filler piece

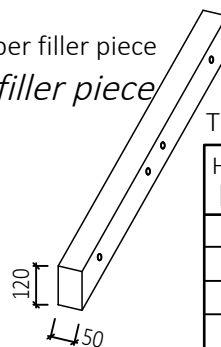

For use as filler piece at panel butt joints or at working joints.

Transverse holes like NOEtop profile

Height [mm]	Part No.	Area [m <sup>2</sup> ]	Weight [kg]
3310	On req.	0,17	10,8
2650	137331	0,13	8,6
1325	137332	0,07	4,3
660	137333	0,04	2,2



16.13 NOEtop Alu panel

2650 mm high  
Width 250-883 mm

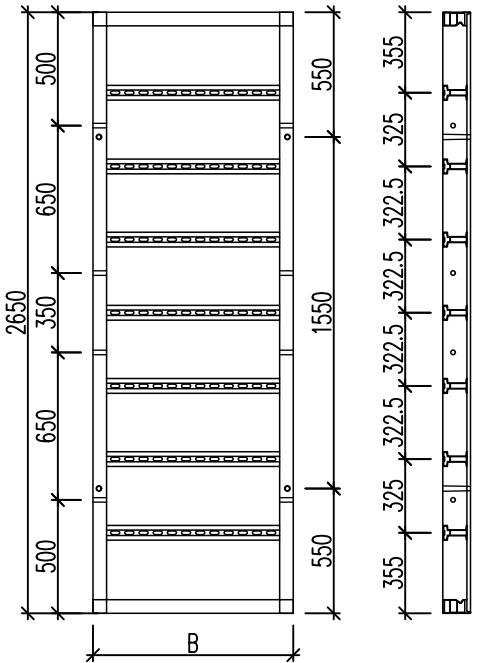

1325 mm high  
Width 883 mm

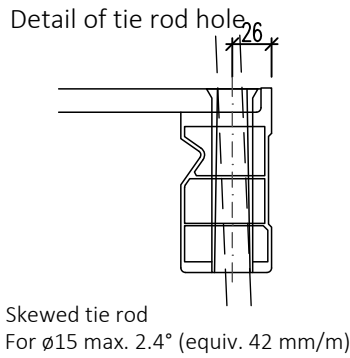
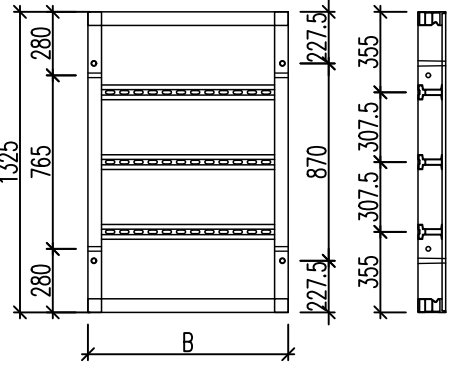
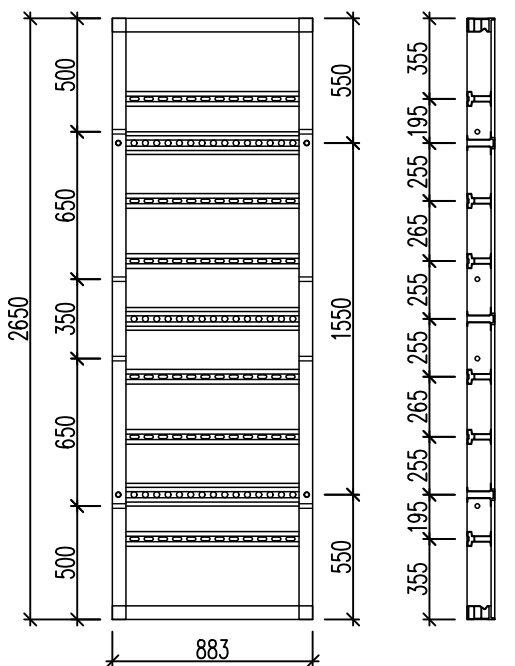

Table of panels

Part No.	Width mm	weight kg
Height 2650 mm		
467681	900	65
167322	883	64
167324	750	57
167326	550	46
167328	500	44
167330	450	42
167336	250	31
Height 1325 mm		
167340	883	34
167382	750	31
167384	550	25
167385	500	23
167387	450	22
167389	250	16

16.14 NOEtop Alu EC panel ECP

EC panel Alu 2650 mm high  
Part No. 167363  
Weight 70.7 kg



EC panel Alu 1325 mm high  
Part No. 167366  
Weight 36,5 kg

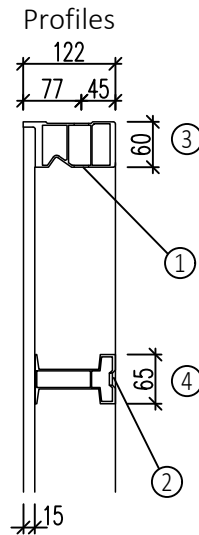
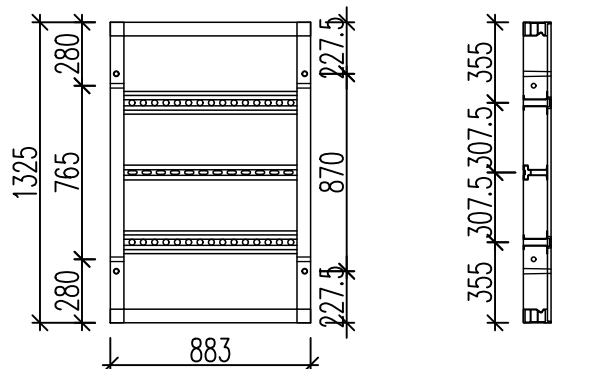

- 1  $\phi 19$
- 2 LL18/40
- 3 Hat profile
- 4 Edge profile

## 16.15 Connections

### NOE Toplock

For panel connections and longitudinal compensations up to 42 mm

Part No. 137976

Weight 3.7 kg

Perm. Tension force 15 kN

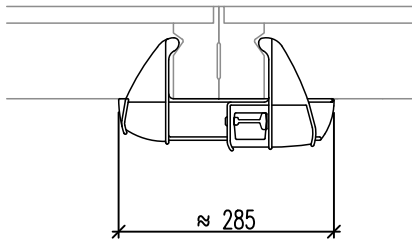

### NOE Toplock X

For panel connections and longitudinal compensations up to 100 mm

Part No. 137960

Weight 4.3 kg

Perm. Tension force 20 kN

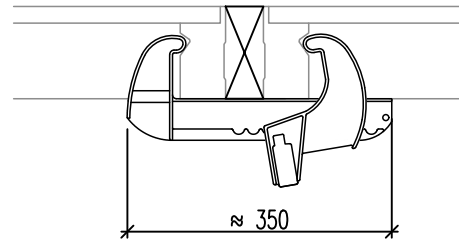

### Multi-claw

For corner connections, stop-ends, tying

Part No. 164030

Weight 3.7 kg

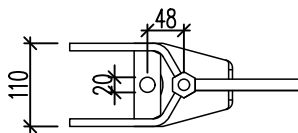
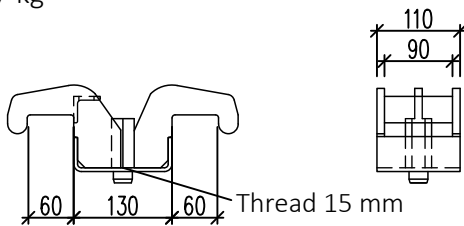

For panel connections and longitudinal compensations up to 100 mm can also be used Toplock H, part no. 137970, instead of Toplock X.

### Alignment clamp

For extensions of end-on and side-on panels

Part No. 135309

Weight 19.9 kg

Elevation A : Extensions of end-on panels

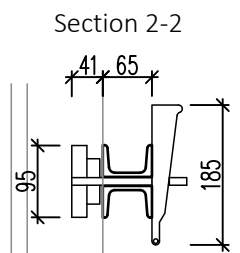
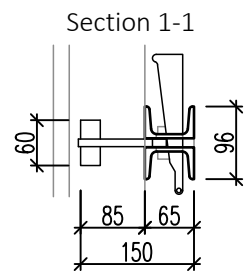
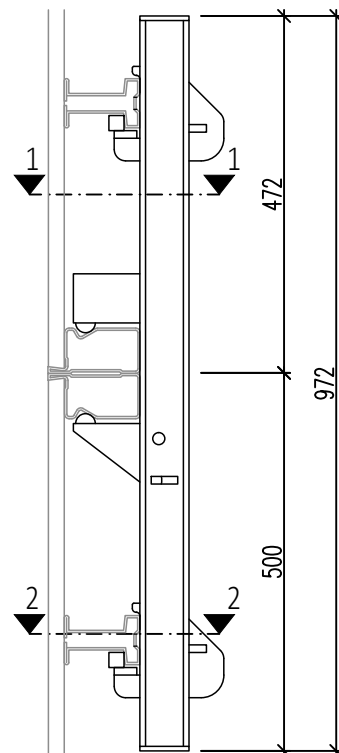

### Extension clamp

For extending panels by 200 mm

Part No. 137850

Weight 3.2 kg

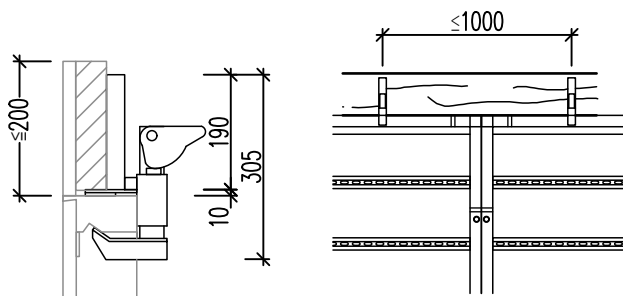

# NOEtop formwork

## 16.16 Tie rod fittings

Tie rod  $\varnothing$  20 mm (Perm. tension force in acc. with DIN 18216: 160 kN)

### Tying nut

Part No. 680009  
Weight 0.4 kg

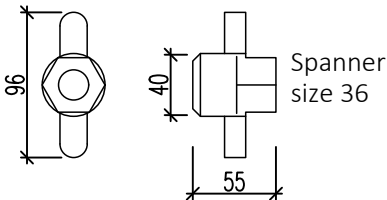

### Waling plate

Part No. 691509  
Weight 0.7 kg

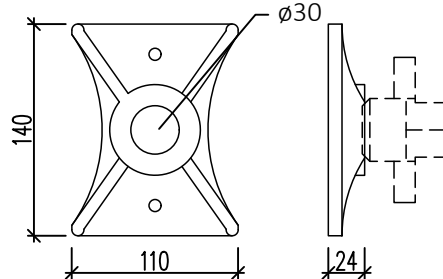

### Wing nut with swivel plate

Part No. 691600  
Weight 1.0 kg

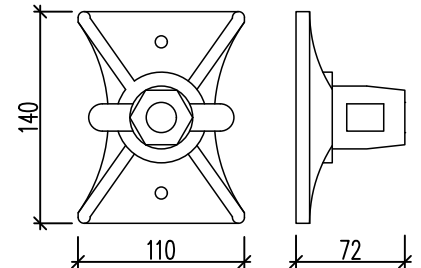

### Tie rod $\varnothing$ 20

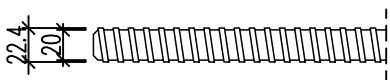

Length 950 mm Part No. 670959 Weight 2.4 kg

Length 1250 mm Part No. 671259 Weight 3.2 kg

Tie rod  $\varnothing$  15 mm (Perm. tension force in acc. with DIN 18216: 91 kN)

### Sprint nut

Part No. 680580  
Weight 0.7 kg

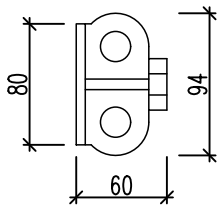

### Hexagonal nut

Part No. 680900  
Weight 0.13 kg

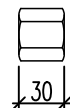

Part No. 681000  
Weight 0.26 kg

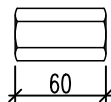

### Wing nut with swivel plate

Part No. 691700  
Weight 1.0 kg

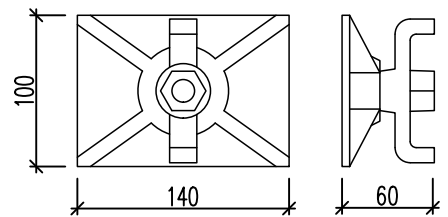

### Waling plate

Part No. 691400  
Weight 0.9 kg

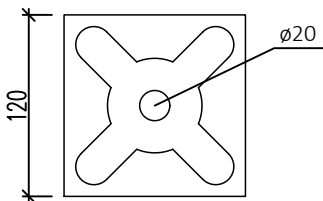

### Top waling plate

Part No. 691500  
Weight 0.6 kg

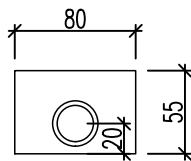

For tying against existing walls or for side-on panels.

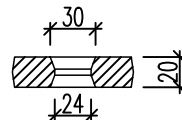

### Tie rod $\varnothing$ 15

Part No. 67 . . . . .  
Weight 1.4 kg/m

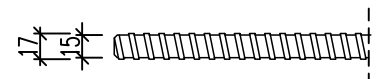

### Lost tie $\varnothing$ 15 mm

Waved anchor  
 $\varnothing$ 15  
550 mm long  
Z = 90 kN/Rod  
Part No. 542007

Anchor  $\varnothing$ 15  
Z = 90 kN/rod  
Part No. 542005

Min. concrete compressive strength for Perm. tension loading: 25 MN/m<sup>2</sup>

Anchor  $\varnothing$ 15 Z = 90 kN/rod  
Part No. 542006

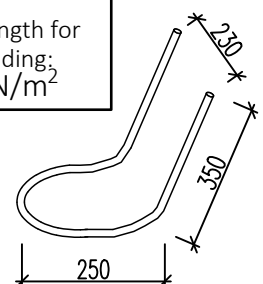

# NOEtop formwork



## 16.17 Bracing and hammer-head bolts

Compensation channel  
For filler piece up to 250 mm

Part No. 135109

Weight 9.6 kg

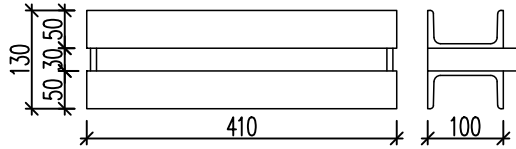

Extension channel

Part No. 135208

Weight 15.9 kg

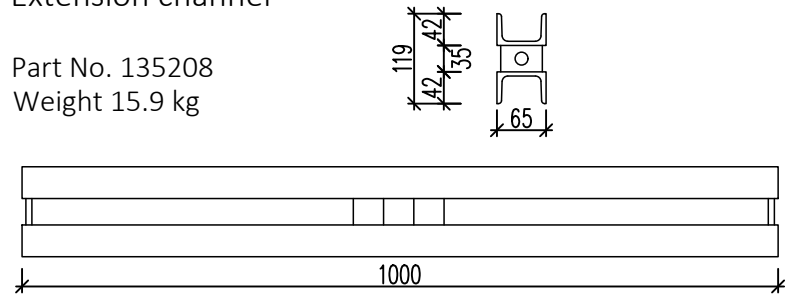

Alignment channel  
For stopend forms and aligning panels

Part No. 135210

Weight 21.5 kg

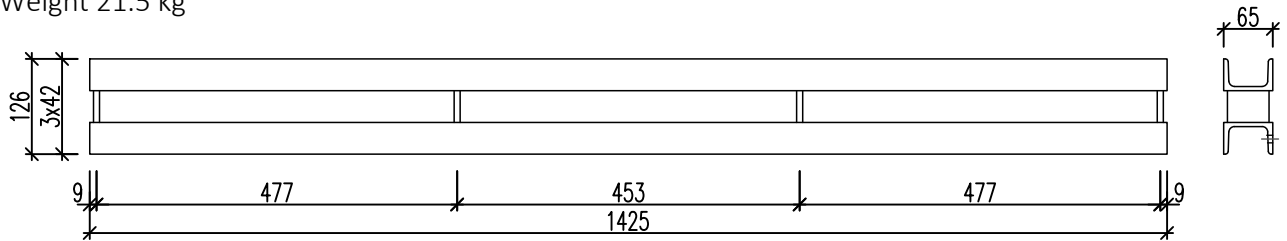

NOEtop bracing 2640-32 mm

Part No. 541024

Weight 74 kg

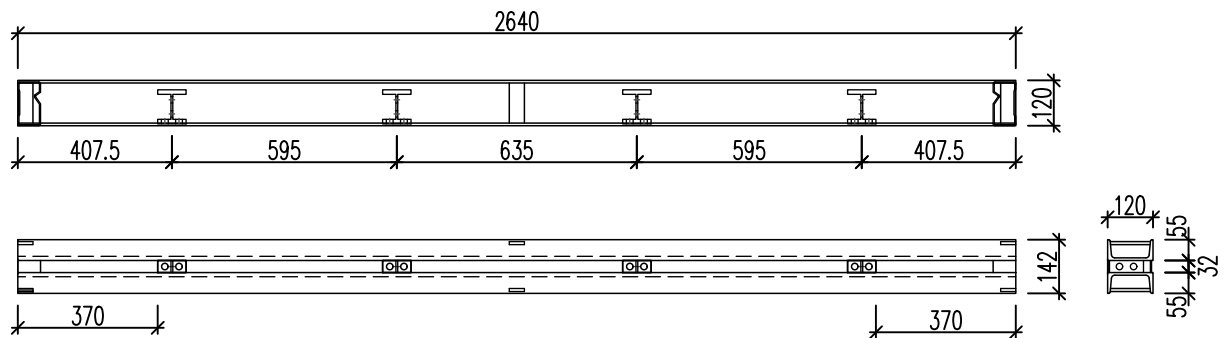

NOEtop bracing 3300-32 mm

Part No. 541025

Weight 92 kg

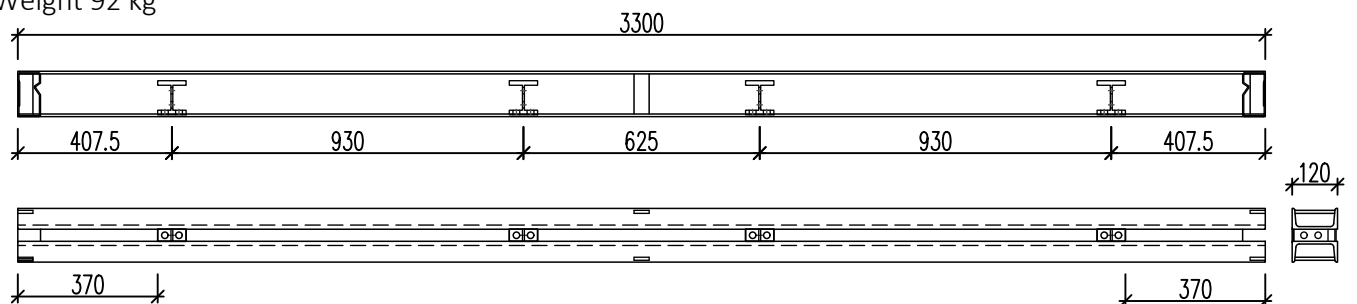

For complementary bracings with a distance of bracing of 40 mm (part no. 541034 or part no. 541035), there are bore holes for fixing the bottom support for the NOEtop Support Bracket.

Hammer-head bolt with handle and integral nut

Part No. 319338  
 KL ≤ 125 mm  
 Weight 1.1 kg

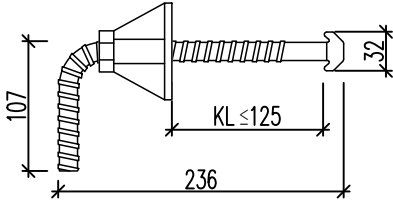

Part No. 319339  
 KL ≤ 205 mm  
 Weight 1.2 kg

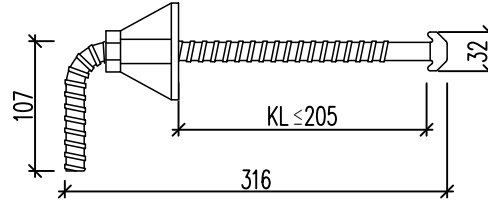

Connection screw

Part No. 135019  
 Weight 0.6 kg

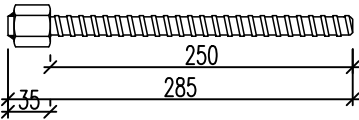

Thread 15 mm with hexagonal nut  
 30 mm e.g. for EC panels and  
 corner hinges

Stop-end holder 15 kN

Part No. 164032  
 Weight 0.7 kg

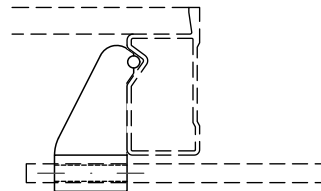

Stop-end holder 25 kN

Part No. 164036  
 Weight 2,1 kg

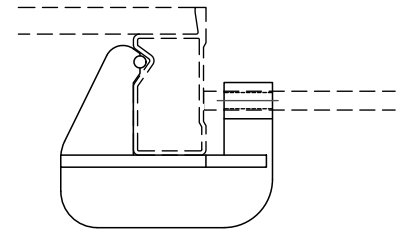

Hexagonal bolt M18x160

Part No. 318900  
 Weight 0.5 kg  
 For bolting to edge profiles

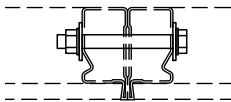

Hexagonal bolt M18x100

Part No. 318801  
 Weight 0.36 kg

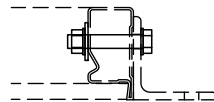

16.18 Transport equipment

Lifting pin

Permissible load Z = 0.5 t or 5 kN  
 Part No. 136808  
 Weight 0.7 kg

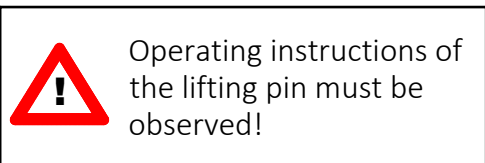
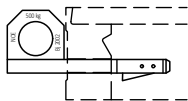

Crane hook

Part No. 135905  
 Weight 6.8 kg

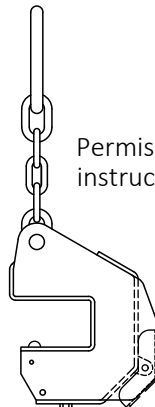

Permissible load see operating  
 instructions or 15.1.4

Use permitted only in accordance  
 with the operating instructions !

NOE quadruple

Transport hanger

Permissible load 2 t or 20 kN  
 Part No. 922910  
 Weight 13 kg

16.19 Foundation tying equipment

Tying claw

Part No. 137500  
Weight 1.7 kg

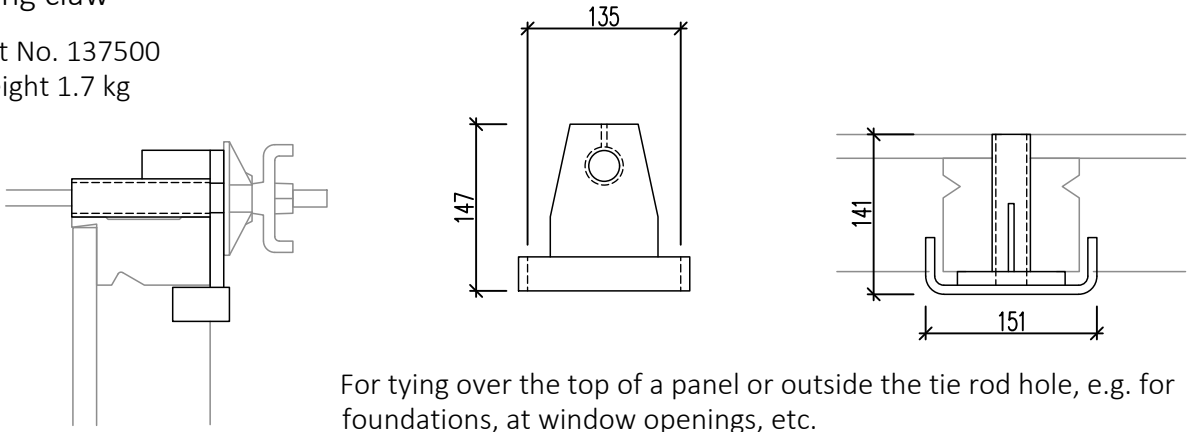

For tying over the top of a panel or outside the tie rod hole, e.g. for foundations, at window openings, etc.

NOEtop Foundation clamp

Part No. 137297  
Weight 1.5 kg

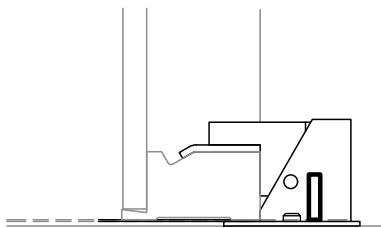

For strip-steel stressing devices for foundation panels.

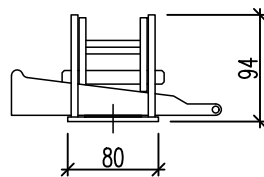

Strip-steel stressing device

Part No. 108031  
Weight 24 kg  
Cut to length at a hole centre!

Holes 50 mm c/c

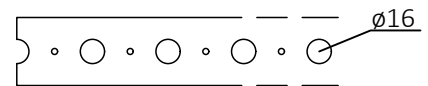

Supplied in 50 m rolls.  
Permissible tension force 12 kN.

16.20 Scaffolds and accessories

Part No. 552204  
Weight 12,4 kg

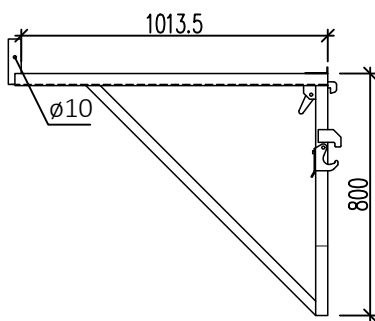

Part No. 111400  
Weight 4,0 kg

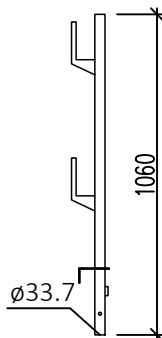

Handrail tube  
Part No. 111403  
Weight 5,0 kg

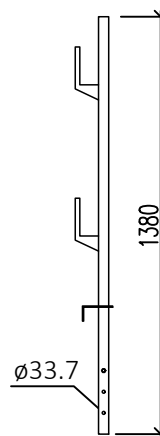

NOEtop clamp support handrail tube  
Part No. 552214  
Weight 3.1 kg

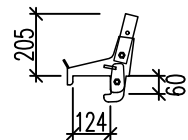

Plug 9 mm  
for use with handrail tube  
Part No. 890834

Plastic plugs

(pack = 250 No.)

Part No.	Shape	Colour	Use
693409	With domed head	White	For tie rod holes NOEtop ø30 mm
693900		White	For tie rod holes NOEtop Alu ø23 mm
693600		Light grey	for EC panel ø25 mm

# NOEtop formwork

## Hinged scaffold 2650 mm

Part No. 552210 Weight 171 kg

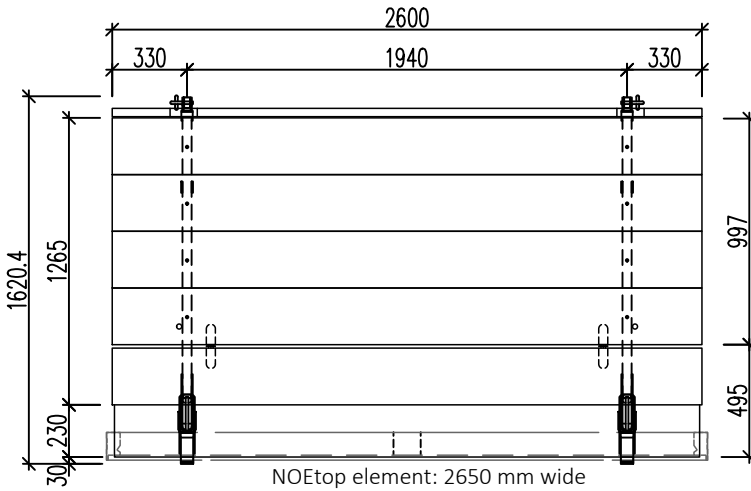

## Section through attached scaffold

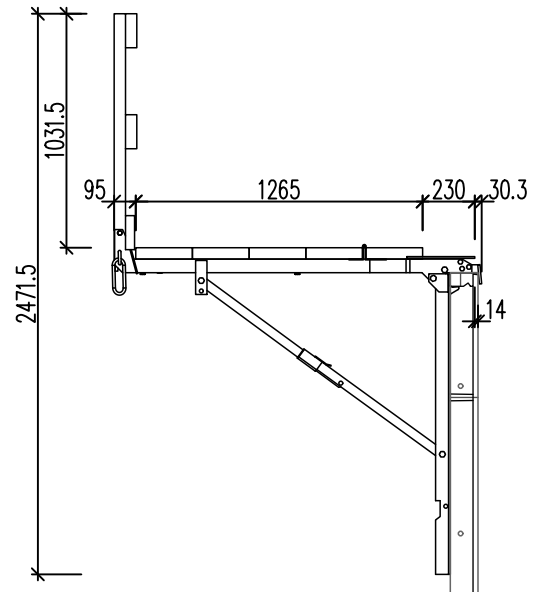

## Hinged scaffold 1325 mm

Part No. 552211 Weight 112 kg

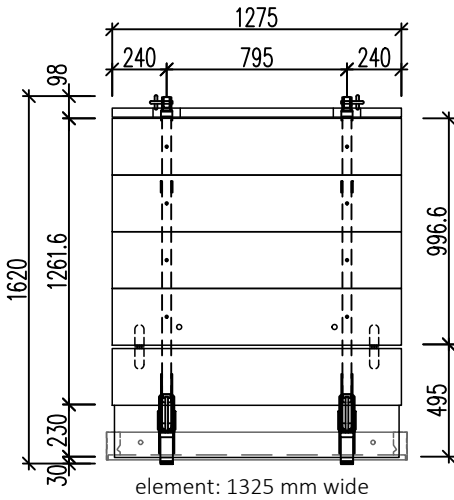

## Section through folded scaffold

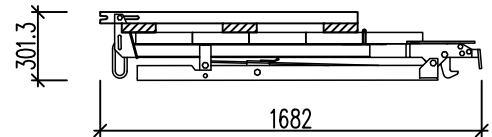

## Hinged concreting scaffold 2650 mm with hatch

Part No 552212 Weight 250.3 kg

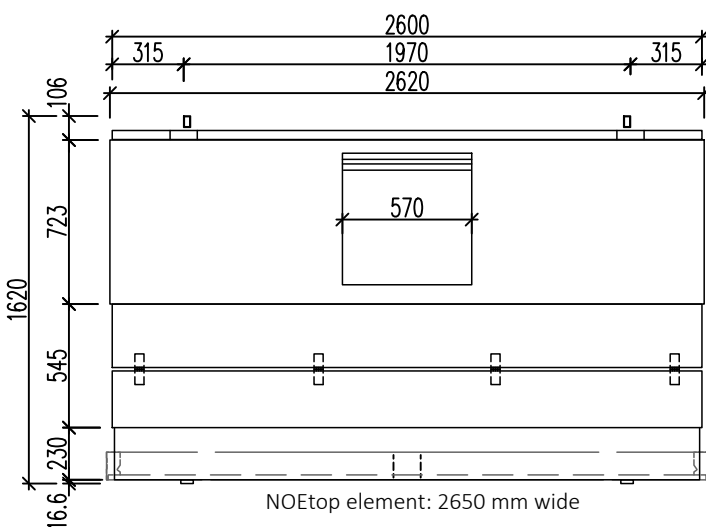

## Section through attached scaffold

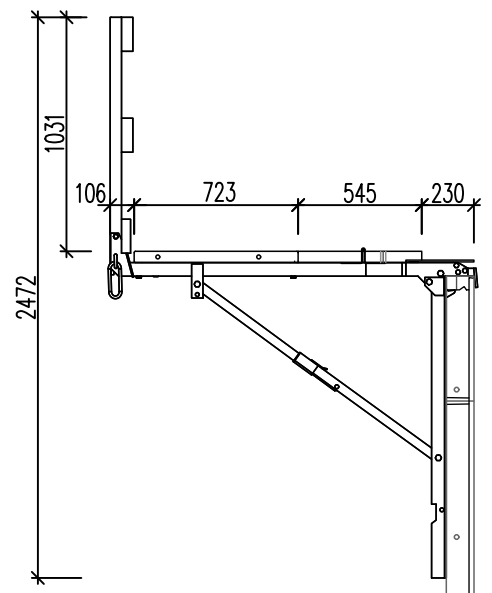

# NOEtop formwork



Concr. scaffold front guard-rail

Part No. 552218

Weight 18,3 kg

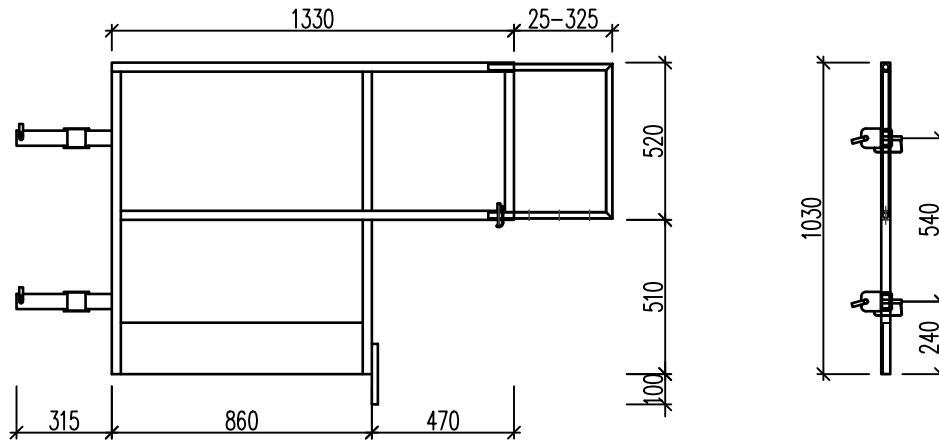

## Attaching the front guard-rail to the scaffold

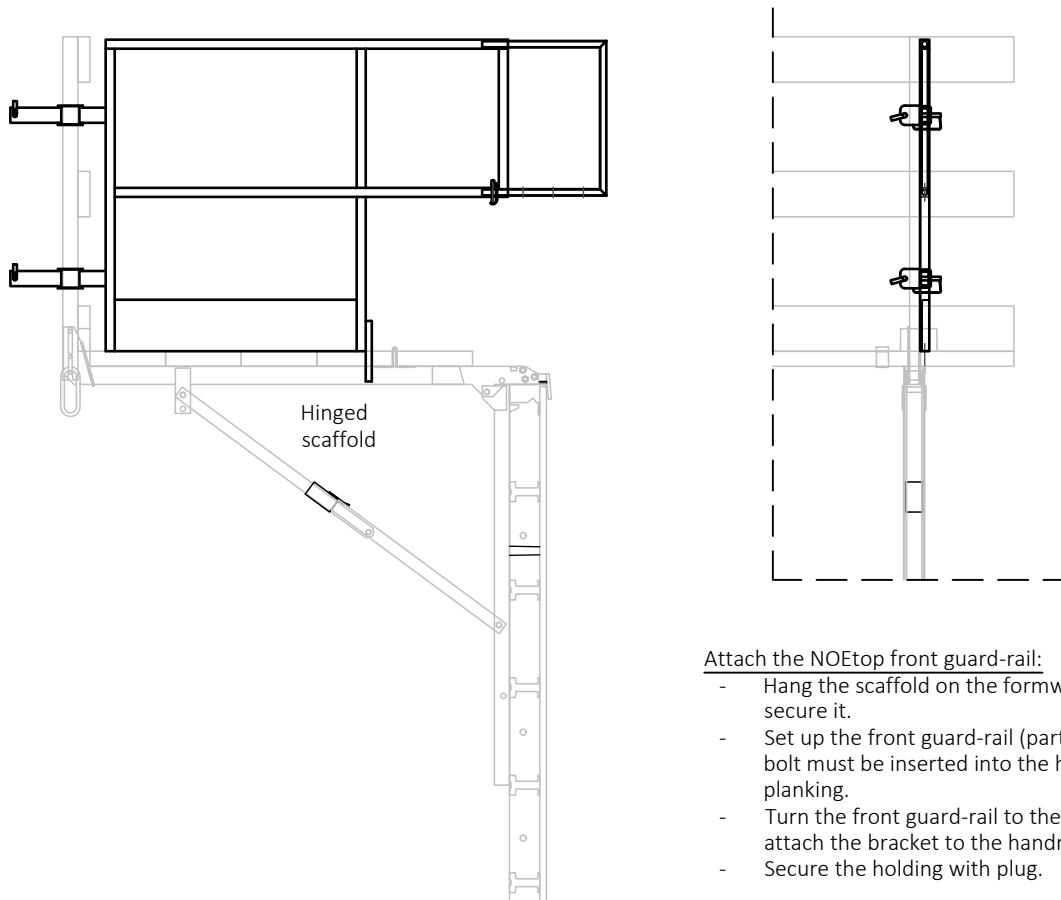

### Attach the NOEtop front guard-rail:

- Hang the scaffold on the formwork, open it and secure it.
- Set up the front guard-rail (part no 552218), the bolt must be inserted into the hole of the planking.
- Turn the front guard-rail to the handrail tube and attach the bracket to the handrail tube.
- Secure the holding with plug.



# NOEtop formwork

NOEtop concreting scaffold steel 2650 mm  
 Part No. 552241 Weight 173 kg

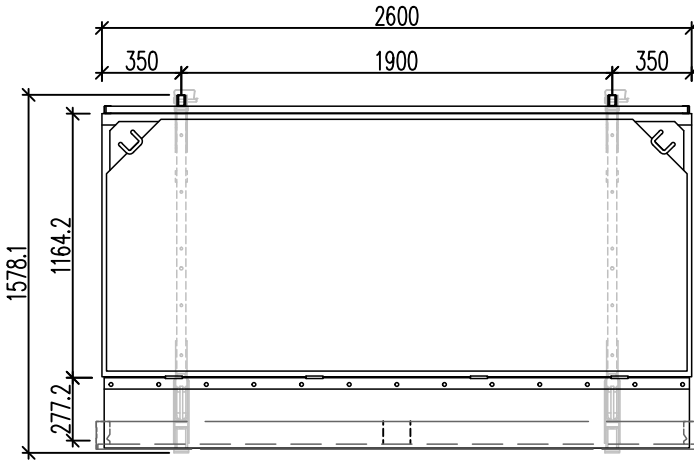

Section through attached scaffold

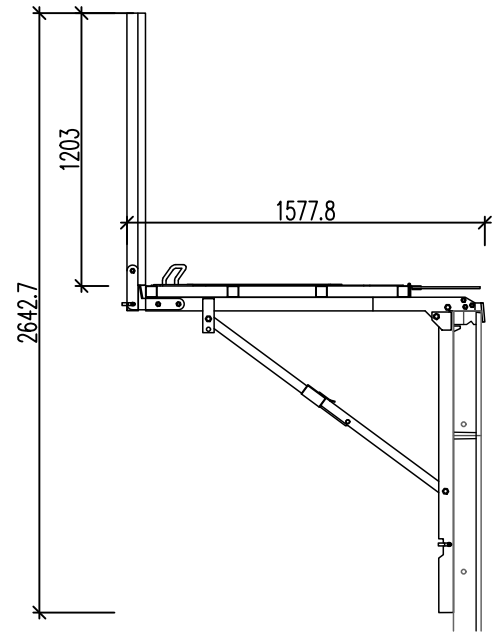

NOEtop concreting scaffold steel 1325 mm  
 Part No. 552243 Weight 134 kg

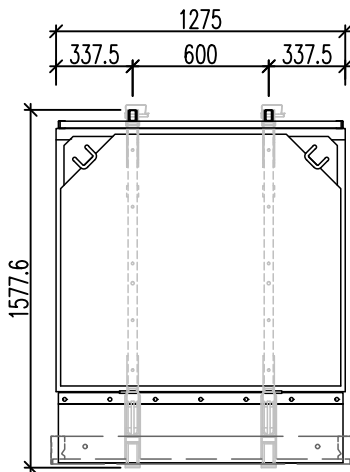

Section through folded scaffold

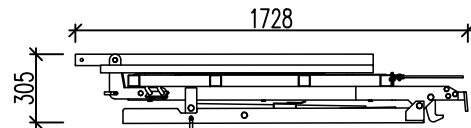

NOEtop concreting scaffold steel 2650 mm with hatch  
 Part No. 552240 Weight 184 kg

NOEtop concreting scaffold acier left and right  
 Part No. 552267 Weight 134 kg

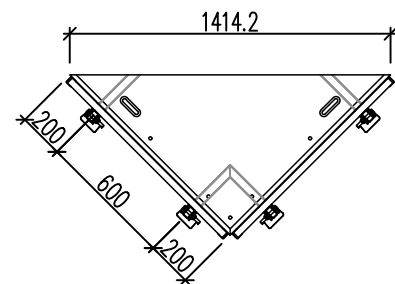
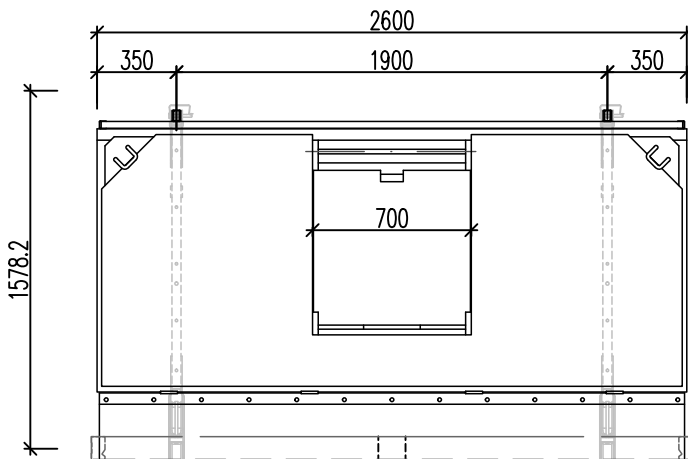

# NOEtop formwork

## NOEtop scaffold platform 2600 mm without hatch

Part No. 550014

Weight 58,4 kg

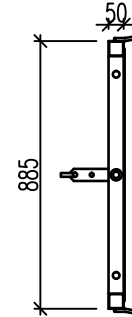
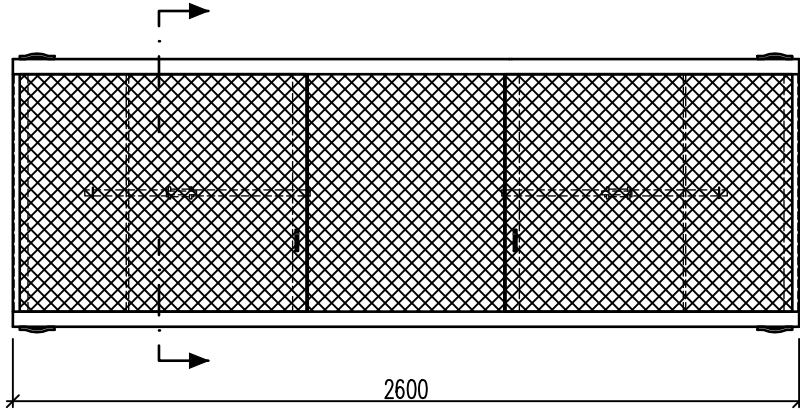

## NOEtop scaffold platform 2600 mm with hatch

Part no. 550010

Weight 67,4 kg

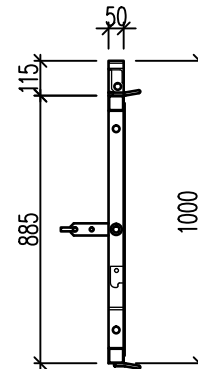
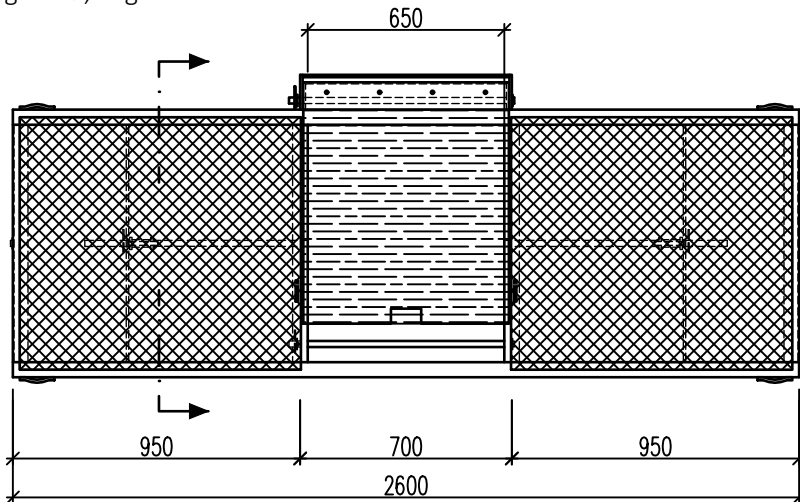

## NOEtop scaffold platform 1300 mm with hatch

Part No. 550012

Weight 47,3 kg

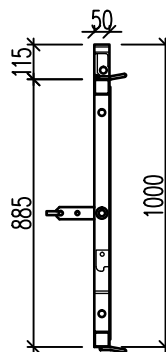
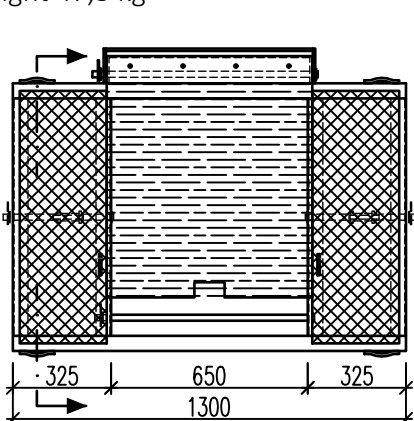

## Guardrail clamp

Part No. 900052

Weight 14 kg

a = 30-825 mm

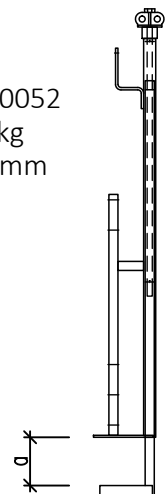

# Assembly and Operating Manual

## NOEtop formwork



### NOEtop front guard-rail

Part no 552216  
Weight 14,5 kg

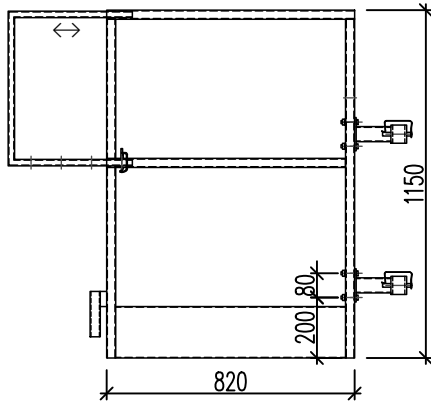

### NOEtop adjustment front guard-rail

Part no 552217  
Weight 1,7 kg

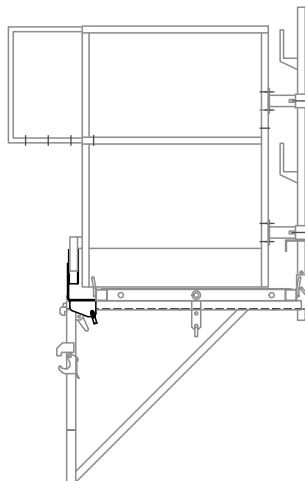
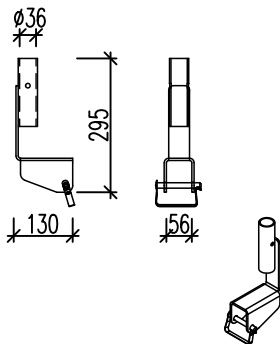

Front guard-rail attached to the walkway bracket and handrail tube.

### Rail post holder NOEtop

Part no 550025  
Weight 1,0 kg

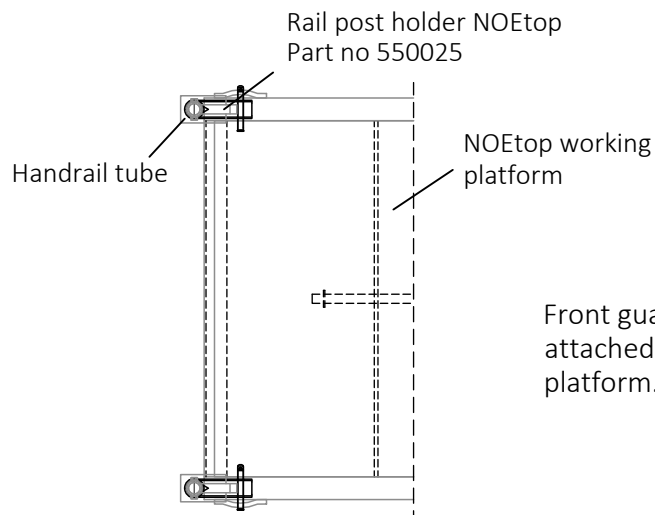
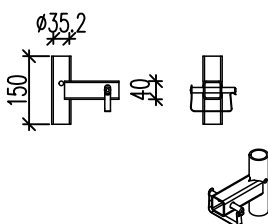

Front guard-rail attached to the working platform.

# NOEtop formwork



## NOE LSS Ladder

LSS Ladder 2975-11  
Part No. 126760

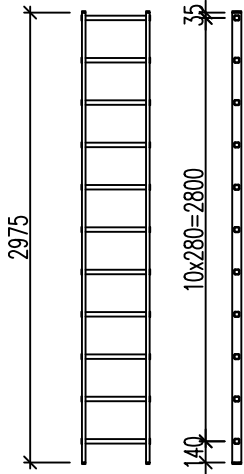

LSS Ladder 2695-10  
Part No. 126761

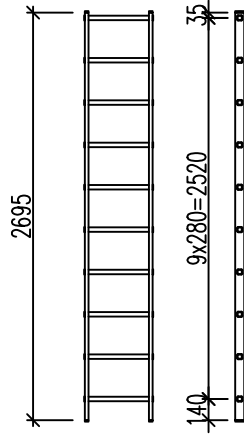

LSS Ladder 2415-9  
Part No. 126762

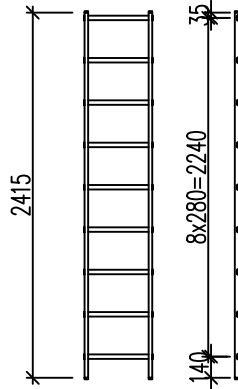

LSS Ladder 1855-7  
Part No. 126763

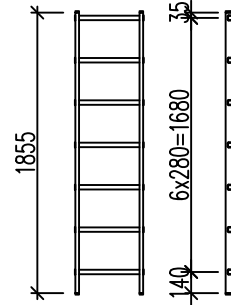

LSS Ladder 1015-4  
Part No. 126764

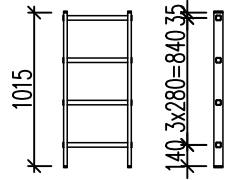

## TOP XLS Ladder support

Part No. 550024  
Weight 8.3 kg

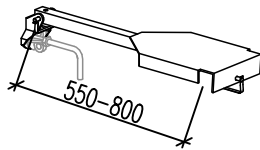

## NOEtop S ladder support

Part No. 550023  
Weight 9,4kg

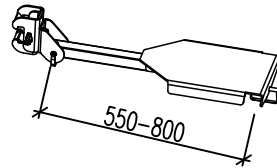

For use with hammer-head bolt  
with handle for attachment  
Part No. 319338

## Hanger head for hat profile

Part No. 556924  
(only sale)  
Weight 0,4 kg

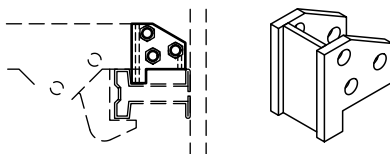

For attaching the hinged  
scaffold to the hat profile.  
The head is fixed instead of the  
standard head.

## NOEtop fixation claw

Part no. 136701  
Weight 1,2 kg

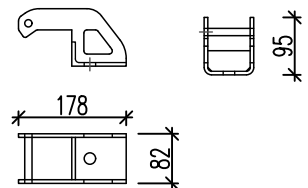

### 16.21 Raking props

#### Prop push-pull 1000-1510 mm

Part no. 697026  
Weight 9,4 kg  
perm. load 29,7 kN

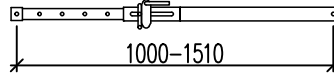

#### Prop push-pull 2100-3650 mm

Part no. 697027  
Weight 19,1 kg  
perm. load 29,7 - 12,8 kN

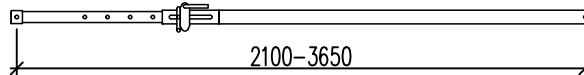

#### Prop push-pull 2800-5000 mm

Part no. 697028  
Weight 25,7 kg  
perm. load 29,7 - 6,8 kN

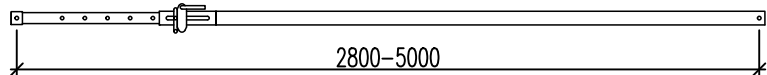

#### Prop push-pull 5000-7500 mm

Part no. 697133  
Weight 60,1 kg  
perm. load 20,0 - 11,1 kN

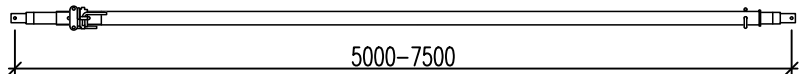

#### Base plate for push-pull brace

Part no. 697014  
Weight 3,8 kg

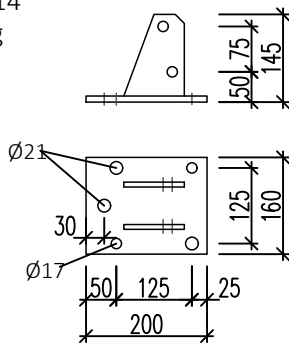

#### NOEtop stabilizer connector

Part no. 697032  
Weight 3,0 kg

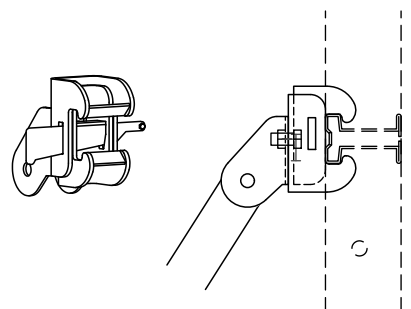

#### L-pin D16

Part no. 697010  
Weight 0,34 kg

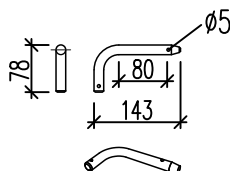

#### Spring pin 4 mm

Part no. 913304 for securing the L-pin  
Weight 0,02 kg

16.22 Formwork support

NOEtop formwork support

Adjusting range 75 mm

Part No. 164700

Weight 9,8 kg

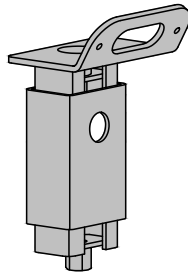

AaOM of the formwork support must be observed!

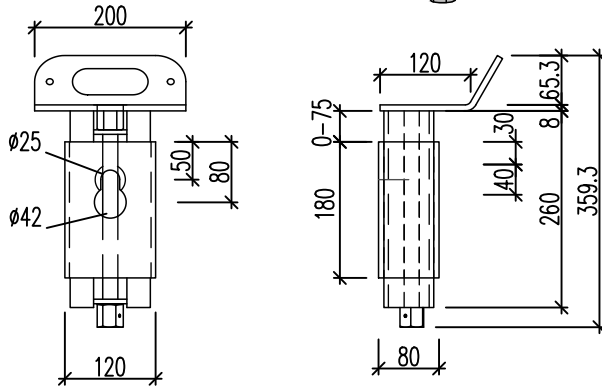

NOEtop bolt

DW 15 x 105

Part No. 164704

Weight 0,3 kg

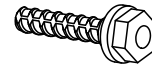

NOE anchor cap

Pack: 50 pieces

Part No. 694901

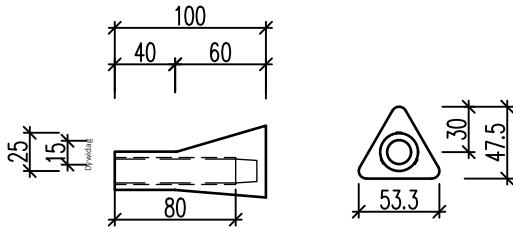

Washer form A 17 DIN 125

Pack: 250 pieces

Part No. 380027

*d = 3 mm, install 2 pieces, if the anchor cap with nailing plate was installed*

NOE plug

Pack: 50 pieces

Part No. 694904

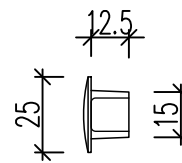

NOE nailing plate

Pack: 50 pieces

Part No. 694903

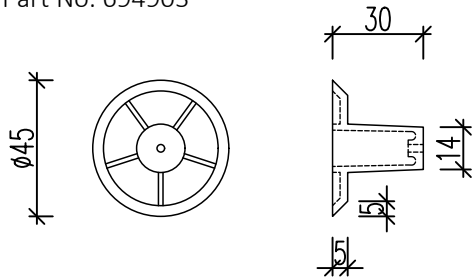

NOE nailing plug

Pack: 50 pieces

Part No. 694902

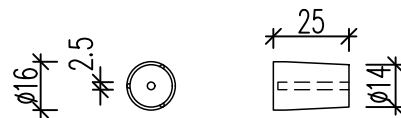

# NOEtop formwork



## Appendix I: External corner panels $b=750$ mm

NOEtop ECP 750x3310 mm  
Part No. 160077  
Weight 169 kg

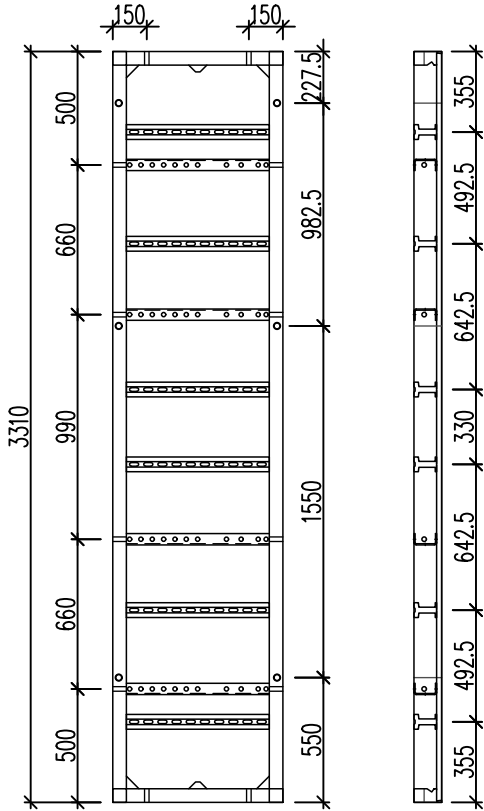

NOEtop ECP 750x2650 mm  
Part No. 167010  
Weight 137 kg

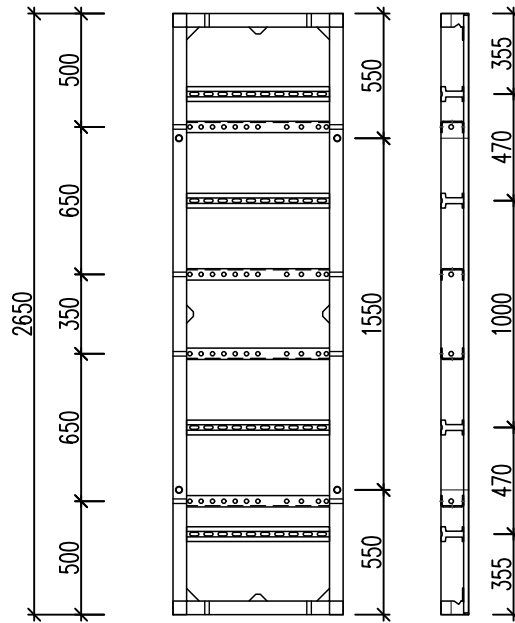

Dimensions of holes through channel

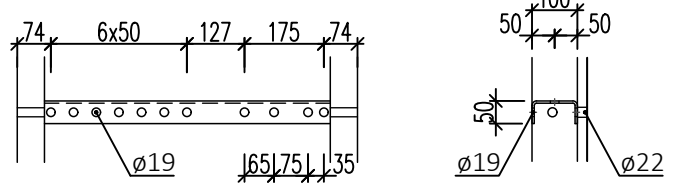

NOEtop ECP 750x1325 mm  
Part No. 167020  
Weight 71 kg

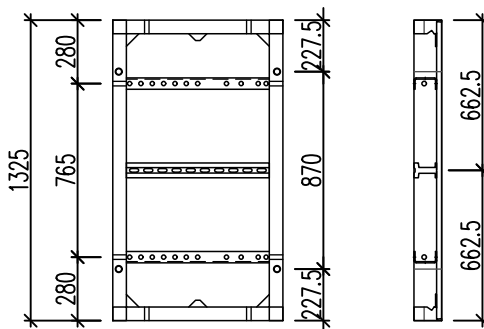

NOEtop ECP 750x660 mm  
Part No. 163010  
Weight 50 kg

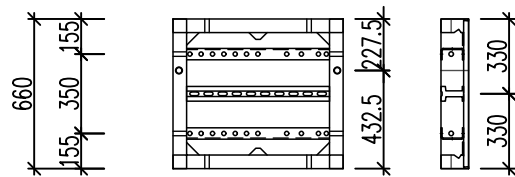

## Use of external corner panels

Elevation of showing holes through channel of a standard ECP turned

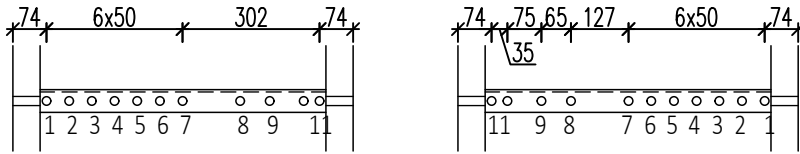

Number of connections		
Panel height	Number	
3310 mm	4	
3000 mm	4	
2650 mm	4	
1325 mm	2	
660 mm	2	

Detail A: Panel connection

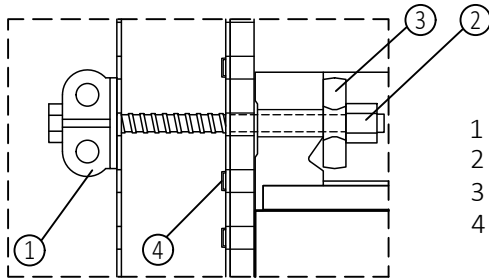

- 1 Sprint nut Part No. 680580
- 2 Connection screw Part No. 135019
- 3 Waling plate Part No. 691500
- 4 Plastic plugs Part No. 693500 for ECP

## Panels in an external corner

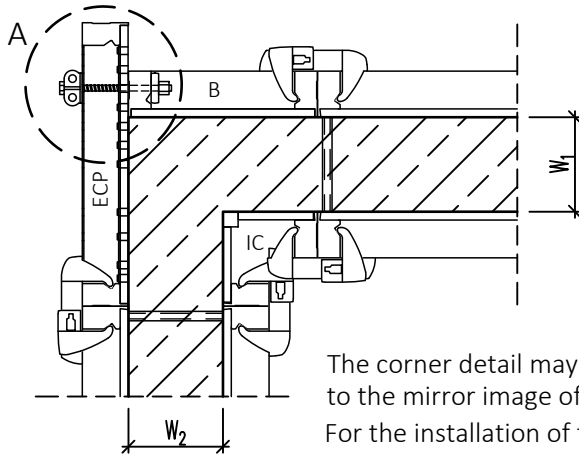

Wall thickness	W <sub>1</sub>		W <sub>2</sub>	
	Hole	ECP	Make-up panel B [mm]	Comp. piece [mm]
150	5	Normal	400	---
175	8	Turned	400	25 Outside
200	4	Normal	450	---
240	9	Turned	500	10 Inside
250	3	Normal	500	---
300	2	Normal	550	---
315	10	Turned	550	15 Outside
350	1	Normal	550	50 Outside
350	11	Turned	550	50 Outside

The corner detail may also be applied to the mirror image of the one shown.  
For the installation of the compensation piece see Chapters 5 and 6.

For arrangements to transfer tension forces refer to the information in Chapter 9!

## Panels in a rectangular column

For cross-sections from 100x100 to 600x600 mm in increments of 50 mm

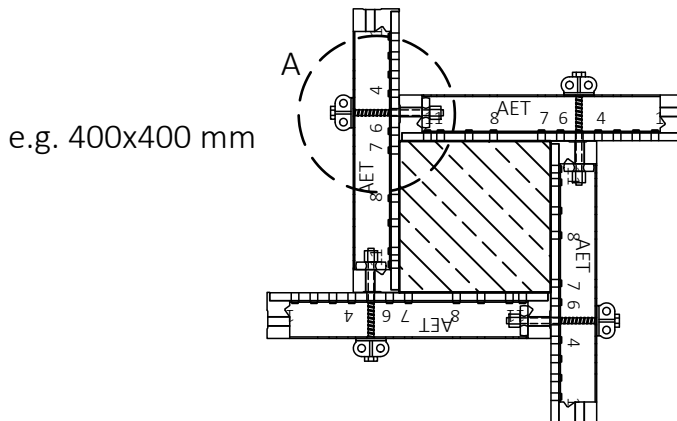

Possible column widths

Hole	ECP normal	ECP turned
1	600	---
2	550	---
3	500	100
4	450	150
5	400	200
6	350	250
7	300	300
9	---	490
11	---	600



# NOEtop formwork



## Appendix II:

Panel height 3000 mm (symmetrical panel arrangement)

Elements 3000 mm high

Width 250-1325 mm

Elevation

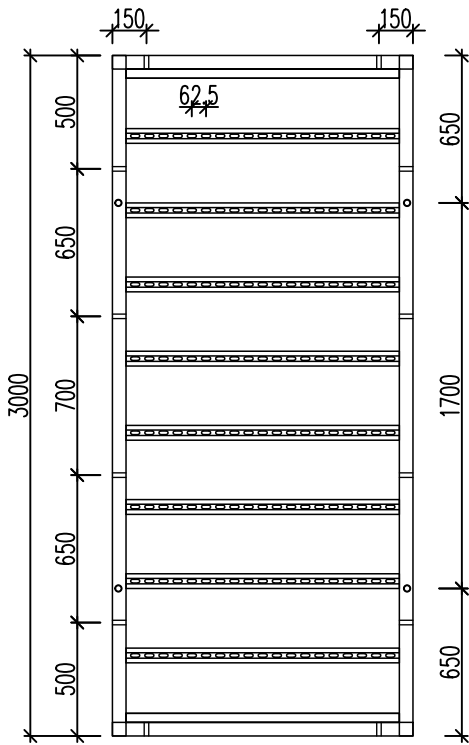

Section

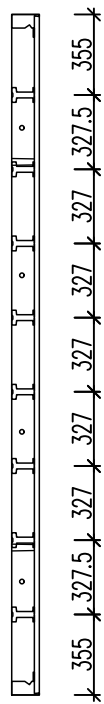

Detail of tie rod hole

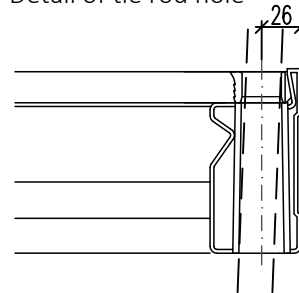

Skewed tie rod  
 For  $\phi 20$  max.  $2.2^\circ$  (equiv. 38 mm/m) For  $\phi 15$   
 max.  $5.1^\circ$  (equiv. 89 mm/m)

Profiles

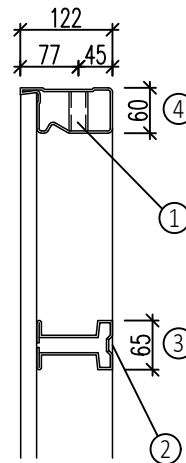

- 1  $\phi 19$
- 2 LL18/40
- 3 Hat profile
- 4 Edge profile

Panel elements  
 Height 3000 mm

Width mm	Height mm	Panel area m <sup>2</sup>	Panel with facing	
			Weight kg	Part No.
1325	3000	3,98	233,9	169942
1250		3,75	223,5	169941
1000		3,00	189,2	169944
750		2,25	155,0	169945
500		1,50	120,6	169946
450		1,35	112,4	169947
400		1,20	107,9	169948
250		0,75	85,7	169949

# NOEtop formwork



## NOEtop multifunction panel MFP

MFP 1325x3000 mm

Part No. 169935 Weight 296 kg

Section

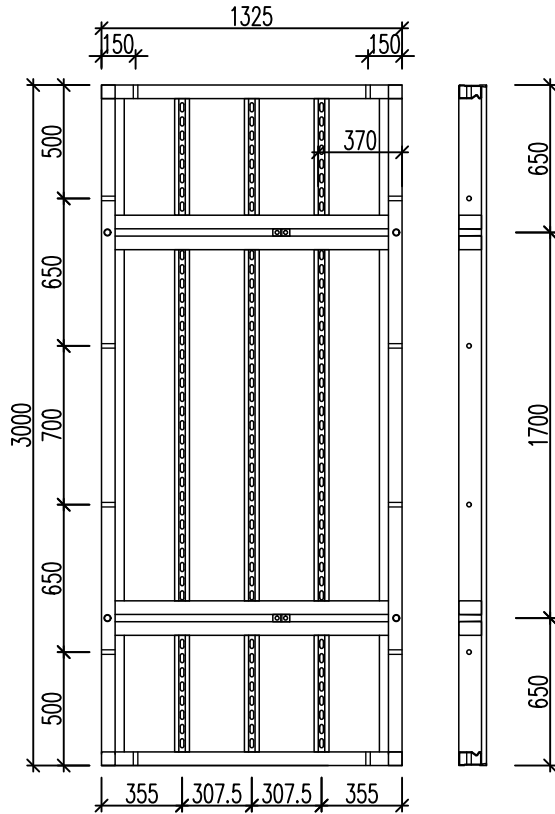

## NOEtop EC panel ECP

ECP 750x3000 mm

Part No. 169959 Weight 158 kg

Section

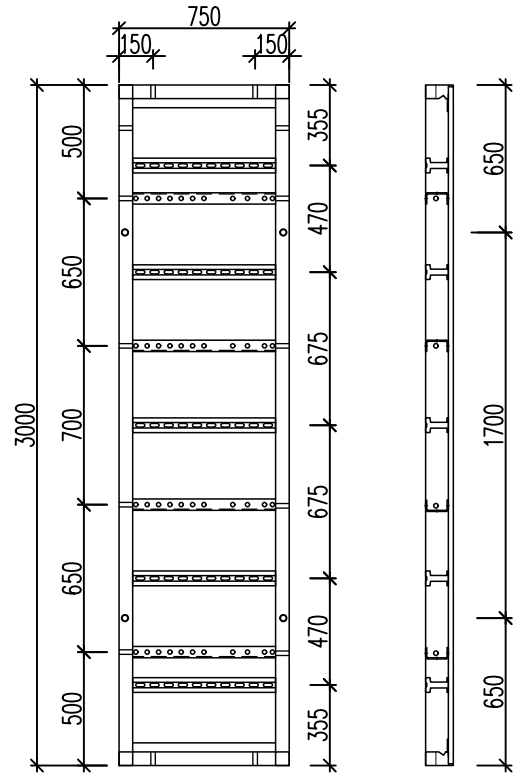

## NOEtop internal corner IC 250x250 mm

Part No. 169964

Weight 130 kg

Section

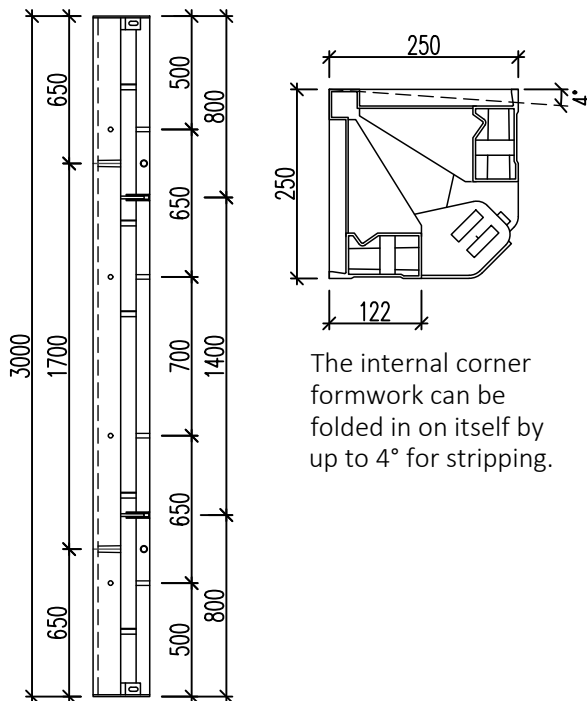

## NOEtop external corner angle ALU ECA

Part No. 164066

Weight 25 kg

Section

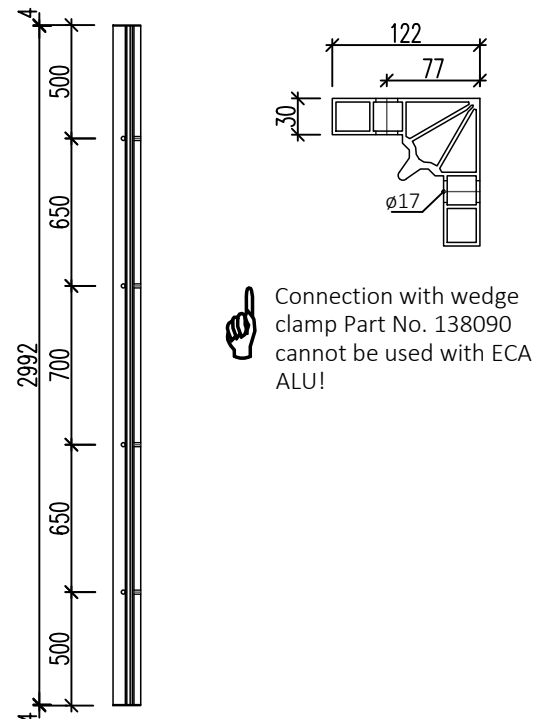

# NOEtop formwork



## NOEtop Adjustable internal corner

Part No. 164017  
Weight 111.3 kg

Section

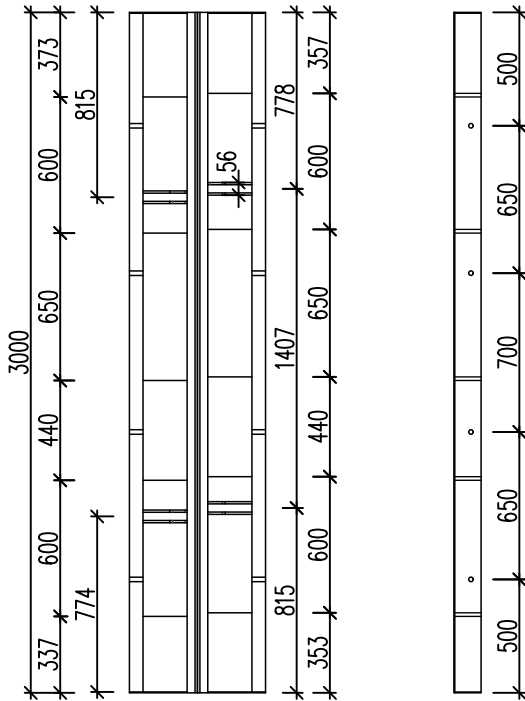

Cross-section see 16.8.

## NOEtop Adjustable external corner

Part No. 164018  
Weight 90.5 kg

Section

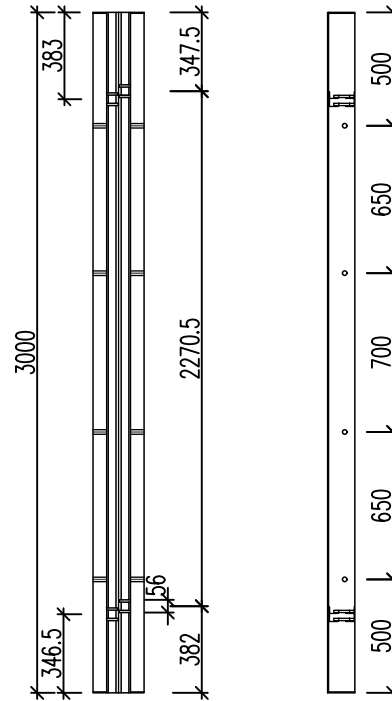

Cross-section see 16.8.

# NOEtop formwork

## NOEtop large area panel 2650x3000 mm - horizontal bracing

Part No. 169930  
Weight 533 kg

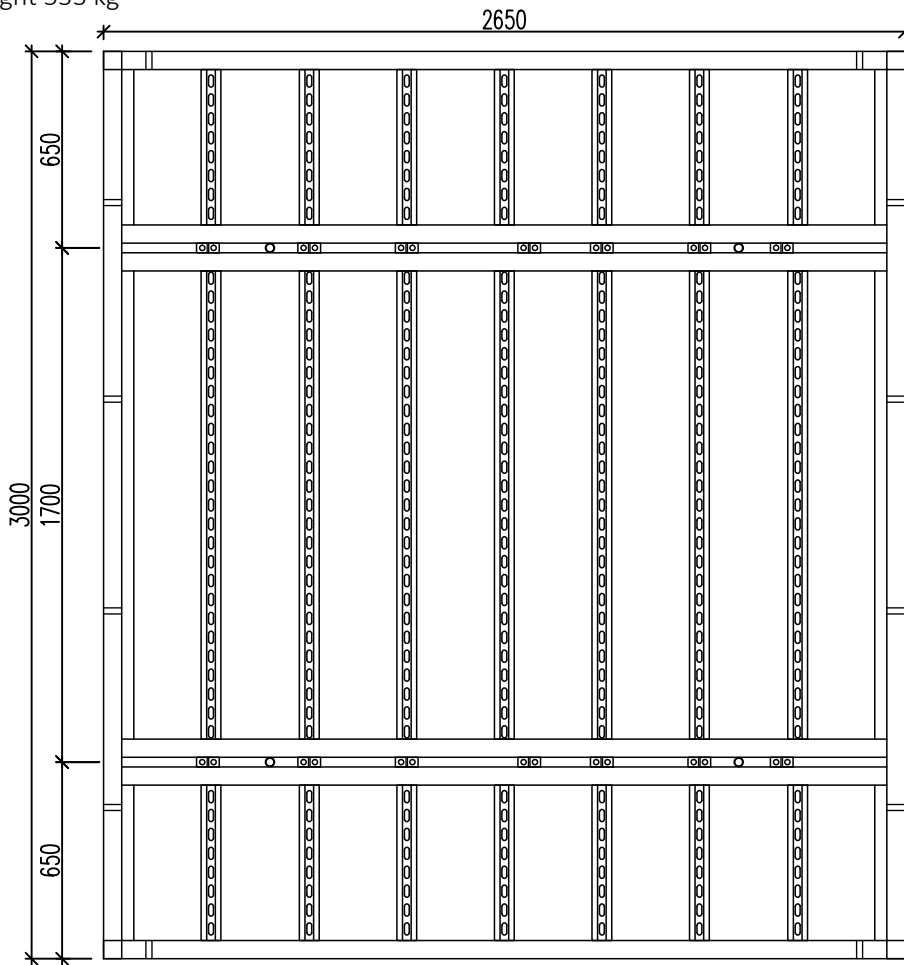

Section

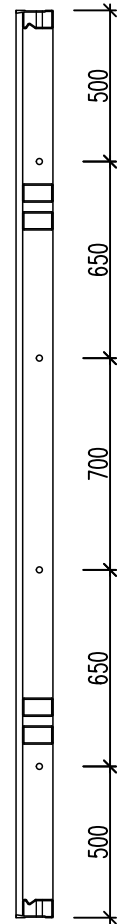

Cross-section

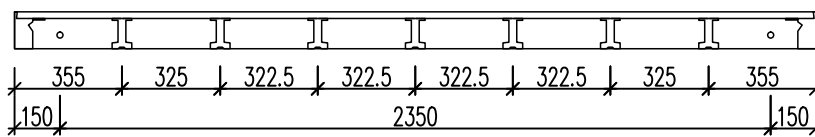

Elevation of tie rod hole pattern

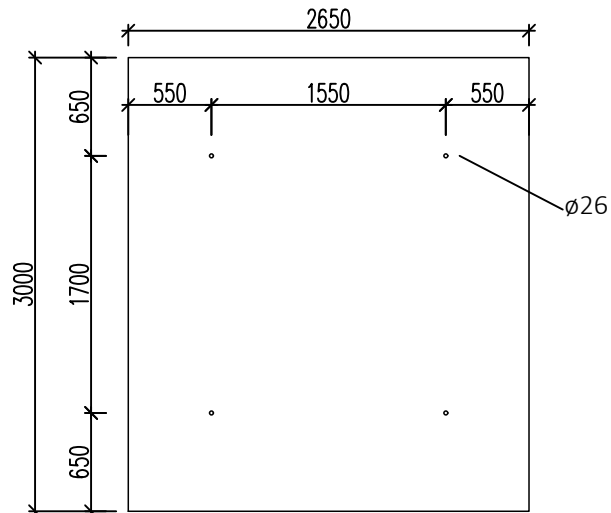

# NOEtop formwork

## NOEtop large area panel 2400x3000 mm - horizontal bracing

Part No. 169936  
Weight 504 kg

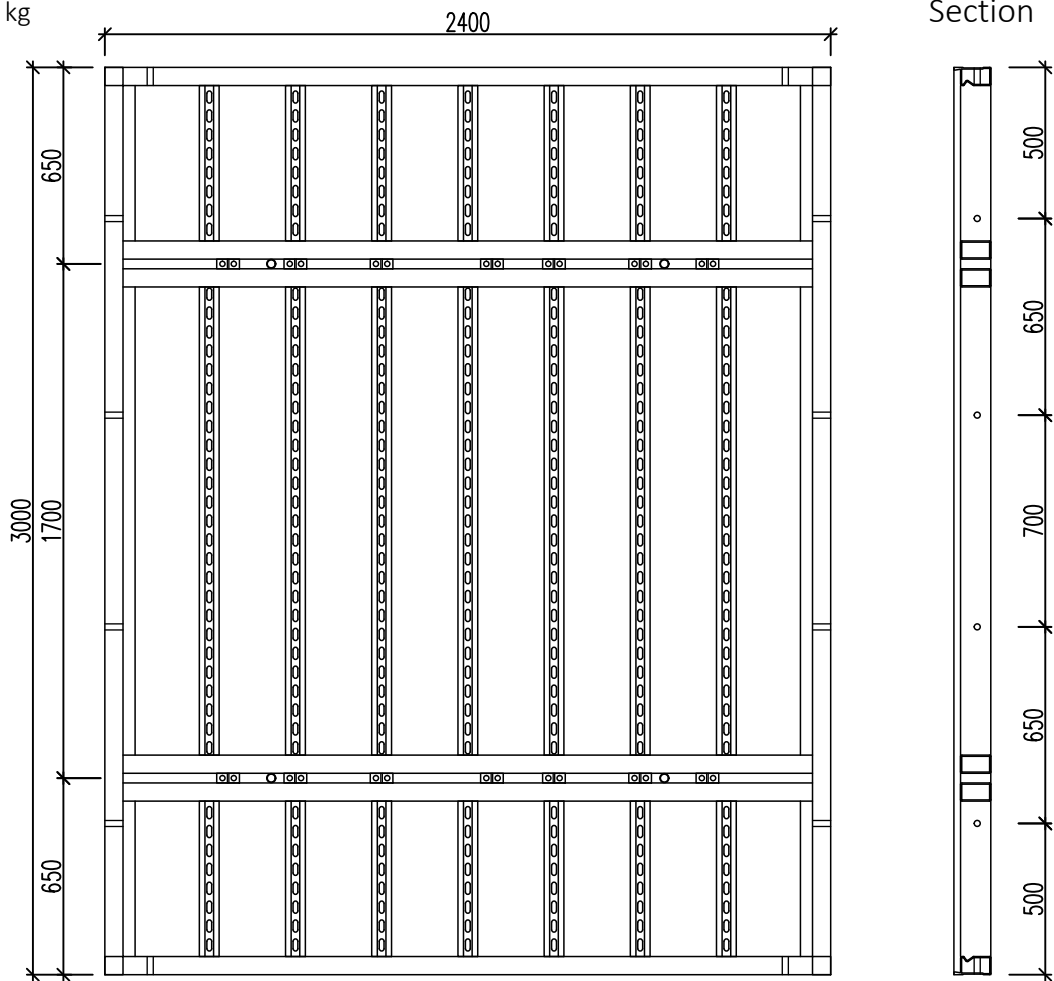

Cross-section

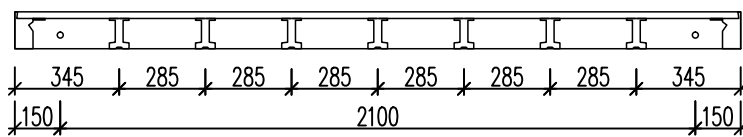

Elevation of tie rod hole pattern

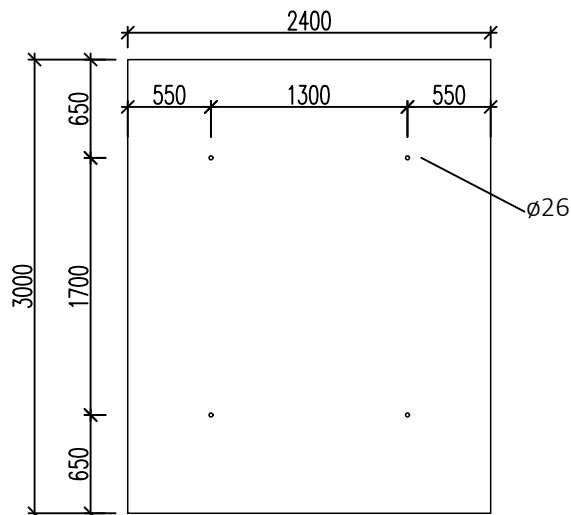

# NOEtop formwork

## NOEtop large area panel 2400x3000 mm - vertical bracing

Part No. 169931  
Weight 514 kg

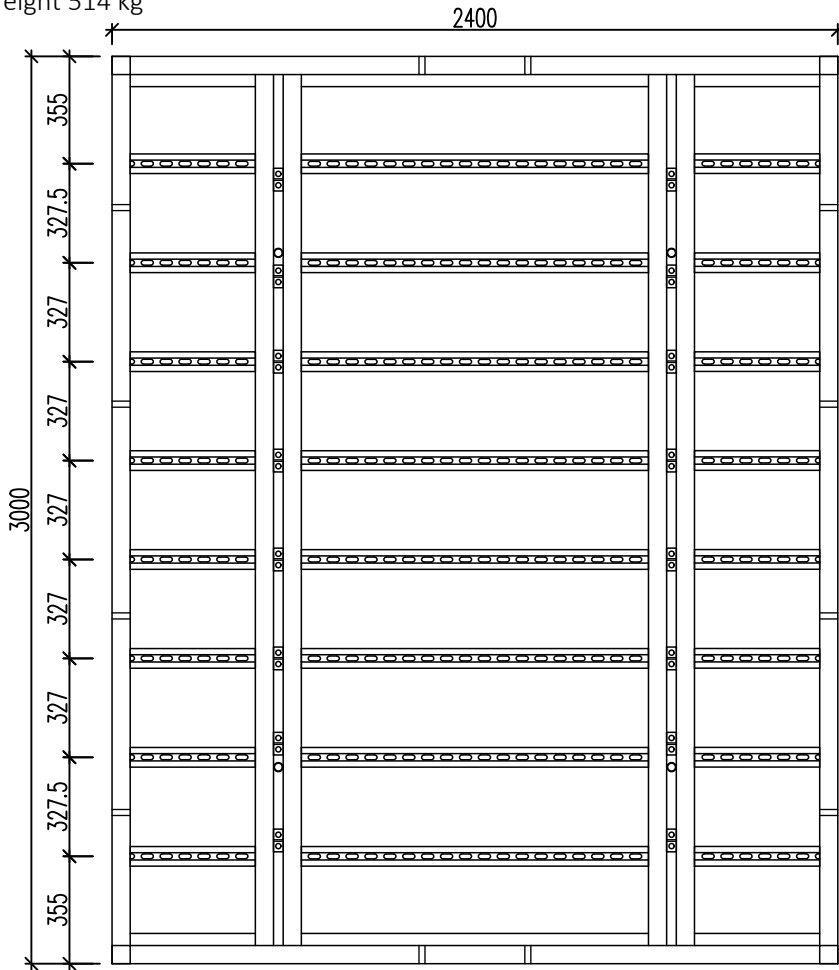

Section

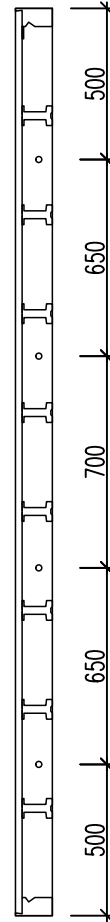

Cross-section

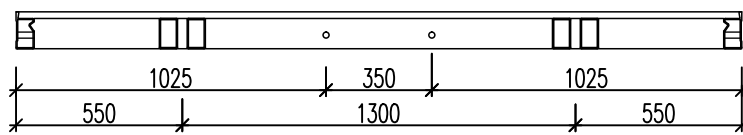

Elevation of tie rod hole pattern

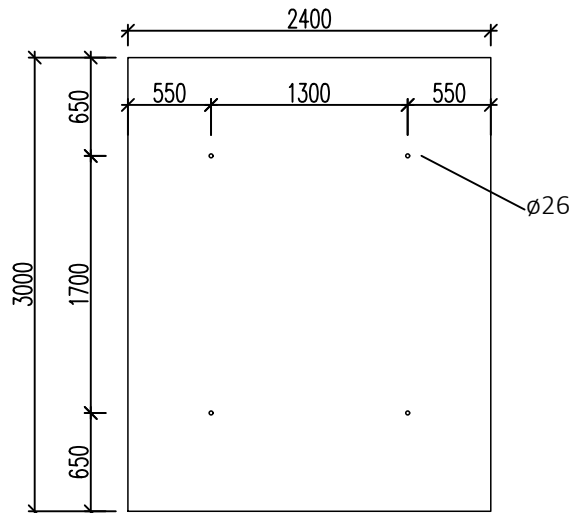

**NOE-Schaltechnik****Georg Meyer-Keller GmbH + Co. KG**

Kuntzestr. 72  
73079 Süssen  
Tel. +49 7162 13-1  
info@noe.de  
www.noe.eu

**Belgium**

NOE-Bekistingtechniek N.V.  
Leuvensesteenweg 613  
1930 Zaventem  
info@noe.be  
www.noe.eu

**France**

NOE-France  
Depot Central  
7 rue Maurice Bellonte  
02100 Saint Quentin  
info@noefrance.fr  
www.noe.eu

**Netherlands**

NOE-Bekistingtechniek b.v  
Postbus 25  
4240 CA ARKEL  
info@noe.nl  
www.noe.eu

**Austria**

NOE-Schaltechnik GmbH & Co KG  
Trientlgasse 25  
6020 Innsbruck  
noe@noe-schaltechnik.at  
www.noe.eu

**Poland**

NOE-PL Sp. z.o.o.  
ul. Jeziorki 84  
02-863 Warszawa  
noe@noe.pl  
www.noe.pl

**Switzerland**

NOE-Schaltechnik GmbH  
Nordringstrasse 28  
4702 Oensingen  
info@noe.ch  
www.noe.eu