

NOEtop4

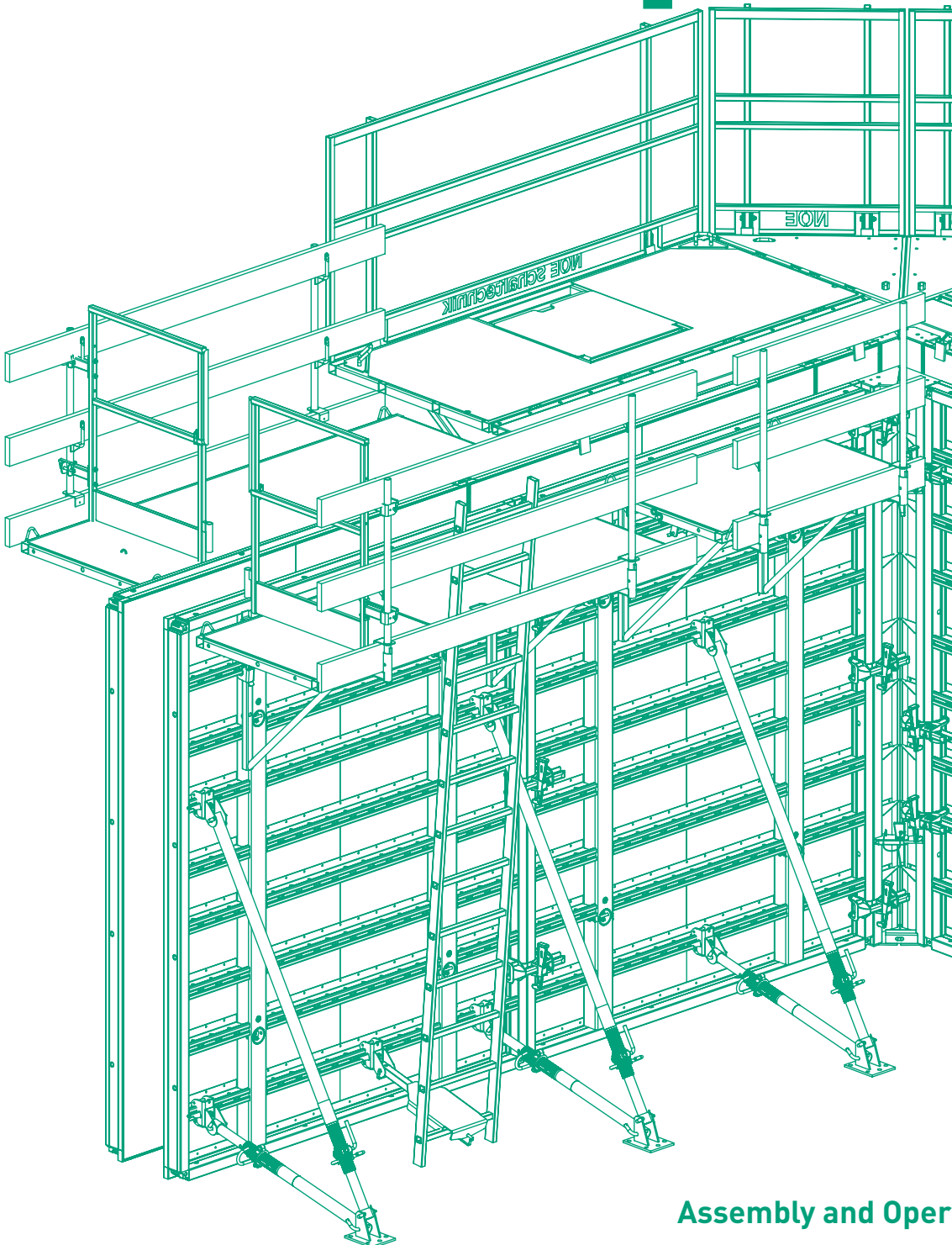





Contents

	Page		Page
1	4	12	48
1.1	4	12.1	48
1.2	5	12.1.1	48
2	6	12.1.2	48
3	8	12.1.3	49
3.1	8	12.1.4	49
3.2	8	12.1.5	50
3.2.1	8	12.1.6	50
3.2.2	11	12.1.7	51
3.2.3	14	12.1.8	51
3.3	15	12.1.9	51
3.4	15	12.2	52
3.4.1	15	12.2.1	52
3.4.2	17	12.2	53
3.5	17	12.2.1	53
4	18	12.3	55
4.1	18	12.4	55
4.2	19	12.5	59
5	20	13	60
5.1	20	13.1	60
5.2	20	13.1.1	60
5.3	20	13.1.2	62
5.4	20	13.2	63
5.5	21	13.3	63
5.6	21	13.4	63
5.6.1	22	13.5	64
5.7	24	13.6	65
6	25	13.7	66
6.1	25	13.8	68
6.2	26	13.9	70
6.3	26	13.10	70
6.4	28	13.11	71
6.5	28	13.12	71
7	29	13.13	72
7.1	29		
7.2	31		
7.3	32		
7.3.1	32		
7.3.2	33		
7.4	34		
8	35		
9	36		
10	36		
10.1	36		
10.2	37		
10.3	38		
10.3.1	39		
10.3.2	40		
10.3.3	40		
10.3.4	42		
10.3.5	43		
10.3.6	44		
10.3.7	46		
11	47		

1. Safety advice, GSV guidelines

1.1 Advice on proper and safe use of formwork and falsework

The contractor is responsible for drawing up a comprehensive risk assessment and a set of installation instructions. The latter is not usually identical to the assembly and use instructions.

- Risk assessment: The contractor is responsible for the compilation, documentation, implementation and revision of a risk assessment for each construction site. His employees are obliged to implement the measures resulting from this in accordance with all legal requirements.
- Installation instructions: The contractor is responsible for compiling a written set of installation instructions. The assembly instructions form part of the basis for the compilation of a set of installation instructions.
- Assembly and use instructions: Formwork is technical work equipment and is intended for commercial use only. It must be used properly and exclusively through trained specialist personnel and appropriately qualified supervising personnel. The assembly and use instructions are an integral component of the formwork construction. They comprise at least safety guidelines, details on the standard configuration and proper use, as well as the system description. The functional instructions (standard configuration) contained in the assembly instructions are to be complied with exactly as stated. Enhancements, deviations or changes represent a potential risk and therefore require separate verification (with the help of a risk assessment) or a set of installation instructions that comply with the relevant laws, standards and safety regulations. The same applies in those cases where formwork and/or falsework components are provided by others on site.
- Availability of the assembly and use instructions: The contractor must ensure that the assembly and use instructions provided by the manufacturer or formwork supplier are available at the place of use, that site personnel are informed of this before assembly and use takes place, and that they are available at all times.
- Representations: The representations (drawings, diagrams etc.) shown in the assembly instructions are, in part, situations of assembly and not always complete in terms of safety considerations. Any safety installations that may not have been shown in these representations must nevertheless be available.
- Storage and transportation: Any special requirements relating to transportation procedures and storage of the formwork constructions must be complied with. An example would be the use of the appropriate lifting gear.
- Material check: Formwork and falsework material deliveries are to be checked on arrival at the construction site/place of destination as well as before each use to ensure that they are in perfect condition and function correctly. Changes to the formwork materials are not permitted.
- Spare parts and repairs: Only original components may be used as spare parts. Repairs are to be carried out by the manufacturer or at authorised repair facilities only.
- Use of other products: Combining formwork components from different manufacturers carries certain risks. They are to be individually verified and can result in the compilation of a separate set of assembly instructions required for the installation of the equipment.
- Use of other products: Individual safety symbols are to be complied with. Examples:



Safety information:

Non-compliance can lead to damage to materials or risk to the health of site personnel (also life).



Visual check:

The intended operation is to be subject to a visual check.



Note:

Supplementary information for safe, correct and professional execution of work activities.

- Miscellaneous: We reserve the right to make amendments in the course of technical development. All current country-specific laws, standards and other safety regulations are to be complied with without exception for the safe application and use of the products. They form a part of the obligations of employers and employees regarding industrial safety. This gives rise to, among other things, the responsibility of the contractor to ensure the stability of the formwork and falsework constructions as well as the structure during all stages of construction, which also includes the basic assembly, dismantling and the transport of the formwork and falsework constructions or their components. The complete construction is to be checked during and after assembly.

1.2 Safe setting down of wall formwork elements

Double-faced formwork system

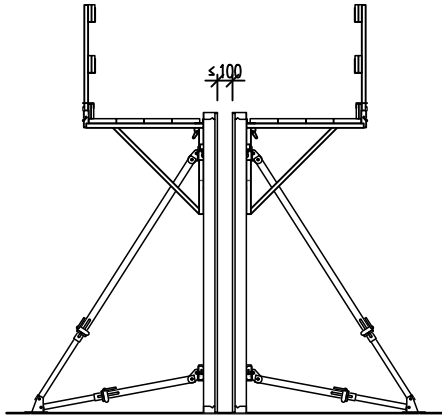

Single-faced formwork system

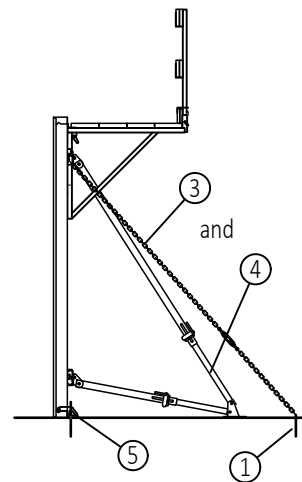
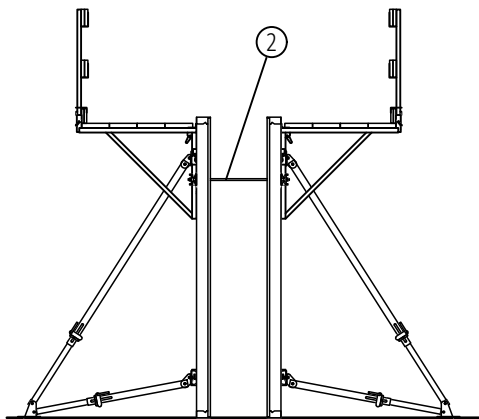
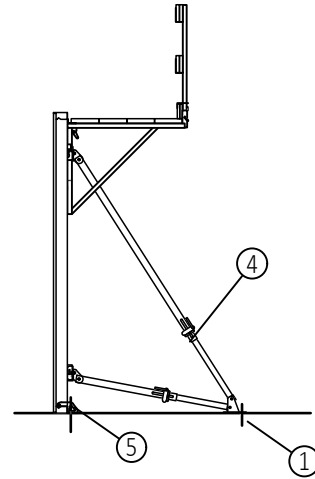



To avoid accidents always set elements down in such a way that they are structurally stable (guy, brace, anchor) this includes placing them down safely on the ground.

If the stabilizers are anchored with an anchor bolt, they must be able to act in compression and tension. At least 2 stabilizers must be attached to single panels.
Attach the uplift safety device in the event of wind loads.

For the length and fastening of the stabilizers see 15.6 and 15.7.

- 1 Anchor bolt
- 2 Tie rod
(to resist tension and compression)
- 3 Guy
- 4 Stabilizer
- 5 Uplift safety device

2. System overview NOEtop4: Frame formwork installed from one side

Tie with tapering NOEtop4 tie rod DW20
permissible concrete pressure 80 kN/m² in acc. with DIN 18218!

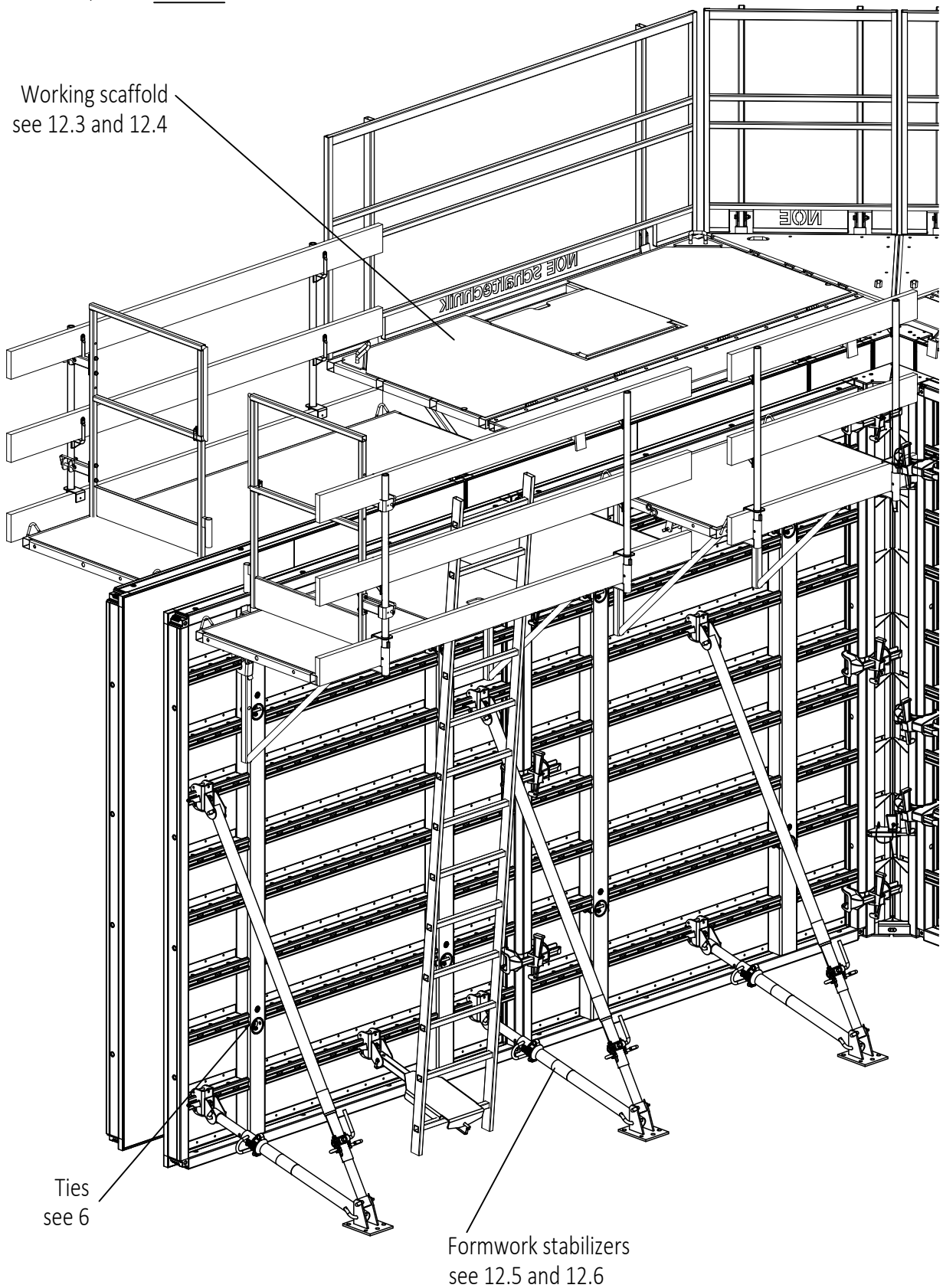

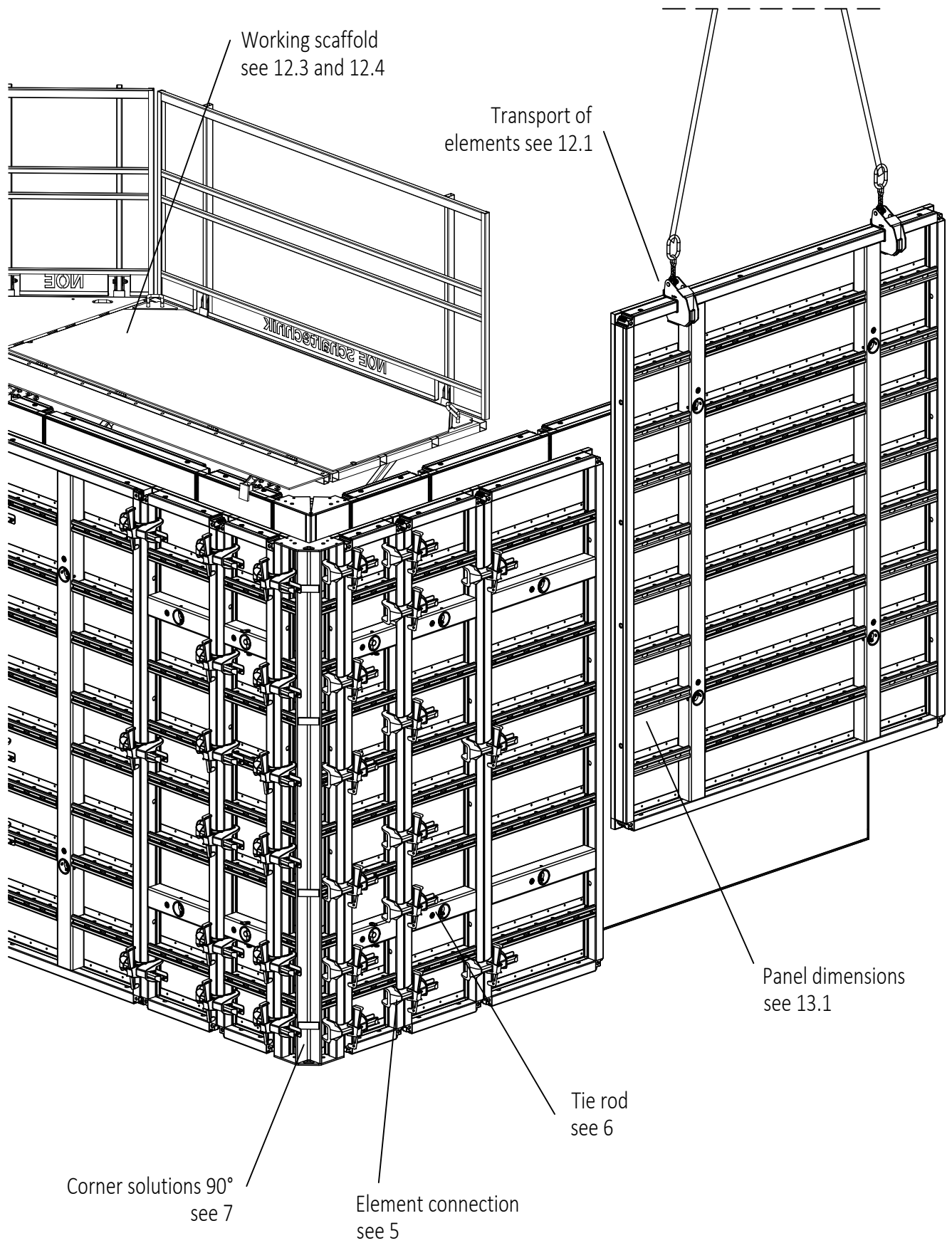

3. Assembly instructions

The individual steps for assembly and erection are shown diagrammatically in the following pages. When erecting formwork, we recommend that you start at a corner; when stripping formwork, it is best to start from the stopend form or from the compensation piece to the corner, as appropriate.

→ Indicates relevant chapters, where the steps are shown in detail.



Before using the formwork, read through the assembly and use manual and observe the safety advice given in each section at all times!

Everyone who works with the product must receive instruction from a suitably qualified member of the site supervisory staff.



A risk analysis covering all situations on site must be carried out by a responsible person.

Components must be free of defects. Therefore visual inspection and/or testing of each component are essential at all stages of the work!

3.1 Unloading formwork elements

⇒ Refer to 12.1 for transporting formwork

3.2 Erecting formwork

3.2.1 Preassembling the first face formwork

- ◆ To assemble the elements into one unit, lay the panels down on a suitable level surface and connect them using formwork locks. Support the face on e.g. lengths of squared timber to avoid causing damage to the formwork lining.

⇒ Refer to Chapter 5 for connection elements

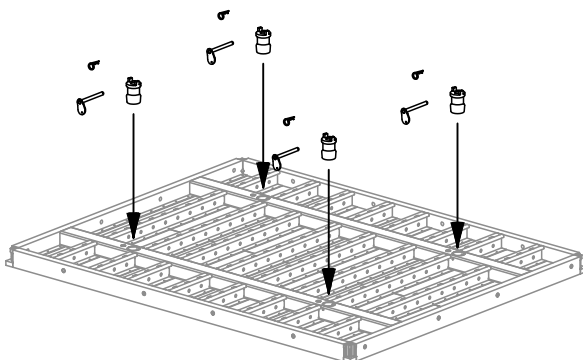
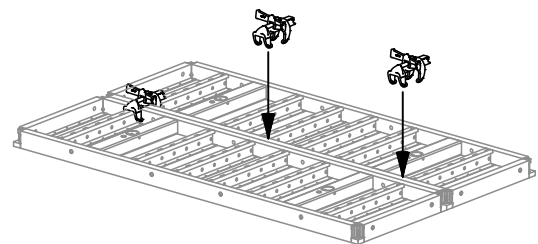

- ◆ Insert fixed bearing into the bearing shell and secure



Check that they are properly seated and securely fastened in place!

⇒ Observe 6.2 for preparation of first face formwork

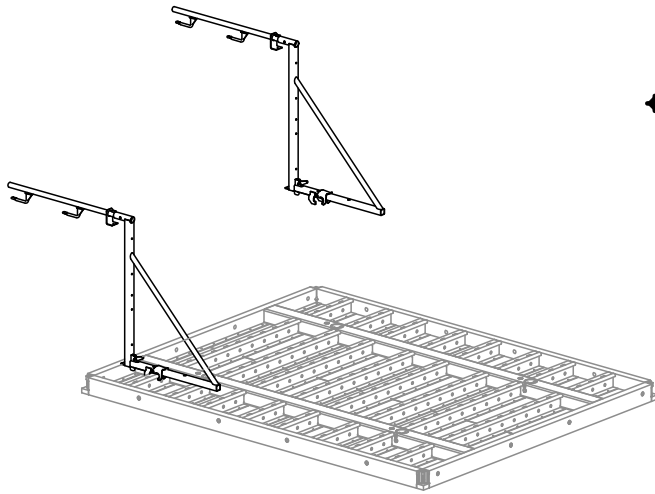

◆ Suspend walkway brackets in hat profile



Check that they are properly seated and securely fastened in place!

⇒ Refer to 12.3 and 12.4 for walkway brackets

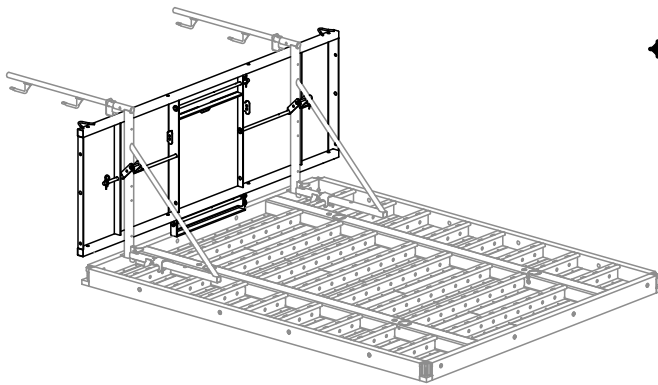

First element with platform and trapdoor

◆ Attach NOEtop working platform (1st element) and/or scaffold planks (and all additional elements).

⇒ Refer to 12.3 and 12.4 for scaffolding

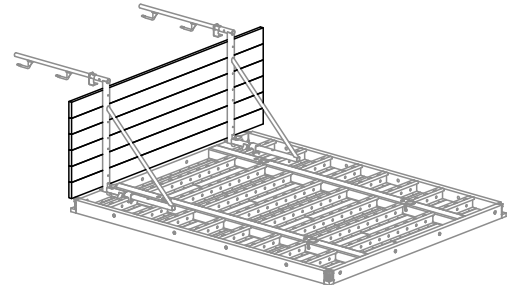

Additional elements with boarding

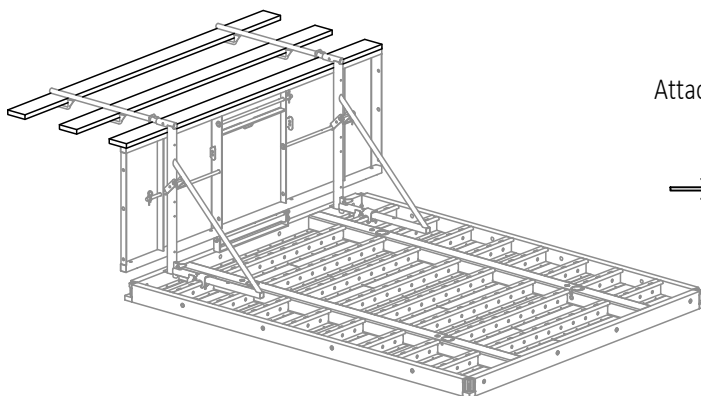

Attach guardrail boards and toeboard.

⇒ Refer to 12.3 and 12.4 for scaffolding

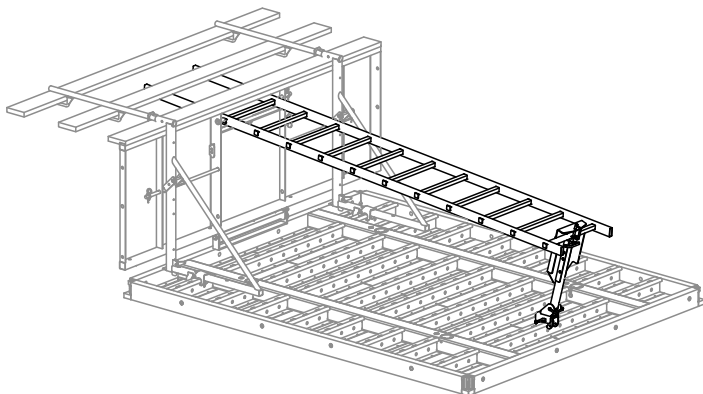

- ◆ On 1st element: Attach ladder support to the panel and fasten the ladder to the support and to the working platform.

⇒ Refer to 12.3 for scaffolding

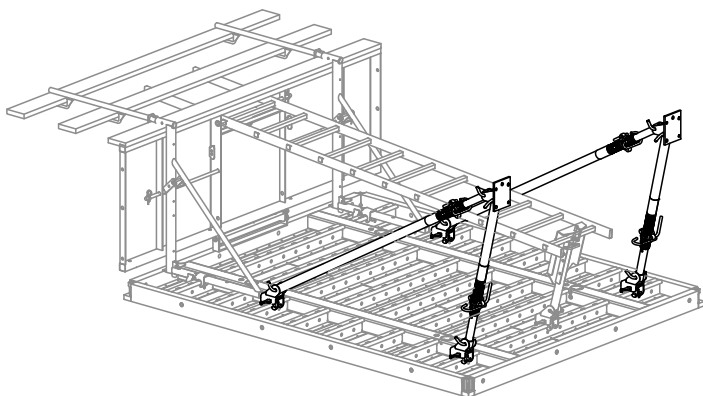

First element with 2 stabilizers

- ◆ Attach stabilizers (2 No. on the first combined element, 1 No. on each further element).

⇒ Refer to 12.5 and 12.6 for stabilizers

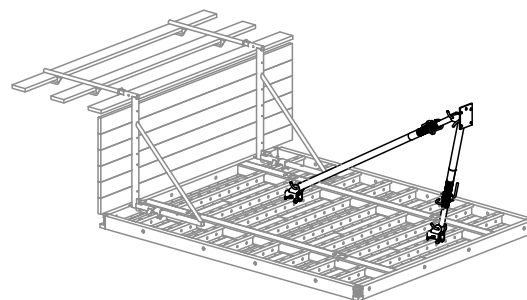

Each further element has one stabilizer

- ◆ Attach guard-rail clamps and guardrail boards to the first and last elements of a length of the object to be cast (if required also at corners, stepped projections etc.) to prevent falls from the open platform ends.

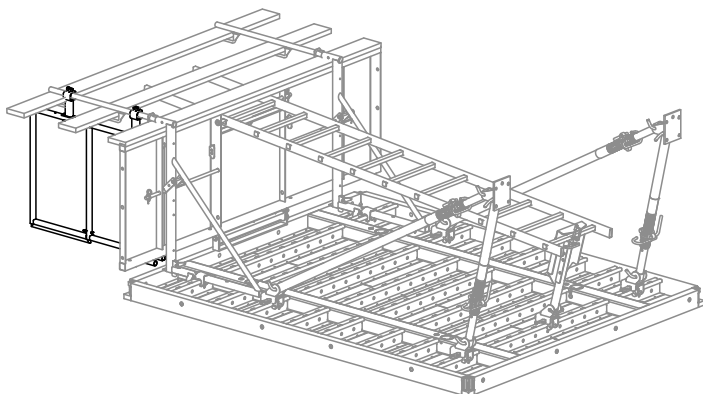

End protection with scaffold platform adapter handrail tube Part No. 550025 and handrail tubes.
Alternatively: End protection with NOEtop front guard-rail (see 15.5.2)

- ◆ Erect element as described in 3.2.2 and preassemble the other elements for the length of the object to be cast, as described above.

3.2.2 Erecting the first face formwork

	For safe transport: Do not exceed the maximum permissible load on the crane hook!		max. 20 kN vertical → Refer to table in 12.1.4 → Operating instructions
--	--	--	---

- ◆ Sling crane hook with hanger and lift the combined unit slowly with the crane (if the lift is too rapid the stabilizer may strike the ground!).

→ Refer to 12.1 for transporting formwork

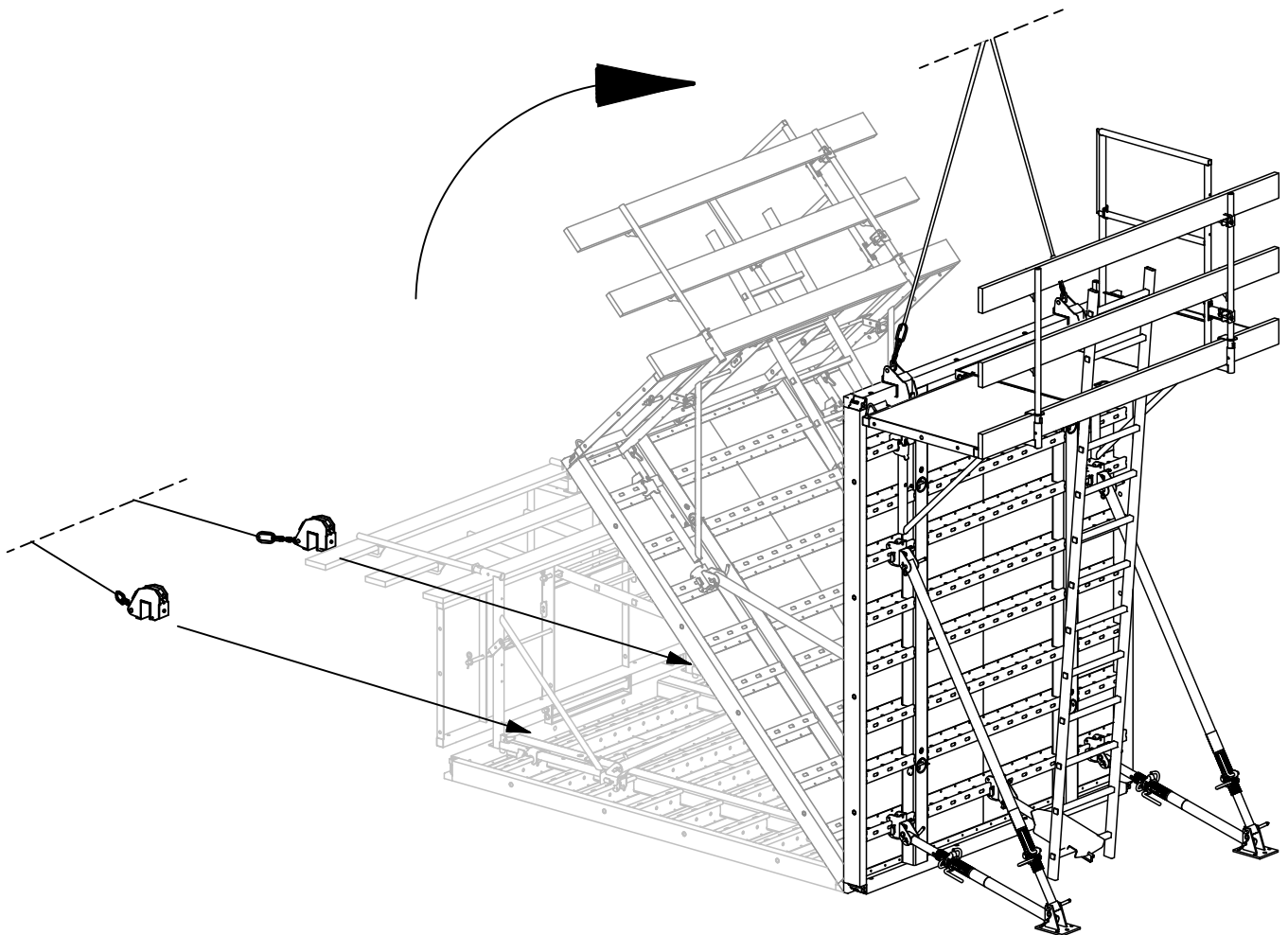

NOEtop4 Formwork



- ◆ Once the combined element has been placed and correctly aligned in its installation position, anchor the element stabilizers to the base using a force-transmitting anchor.

⇒ Refer to 12.5 and 12.6 for stabilizers

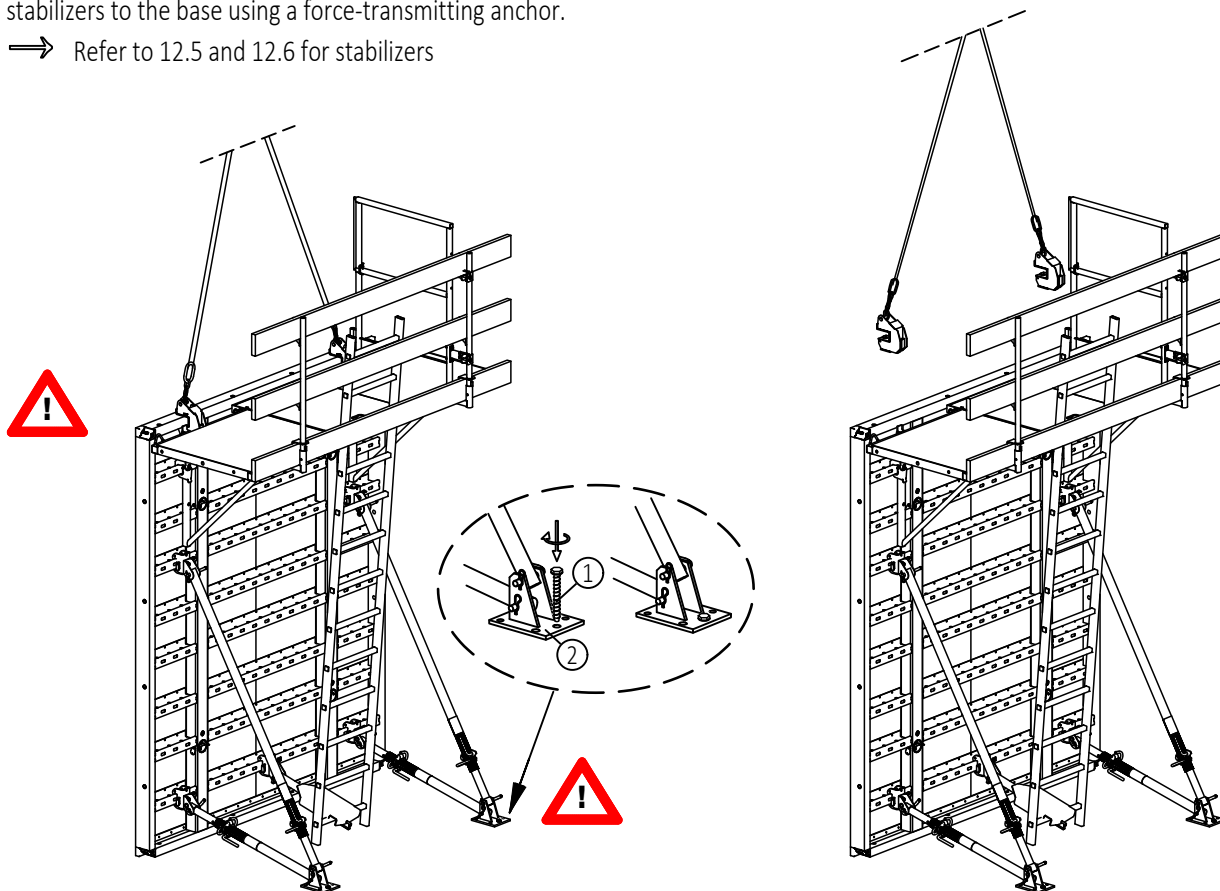

- 1 Bolt MMS plus 16x130
Part No. 313151
- 2 Bottom support

- ◆ Once the stabilizers have been fastened in accordance with the instructions, climb up the ladder on to the platform and disconnect the crane hook whilst standing on the platform.

⇒ Refer to 12.1.4 for crane hook

Anchor the stabilizers against tension and compression forces to ensure structural stability before releasing the crane hook.

ATTENTION: Danger of falling inside the formwork!
(For heights > 2 m take precautions to ensure safety against falling!)

⇒ see 12.4

NOEtop4 Formwork



- ◆ Preassemble the other elements in accordance with 3.2.1 and lift them into place in the installation position with the crane.

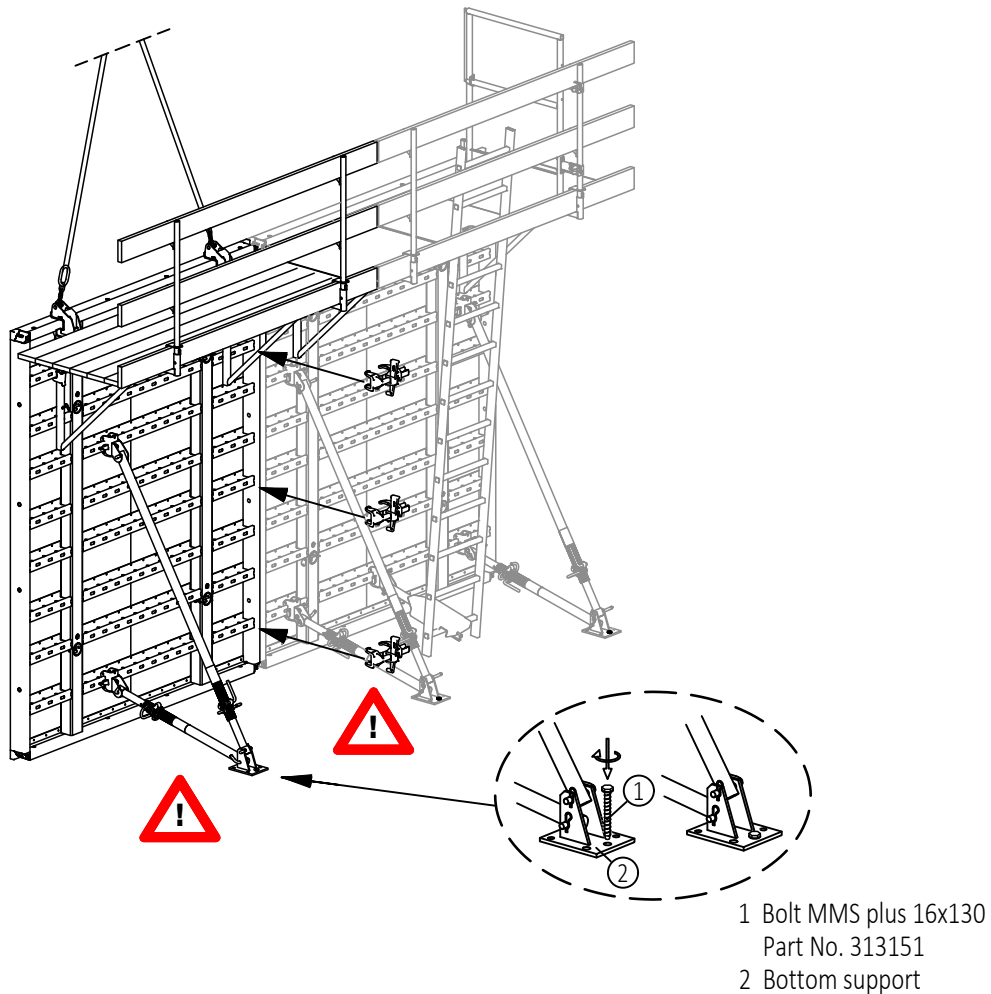

- ◆ Attach the first connections and anchor the stabilizer using a force transmitting anchor, then detach the crane hook whilst standing on the platform.
To reach this point use the ladder to climb up to the working platform of the first element, climb through the trapdoor and walk along the platform from there.



Anchor the stabilizers against tension and compression forces and attach connection to ensure structural stability before releasing the crane hook.

ATTENTION: Danger of falling inside the formwork!
(Ensure safety against falling from heights > 2 m by providing suitable measures!)
⇒ see 12.4

ATTENTION: Danger of falling from the open scaffold side, take appropriate care!

3.2.3 Installing the (opposing) second face formwork

- ◆ Preparing the first face formwork: apply release agent to the front and rear formwork faces in accordance with the formwork preparation instructions, fix reinforcement in position.



If no fall protection measures were attached to the first face formwork for formwork heights > 2.00 m then the appropriate safety measures must now be installed (if necessary preattach the fall safety measures while the second face formwork is on the ground).

⇒ Refer to 12.4 for fall protection

- ◆ Attach the crane hook to the second face formwork, lift it with the crane, apply release agent to the front and rear face in accordance with the formwork preparation instructions and place it in the installation position

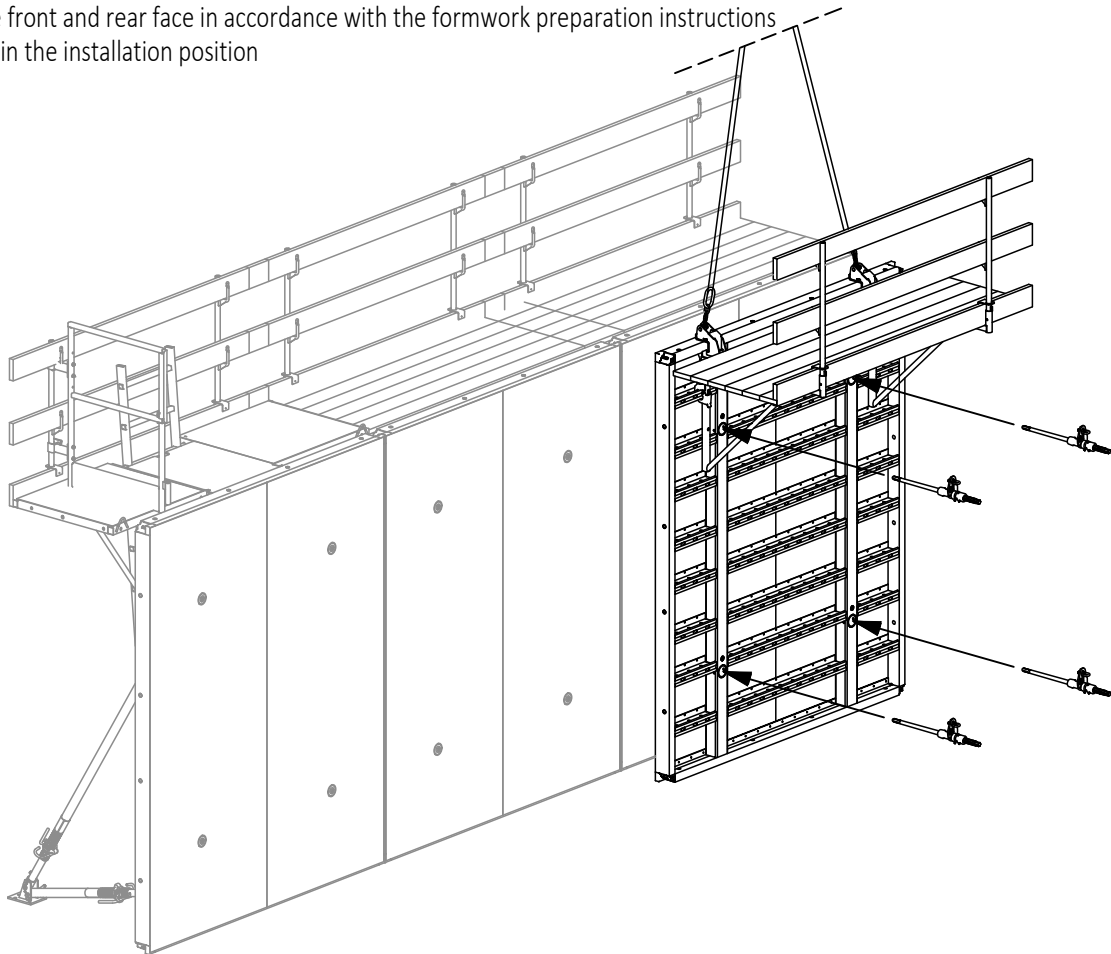

- ◆ Install tapering tie rod appropriate for the wall thickness and seal any surplus tie rod holes with sealing pins.

⇒ Refer to 6.3 Closing the formwork and 6.4 Closing the unused tie rod holes



Do not release the crane hook until after the tie rods are installed for the first element and, in the case of further elements, a top tie rod is installed and tensioned and the connections are installed.

- ◆ Once the element is secured, climb the ladder to the platform on the first face formwork and detach the crane hook from there. Pay particular attention to the danger of falling! Alternatively the crane hook can be detached from at ground level.

⇒ Refer to 12.4 for fall protection and 12.1 for crane transport

- ◆ Repeat this procedure for the full length of the object to be cast.

3.3 Concreting

 Before concreting starts check the anchors, ties and connections for

- Completeness
- Correct positioning
- Effective locking

- ◆ Do not exceed the permissible pressure during concreting (DIN 18218 "Pressure of fresh concrete on vertical formwork"), i.e. pay attention to the rate of rise of the concrete.

- for one-sided ties $\varnothing 20$ mm permissible concrete pressure 80 kN/m²
- for two-sided ties $\varnothing 20$ mm permissible concrete pressure 80 kN/m²

- ◆ If using internal vibrators refer to DIN 4235 Part 2 "Compaction of concrete by internal vibrators".

3.4 Stripping formwork

3.4.1 Stripping second-face formwork

 Before stripping first check:

- Minimum stripping times!
- Concrete compressive strength!

When stripping start with the panels without stabilizers!

- ◆ Attach the crane hook with a hanger to secure the element or combined element. Access for this operation is from the opposite platform.

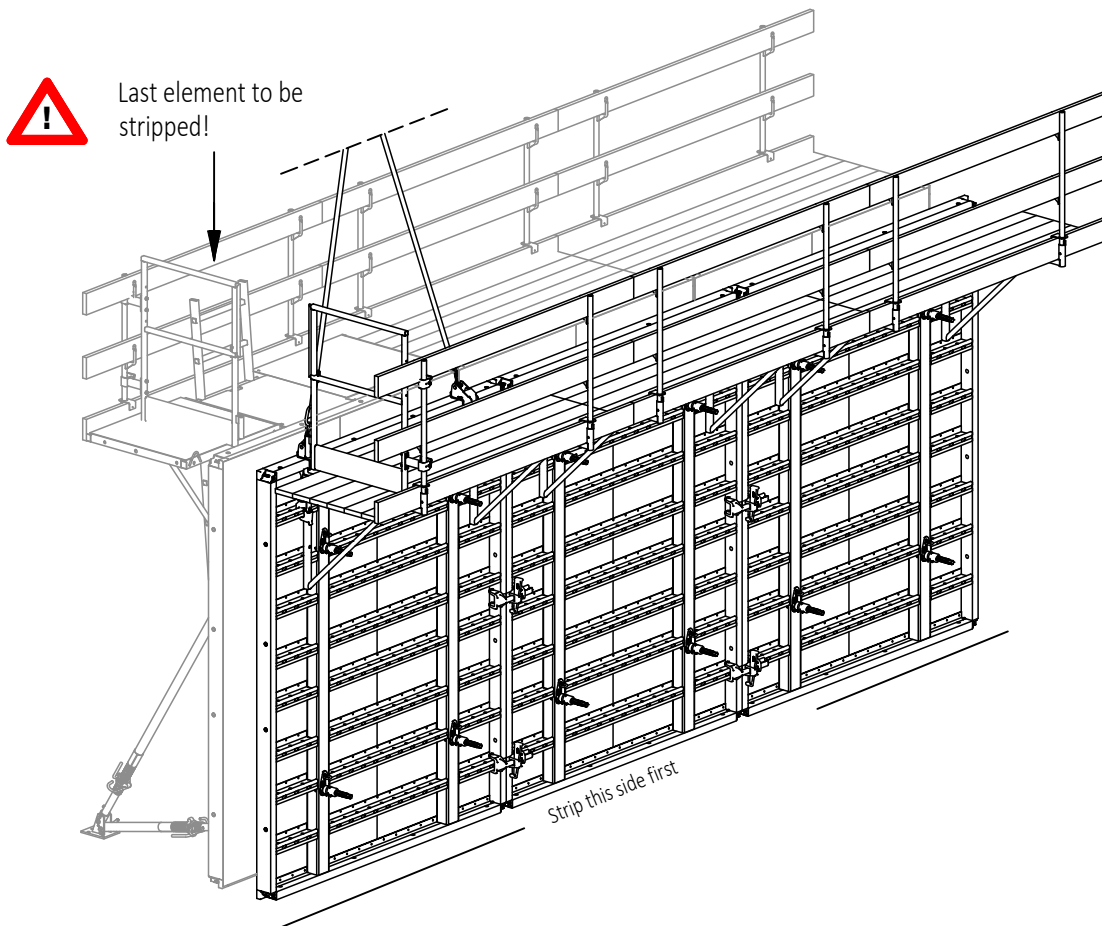

NOEtop4 Formwork

- ◆ Remove the tapering tie rods from the elements or element combinations to be stripped, remove the connectors to the adjacent element and release the element from the concrete.
Use pry bars or similar tools on the corner casting; never pull panels free with a crane.

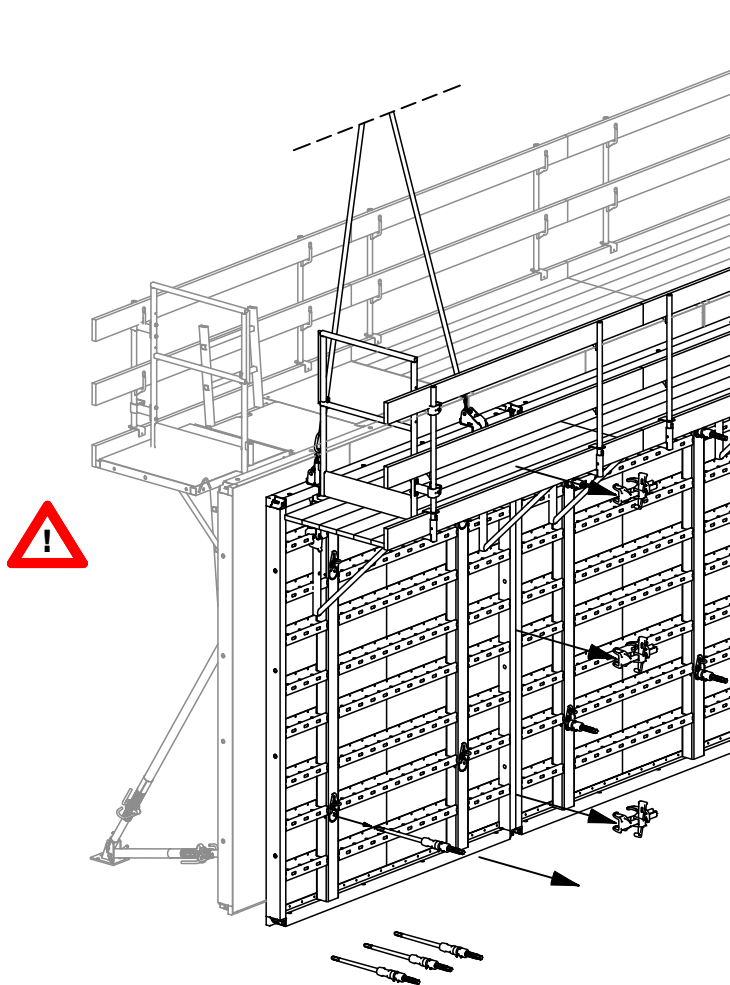

Never use a crane to pull formwork panels off the concrete!

Do not stand close to the back of the panel; it may swing out!





If a panel is proving difficult to strip, check again that all the tie rods have been removed!

- ◆ Place the element down in a stable position (see 1.2) and detach the crane hook (see 15.1.6).
- ◆ Clean the formwork elements before each further use and apply release agent.

3.4.2 Stripping the first face formwork - formwork with scaffolding

- ◆ Remove any loose parts from the platform and, whilst working from the platform, attach the crane hook and hanger to the combined element.

 To ensure safe access:
Strip the combined element with trapdoors in their platforms last



Never use a crane to pull formwork panels off the concrete!

Do not stand close to the back of the panel; it may swing out!

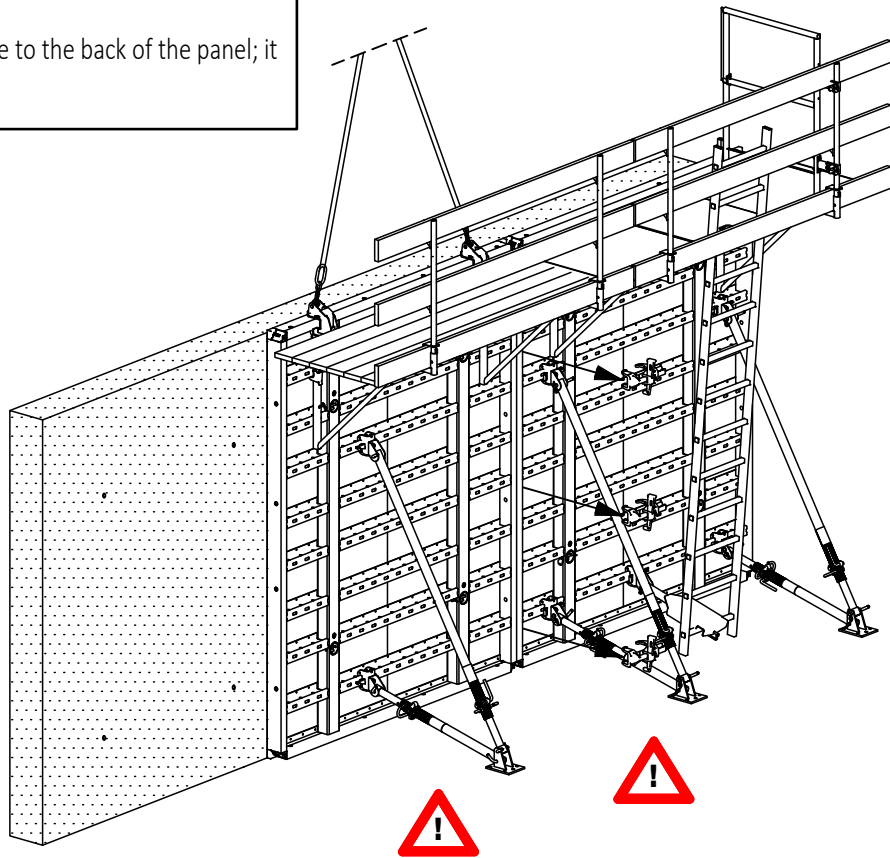

- ◆ Loosen the anchors to the stabilizers, remove the connectors to the adjacent combined unit and free the element from the concrete. Use pry bars or similar tools on the corner casting to do this; never pull panels free with a crane.
- ◆ Place the element down in a stable position (see 1.2) and detach the crane hook (see 12.1.6).

3.5 Preparation for transport

- ◆ Dismantle stabilizers, scaffolds and elements. Refer to Section 3.2 using reverse order.
- ◆ Stack the cleaned elements and bind them into suitable groups for safe transport. Place small parts in NOE boxes for transport.
⇒ Refer to 12.1 for transporting formwork

4. Standard construction

4.1 Formwork height 3000 mm

◆ Elevation

- Ties with tapering NOEtop4 tie rod DW20 permissible concrete pressure 80 kN/m² in acc. with DIN 18218!
- Ties with DW20 tie rod + sleeve permissible concrete pressure 80 kN/m² in acc. with DIN18218!

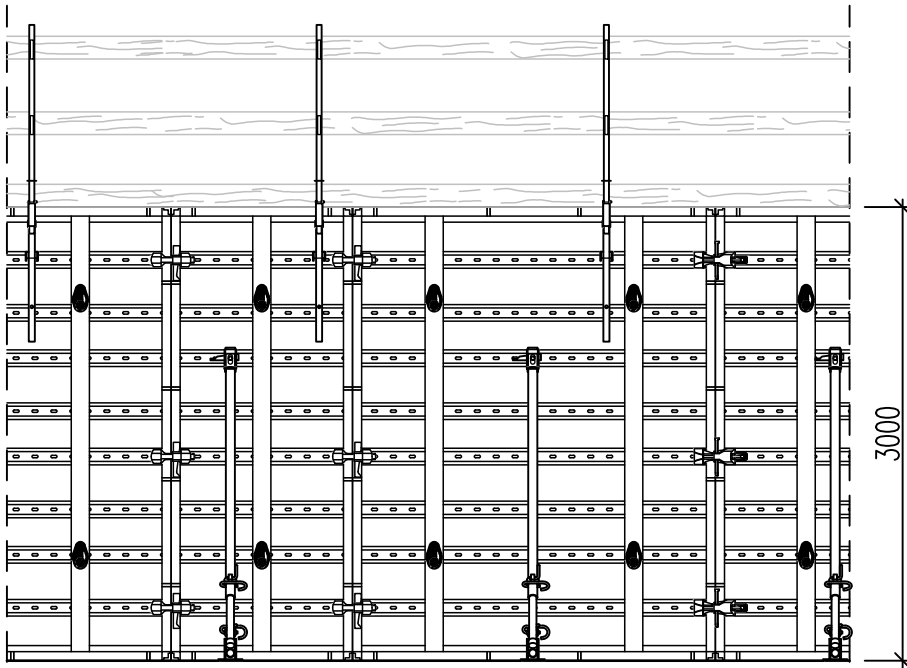

Butt joint with Toplock V
Part No. 137976

Butt joint with Toplock X
Part No. 137960

◆ Section

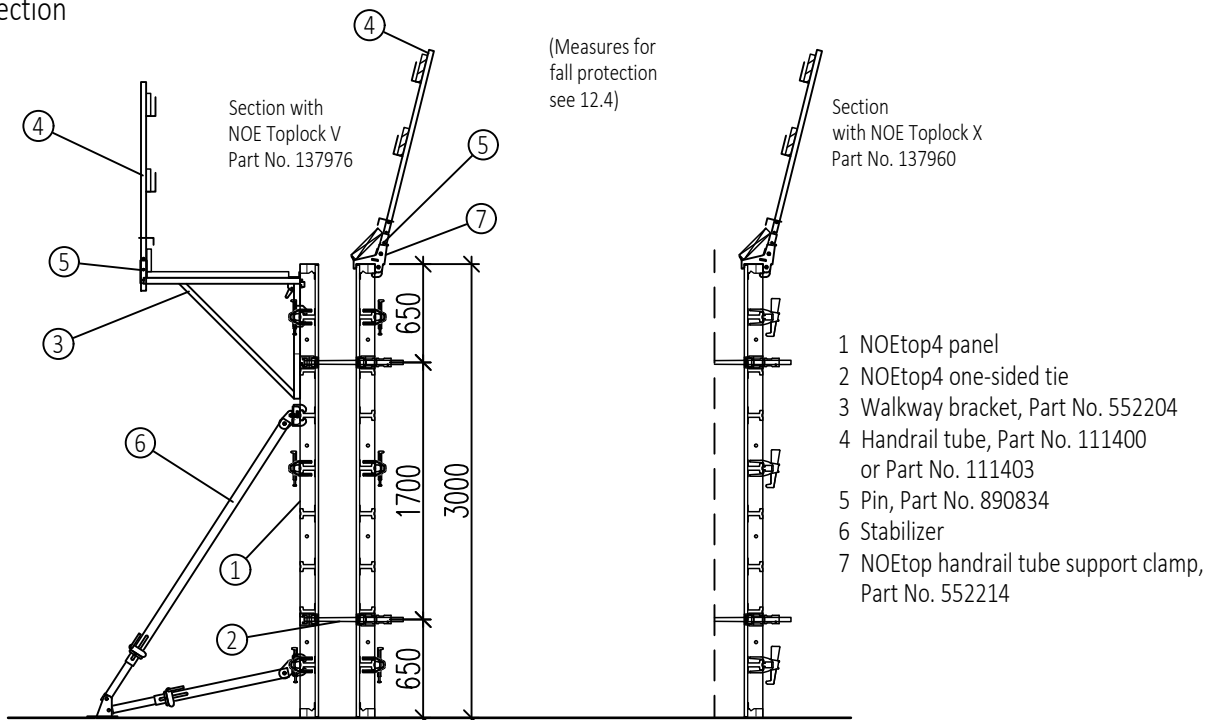

4.2 Formwork height 3600 mm

Permissible concrete pressure - see Item 4.1

◆ Elevation

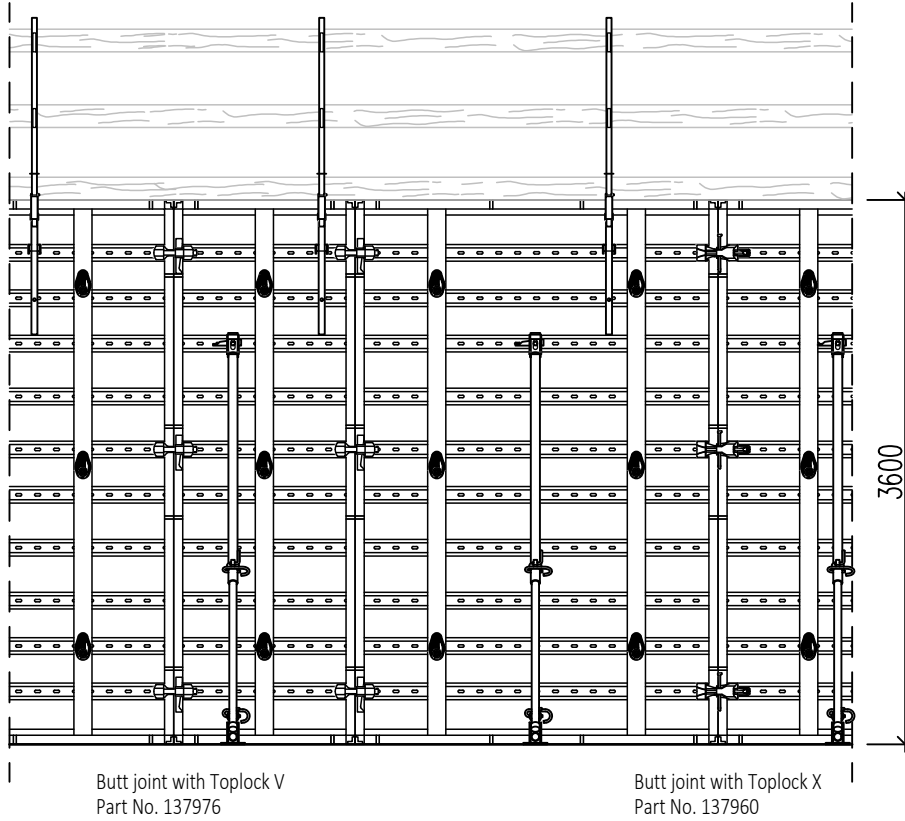

◆ Section

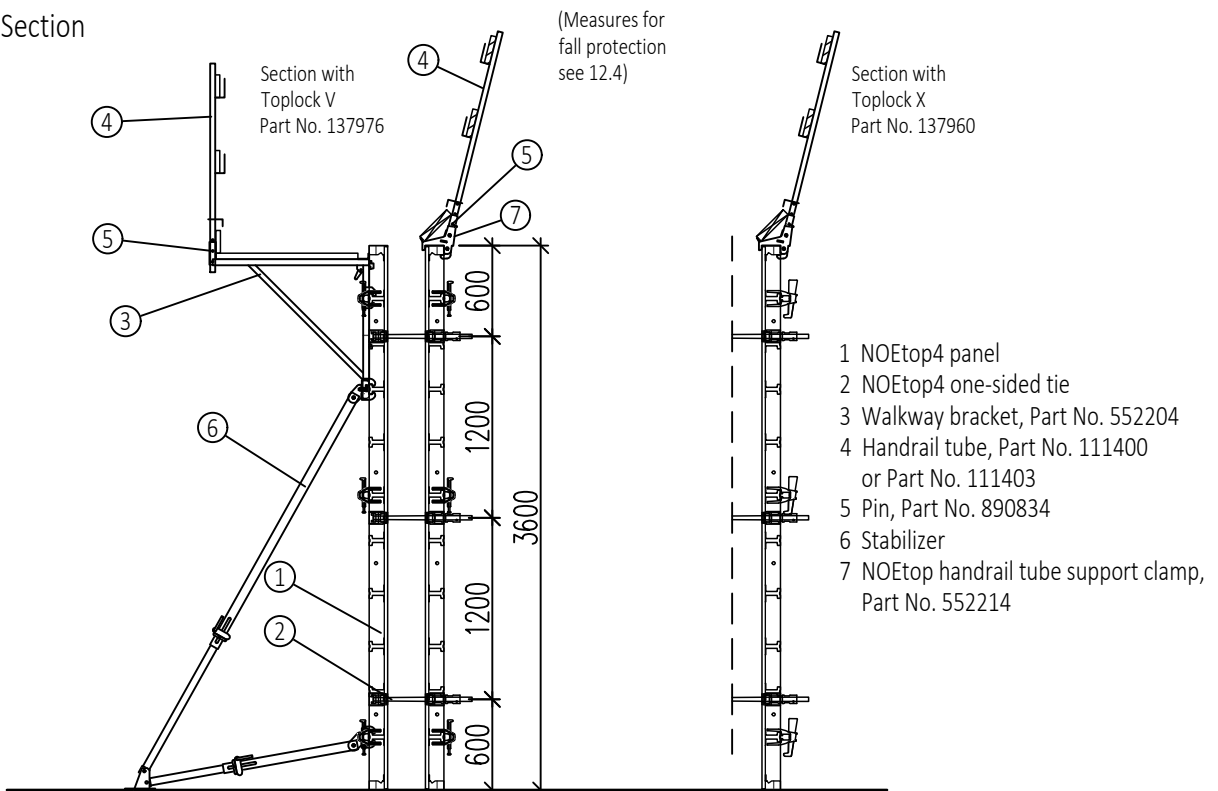

5. Element connections

(Ties not shown - see Chapter 6)

5.1 Connection with NOE Toplock V - with up to 42 mm compensation piece

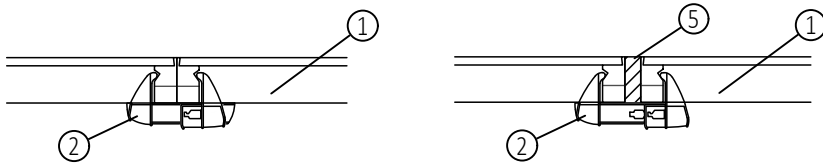

The NOE Toplock can be used on panel butt joints with a 0-42 mm compensation piece.

5.2 Connection with NOE Toplock X - with a compensation piece of up to 100 mm

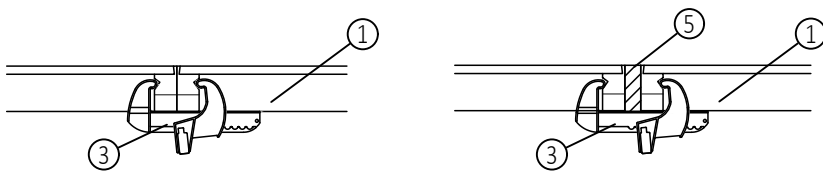

The NOE Toplock X be used at a panel butt joint with a 0-100 mm compensation piece.

5.2 Connection with NOE Easylock - compensation piece cannot be used

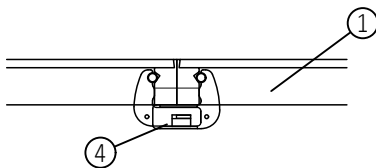

NOE Easylock can be used at panel butt joints to connect elements. Compensation pieces cannot be used.

5.4 Element connection with longitudinal tension forces

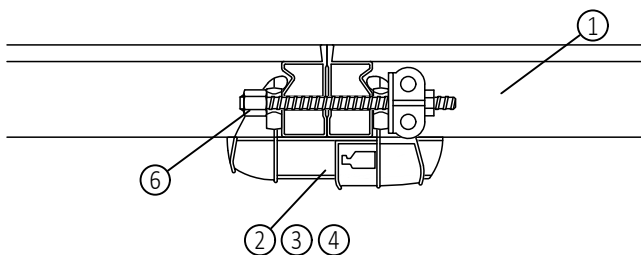

If longitudinal compensation is required, replace the connection bolt by a threaded rod and additional sprint nut

- 1 NOEtop4 panel
- 2 NOE Toplock V, Part No. 137976
- 3 NOE Toplock X, Part No. 137960
- 4 NOE Easylock, Part No. 137950
- 5 Timber compensation piece

- 6 Connection bolt, Part No. 135019 with 2 x waling plates, Part No. 691500 and Sprint nut, Part No. 680580 or with compensation piece tie rod, 2x plates and 2x Sprint nuts

5.5 Using the Toplock V

- ◆ The panels must be butted together as closely as possible. Push the opened panel lock horizontally over the panel butt joint whilst lifting the wedge slightly with the fingers. Place the fixed shoe on to the frame of the panel.
- ◆ Push the mobile shoe to close it, until it lies against the profile. Release the wedge to fix the lock and press it downwards.
- ◆ Drive the wedge in with the hammer.

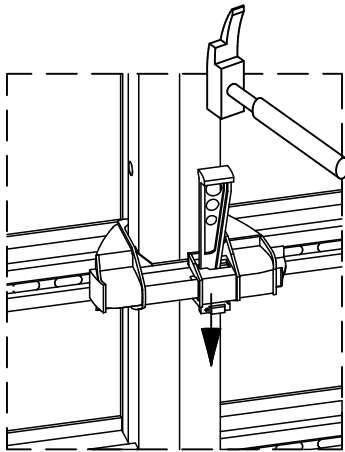
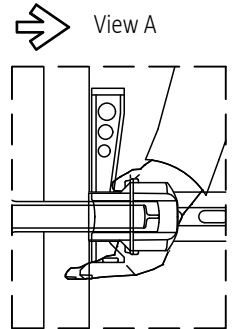
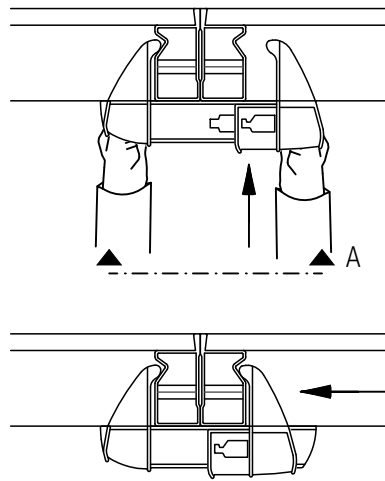

5.6 Connections with alignment clamps - with extensions

Extension with end-on panels

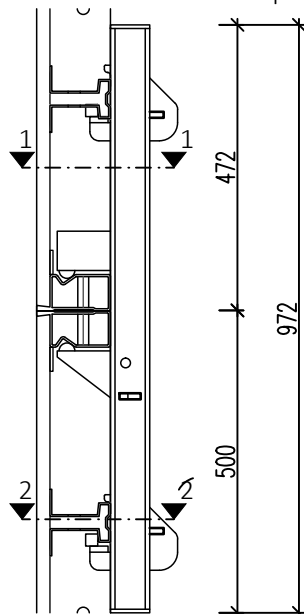

Section 1-1

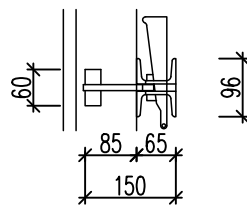

Section 3-3

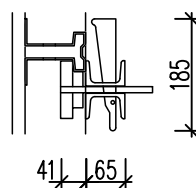

Extension with side-on panels

Section 2-2

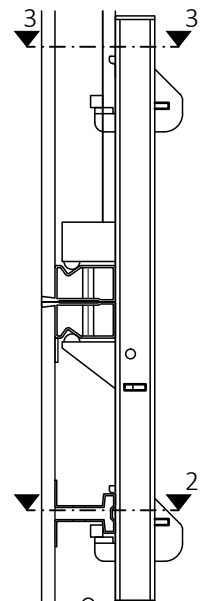
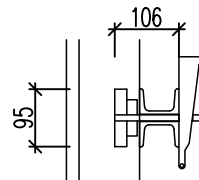

5.6.1 Using the alignment clamps

Connecting to the horizontal profile

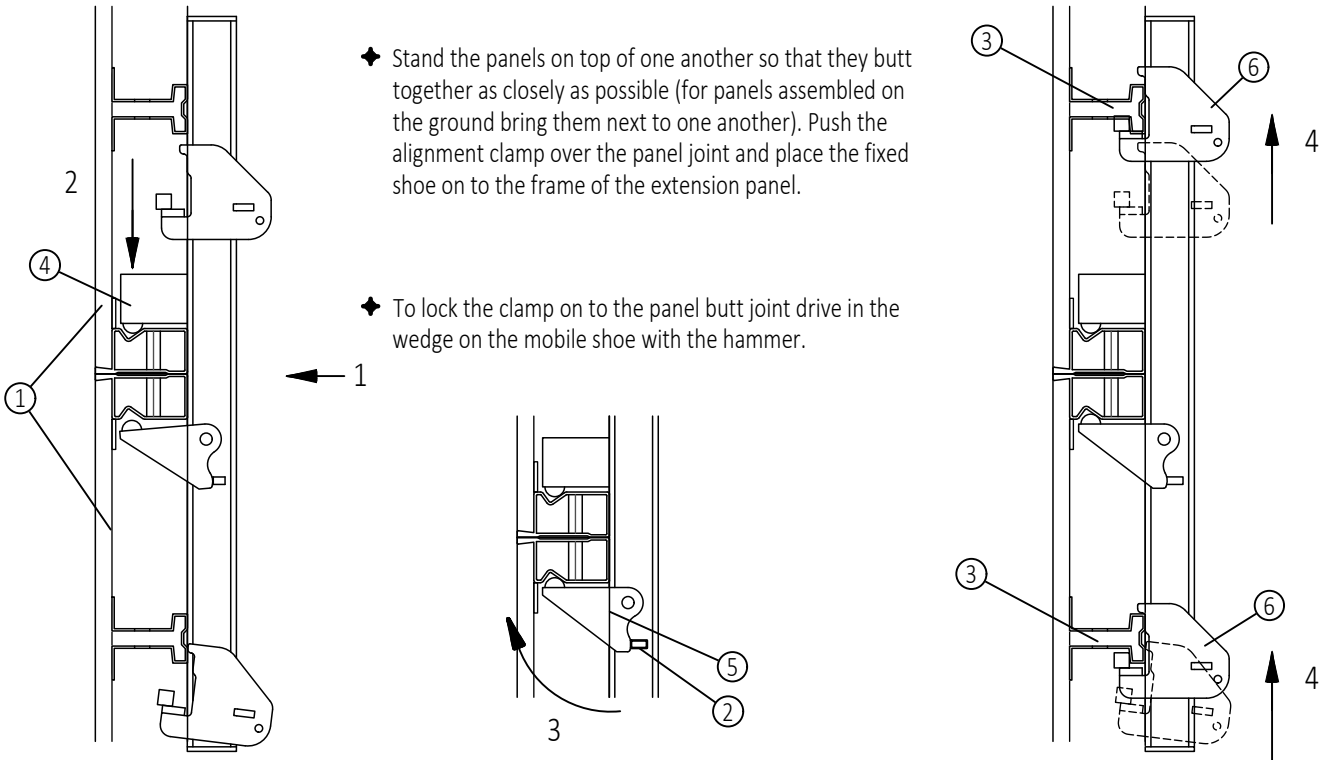

◆ Push each of the two outer mobile shoes on to the hat profile so that they enclose the profile

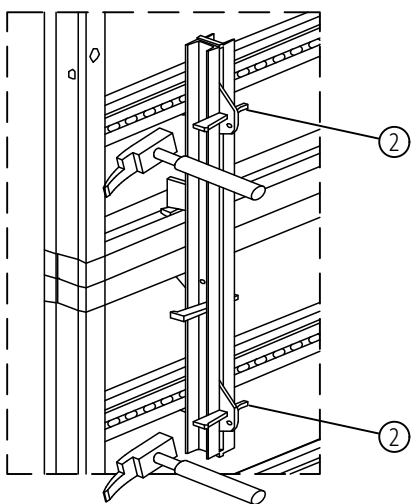

◆ and drive in the wedges with the hammer.

- 1 End-on panel
- 2 Wedge
- 3 Hat profile
- 4 Fixed shoe
- 5 Mobile shoe
- 6 Outside mobile shoe

Connecting to the vertical profile

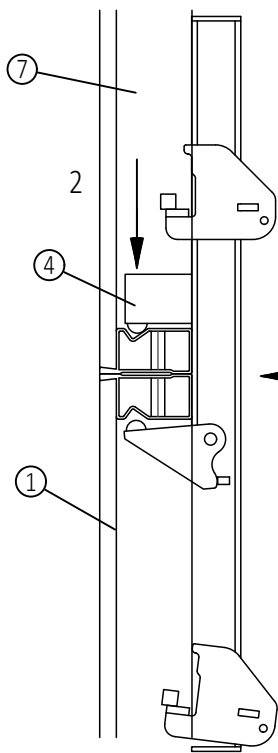

◆ Stand the panels on top of one another so that they butt together as closely as possible (for panels assembled on the ground bring them next to one another). Push the alignment clamp over the panel joint and place the fixed shoe on to the frame of the extension panel. Pay particular attention to ensuring that the clamp is close enough to the hat profile of the side-on panel that the nib engages the profile (see below).

◆ To lock the clamp on to the panel butt joint drive in the wedge on the mobile shoe with the hammer.

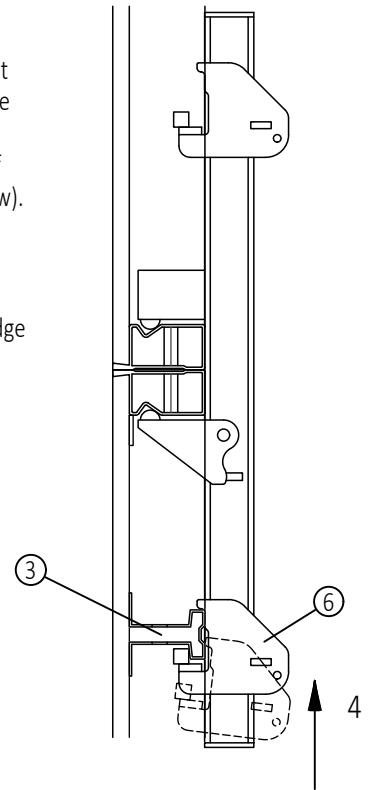
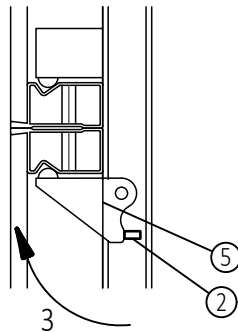

◆ Push the bottom mobile shoe on to the hat profile so that it encloses the profile then drive in the wedge.

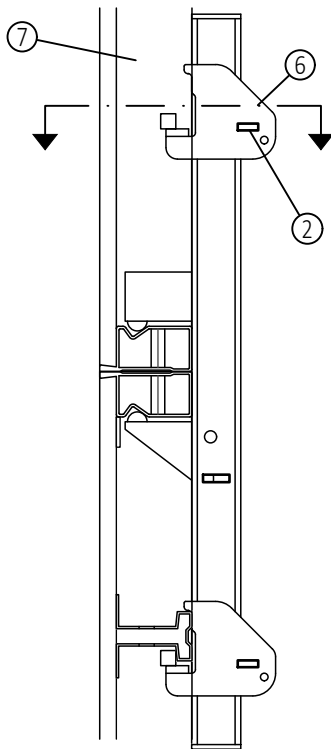

The bottom shoe is attached on the case of 2 side-on panels as described above.

◆ With the top shoe, pay particular attention to ensure that the pin engages in the hat profile of the side-on panel and then drive in the wedge.

Section through top mobile shoe and hat profile of the side-on panel

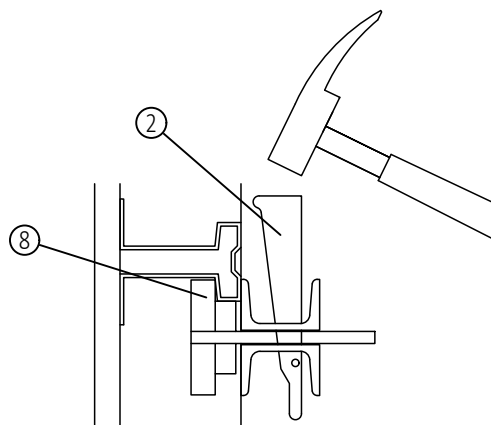

- 1 Standing panel
- 2 Wedge
- 3 Hat profile
- 4 Fixed shoe
- 5 Mobile shoe
- 6 Outside mobile shoe
- 7 Side-on panel
- 8 Pin

5.7 Using the Toplock X

- ◆ The panels must be butted together as closely as possible. Fully open the panel lock.

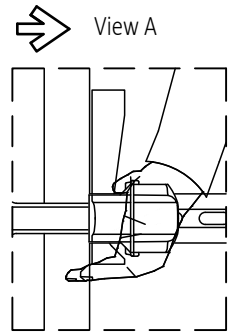
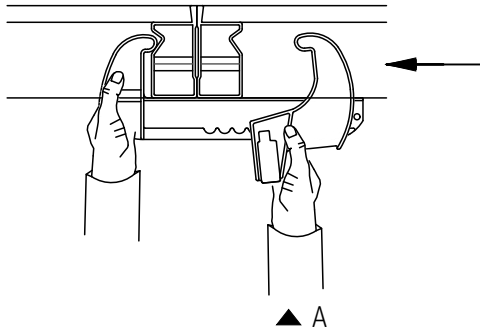

- ◆ Push the opened panel lock horizontally over the panel butt joint whilst lifting the wedge slightly with the fingers. Place the fixed shoe on to the frame of the panel.

- ◆ Push the mobile shoe to close it, until it lies against the profile. Release the wedge to fix the lock and press it downwards.

- ◆ Drive the wedge in with the hammer.

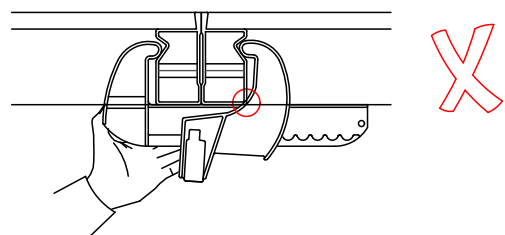
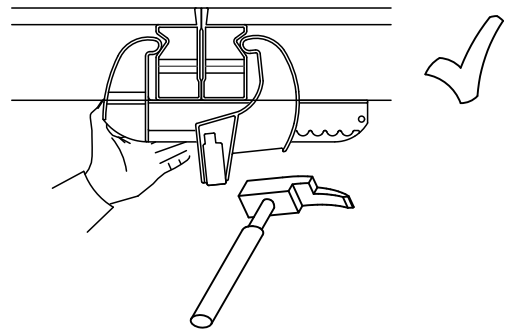
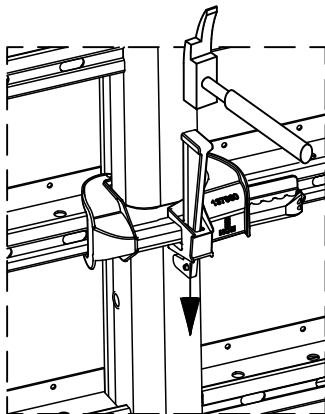

Number of Toplock X

	Panel height [mm]	Number high
	3600 mm	3
	3000 mm	3
	900 mm	1

→ For cross-sectional view see 4.1 and 4.2

In areas where there are high tension forces (corners, stopends, etc.) an increased the number of connections must be used



6. One-sided tie system - NOEtop4

6.1 Setting the wall thickness

Fitting the adjuster nut

- ◆ Push the adjuster nut over the tapering tie rod

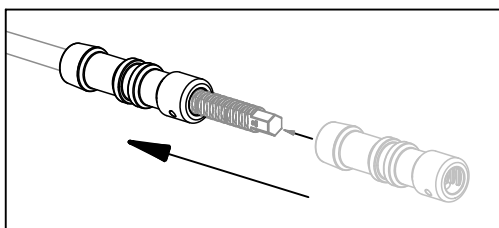

- ◆ Bring the anchor rod into the locking position by turning it through 90°

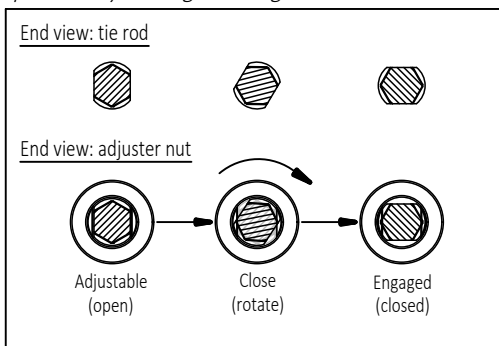

- ◆ Push the locking clip through the opening in the adjuster nut and turn it downwards over the adjuster nut

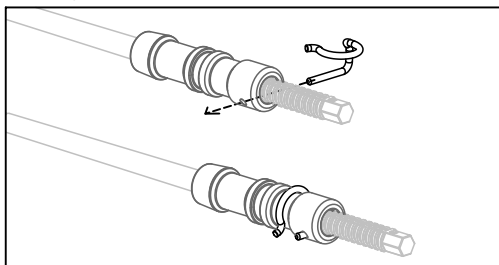

Check dimension - wall thickness

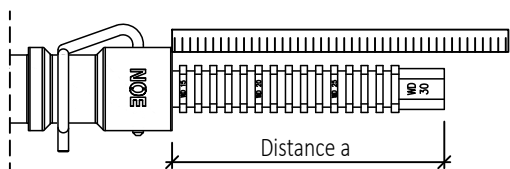

Wall thickness		Distance a
Rod A	Rod B	
150 mm	250 mm	180 mm
200 mm	300 mm	130 mm
250 mm	350 mm	80 mm
300 mm	400 mm	30 mm



NOEtop4 - tie rods DW20 have an adjustable wall thickness setting of +/- 1cm

NOEtop4 - tie rod DW20
Wall thicknesses of 15 - 30 cm (rod A)

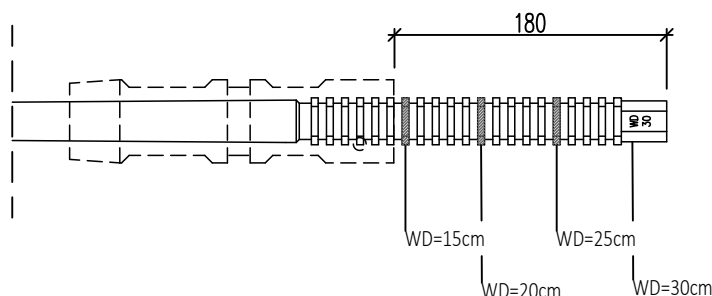

NOEtop4 - tie rod DW20
Wall thicknesses of 25 - 40 cm (rod B)

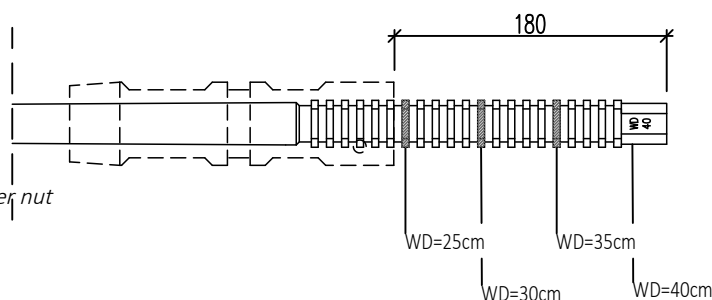

Example - one-sided tie
Wall thickness = 25 cm (rod A)

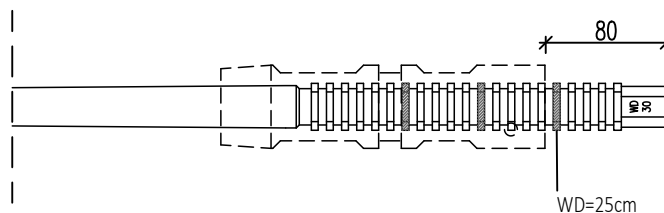

For wall thicknesses of 15 - 30 cm

Part No. 850008

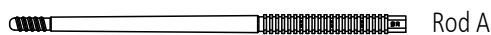

For wall thicknesses of 25 - 40 cm

Part No. 850009



NOEtop4 Formwork

6.2 Preparation of the first-face formwork

◆ *FIRST-FACE FORMWORK - insert fixed bearing*

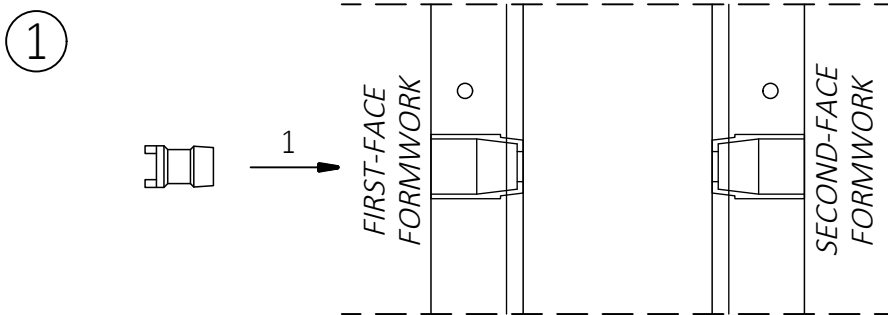

◆ *FIRST-FACE FORMWORK - secure fixed bearing with securing pin + spring pin*

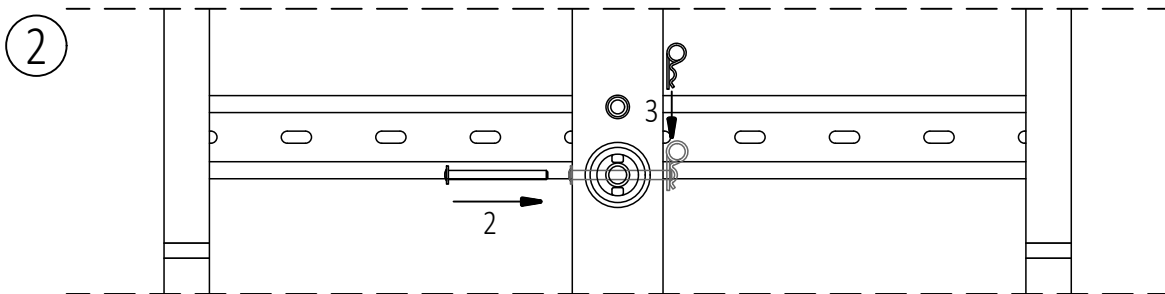

6.3 Closing the formwork / erection

◆ *SECOND-FACE FORMWORK - setting the distance preserver*

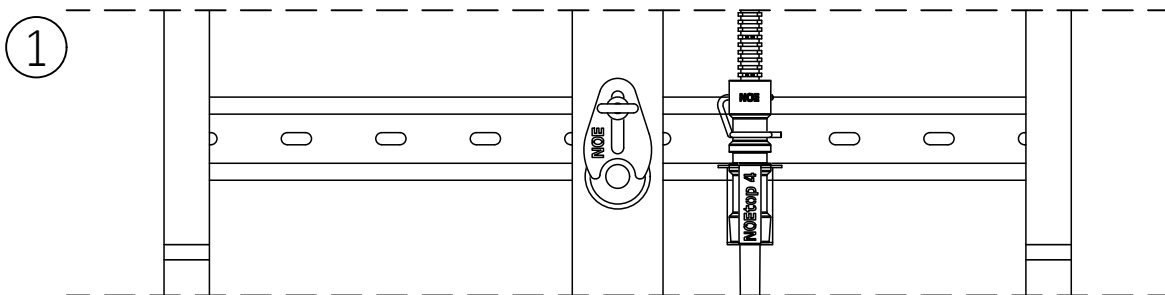

◆ *SECOND-FACE FORMWORK - screw in the distance preserver with the ring bolt*

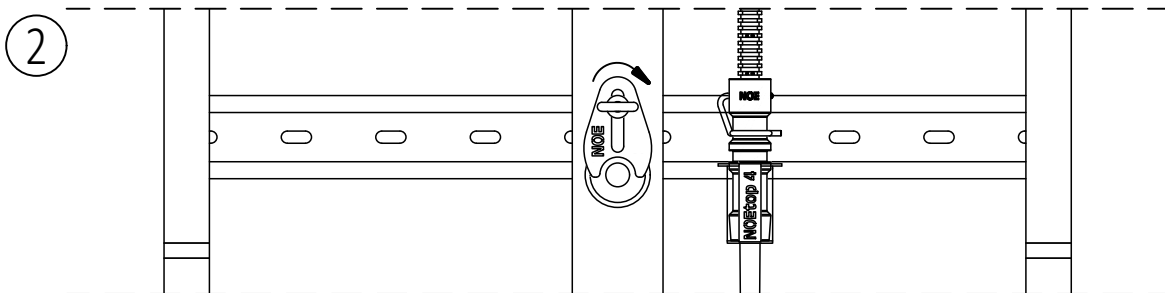

◆ *SECOND-FACE FORMWORK - release ring bolt and push up distance preserver*

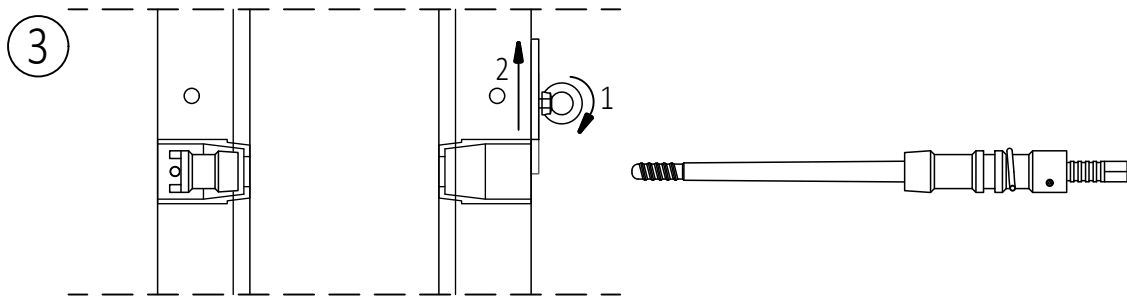

◆ *SECOND-FACE FORMWORK - lubricate tapered tie rod DW20 with release agent and insert*

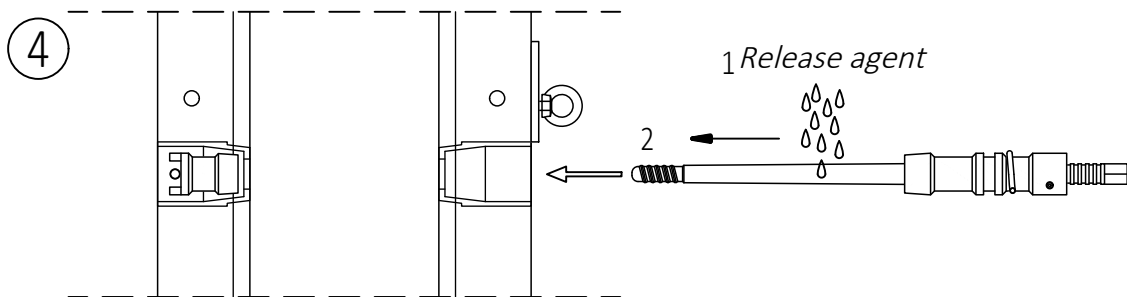

◆ *SECOND-FACE FORMWORK - screw the tapered tie rod DW20 into the fixed bearing, as far as it will go. Ensure rod is only hand-tight!*

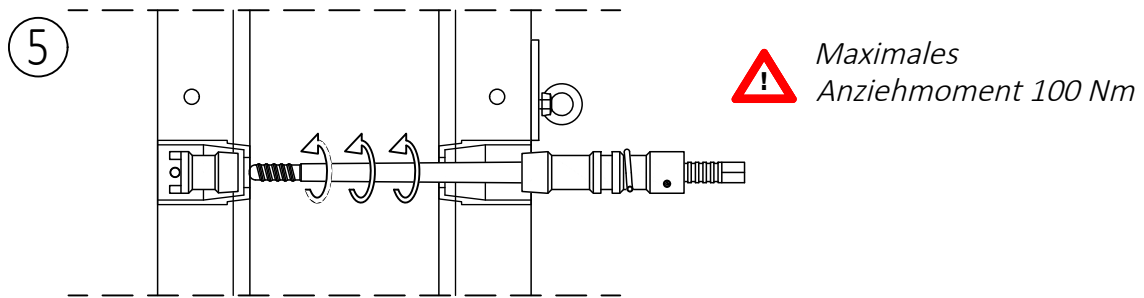

◆ *SECOND-FACE FORMWORK - push distance preserver downwards and secure with the ring bolt*

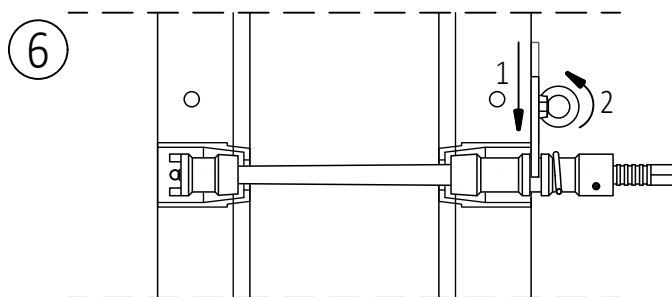

6.4 Sealing the unused tie rod holes

Unused tie rod holes must be sealed with sealing pins !

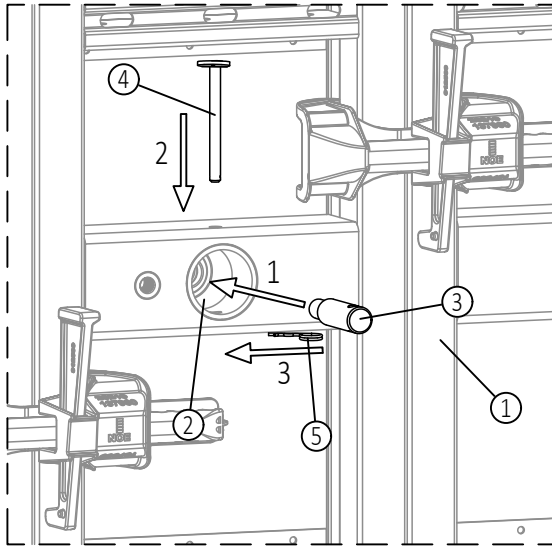

1. Insert sealing pin into the bearing shell as far as it will go
2. Insert the securing pin through the opening in the bracing profile
3. Secure the securing pin with the spring pin

Section through panel

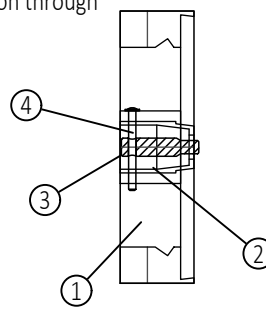

View on side



- 1 NOEtop4 - panel
- 2 NOEtop4 - bearing shell
- 3 NOEtop4 - sealing pin, Part No. 928012
- 4 NOEtop4 - securing pin, Part No. 850012
- 5 Spring pin, Part No. 913303

6.5 Removing the ties / stripping

◆ *SECOND-FACE FORMWORK - release ring bolt and push up distance preserver*

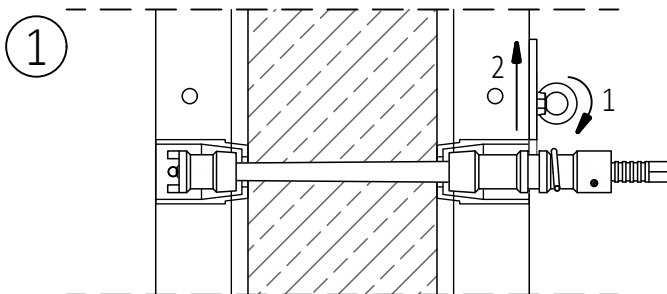

Remove tapered tie rod DW20 - as early as possible, to prevent it adhering to the concrete

◆ *SECOND-FACE FORMWORK - screw out tapering tie rod*

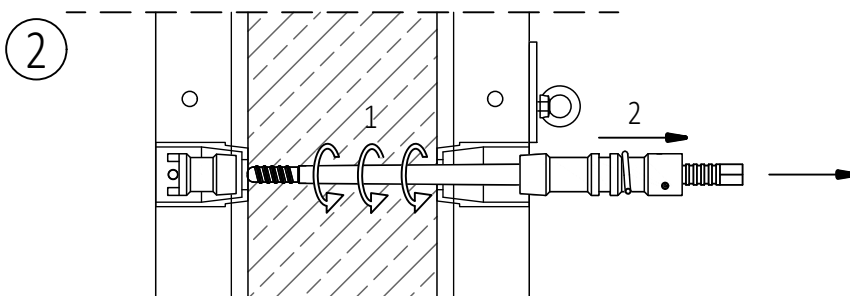



7. Corner solutions

7.1 Corner 90° - with NOEtop4 external corner 150 x 150 mm

◆ External corner clamped

⇒ Wall thicknesses up to 300 mm
Wall heights up to 3600 mm

Seal the tie rod holes of the corner panels with sealing pins!
→ For installation see section 6.4

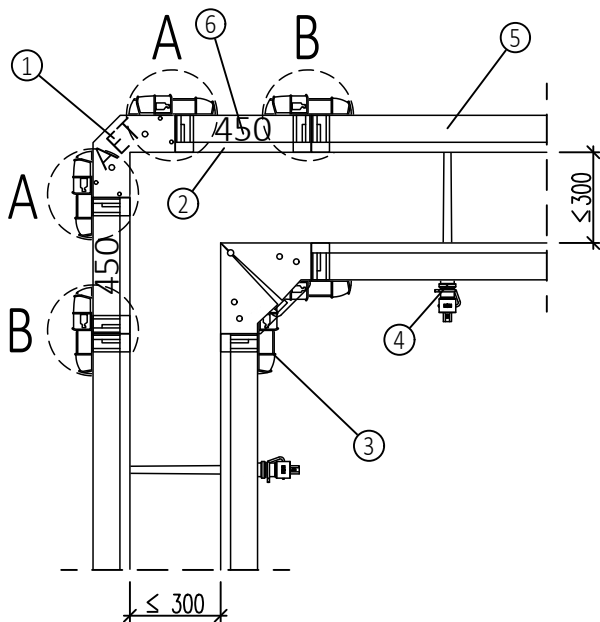
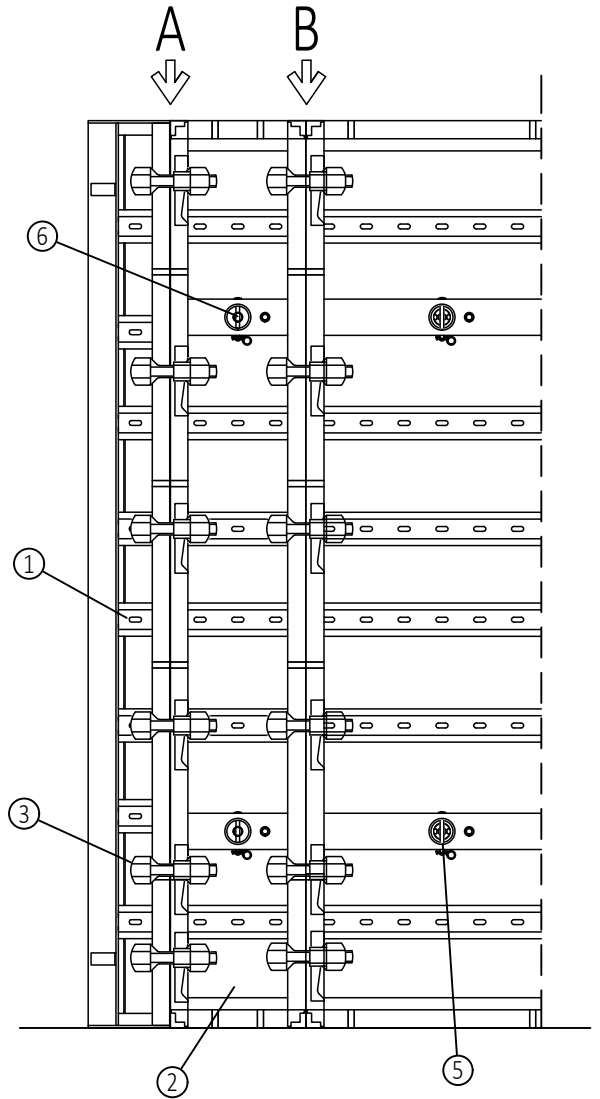
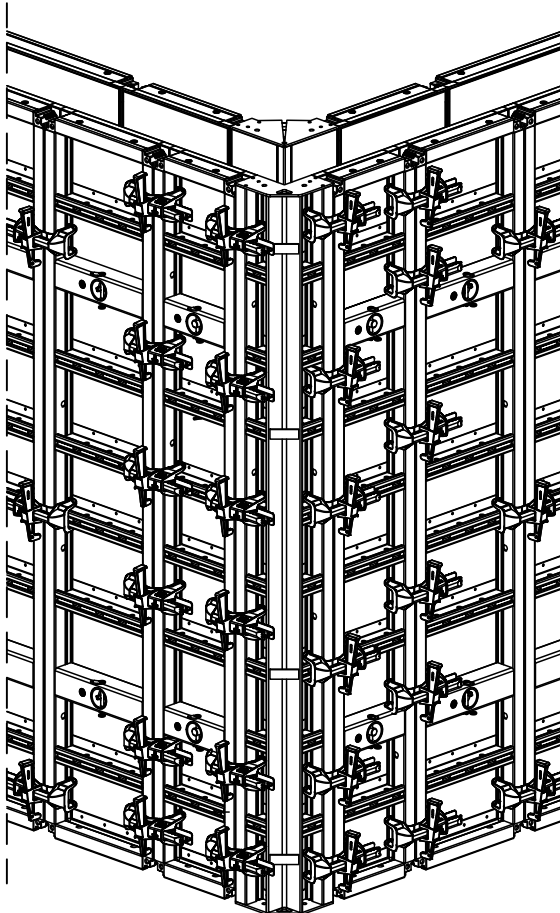

- 1 NOEtop4 - external corner 150x150 mm
- 2 NOEtop4 - make-up panel
- 3 NOE Toplock V, Part No. 137976
- 4 NOEtop4 - one-sided tie
- 5 NOEtop4 - fixed bearing, Part No. 850007
- 6 NOEtop4 - sealing pin, Part No. 928012

Number of connections			
	Panel height [mm]	Number high	
		Butt joint A	Butt joint B
	3600 mm	6	6
	3000 mm	6	6
	900 mm	2	2

◆ External corner clamped

⇒ Wall thicknesses from 300 mm to 400 mm
Wall heights from 3600 mm

☞ Seal the tie rod holes of the corner panels with sealing pins!
⇒ For installation see section 6.4

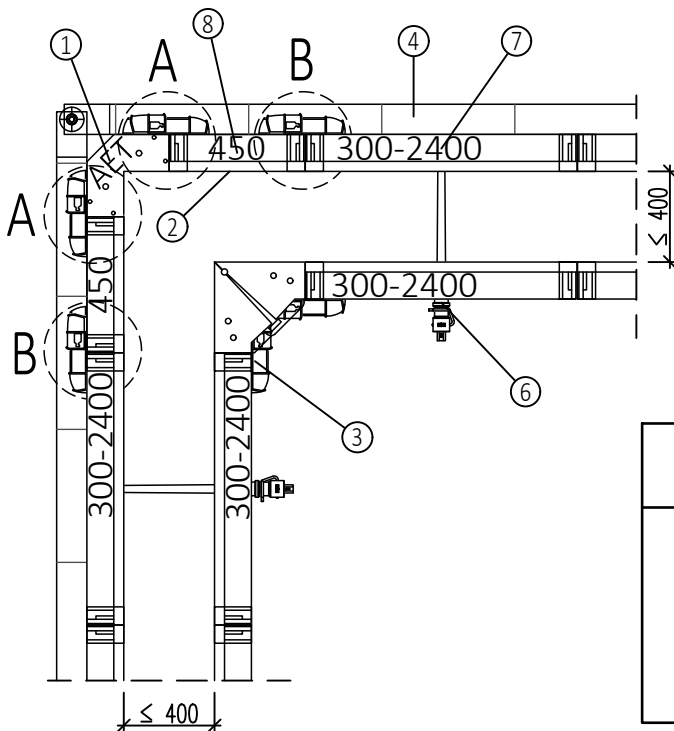
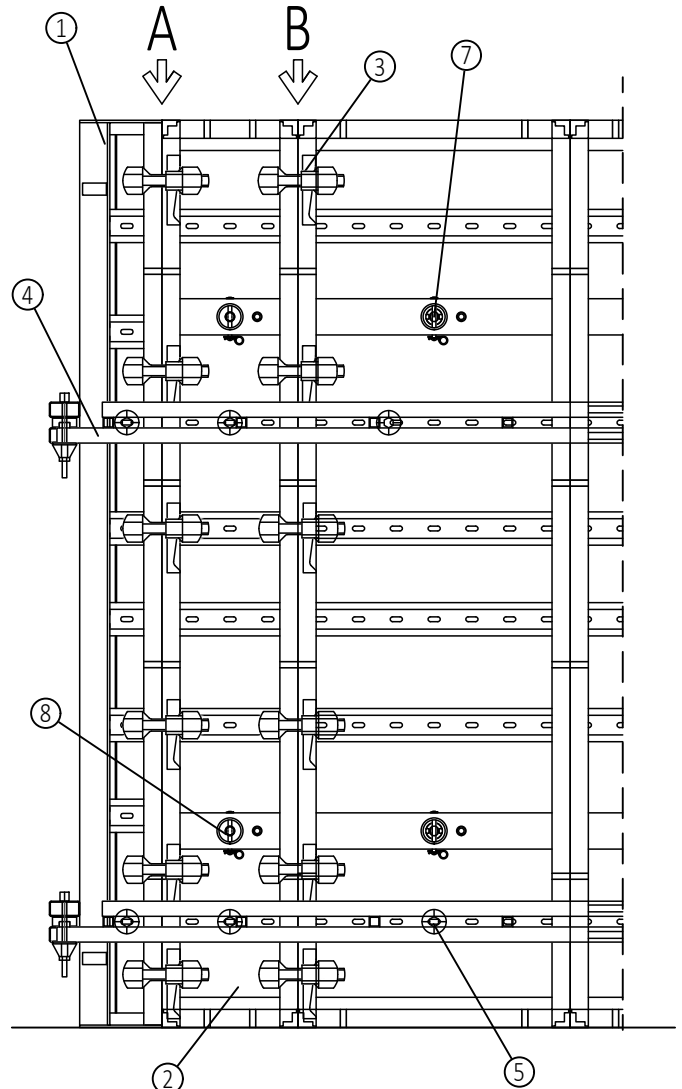
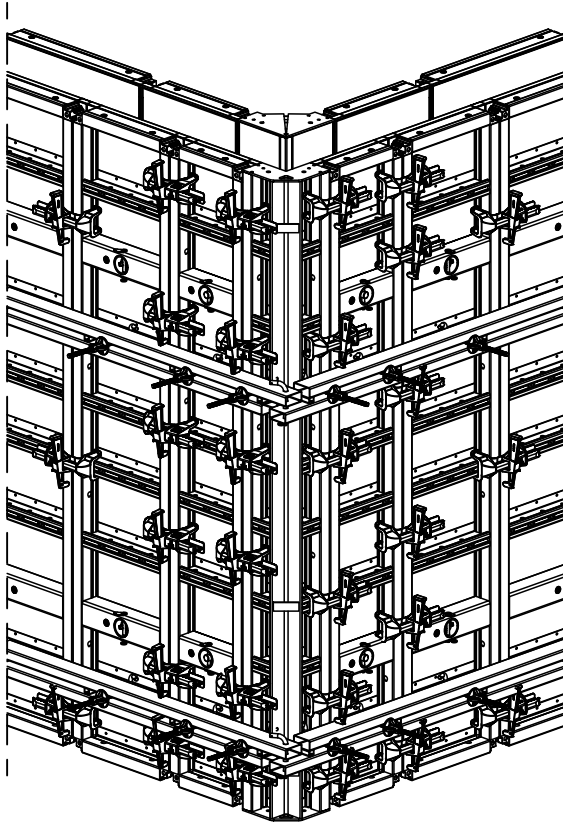

- 1 NOEtop4 - external corner 150x150 mm
- 2 NOEtop4 - make-up panel
- 3 NOE Toplock V, Part No. 137976
- 4 NOEtop4 - alignment channel, Part No. 850039
- 5 NOEtop4 - tie rod with fixing lug, Part No. 850014
- 6 NOEtop4 - one-sided tie
- 7 NOEtop4 - fixed bearing, Part No. 850007
- 8 NOEtop4 - sealing pin, Part No. 928012

Number of connections				
☞	Panel height [mm]	Number high		
		Butt joint A	Butt joint B	Bracings
	3600 mm	6	6	3
	3000 mm	6	6	2
	900 mm	1	1	1



7.2 Corner 90° - with NOEtop4 external corner angle

◆ External corner angle clamped or bolted

Seal the tie rod holes of the corner panels with sealing pins!
 For installation see section 6.4

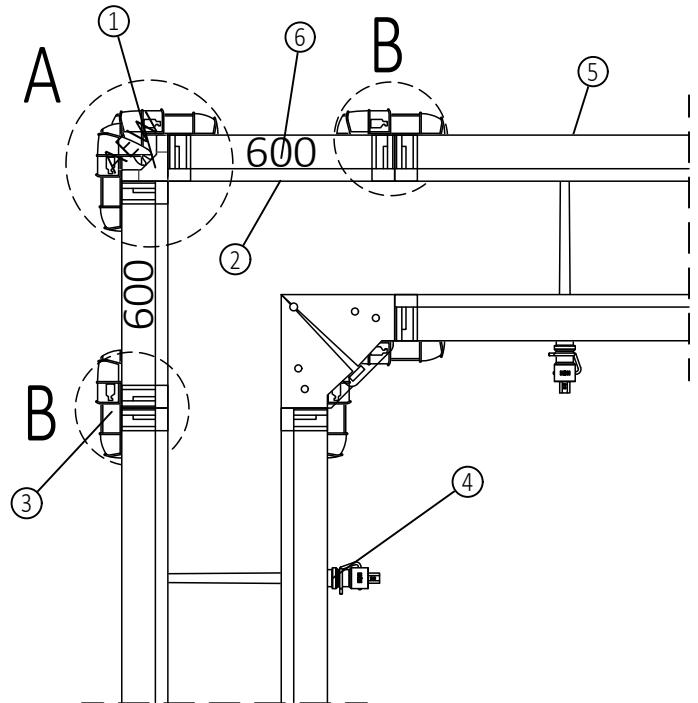
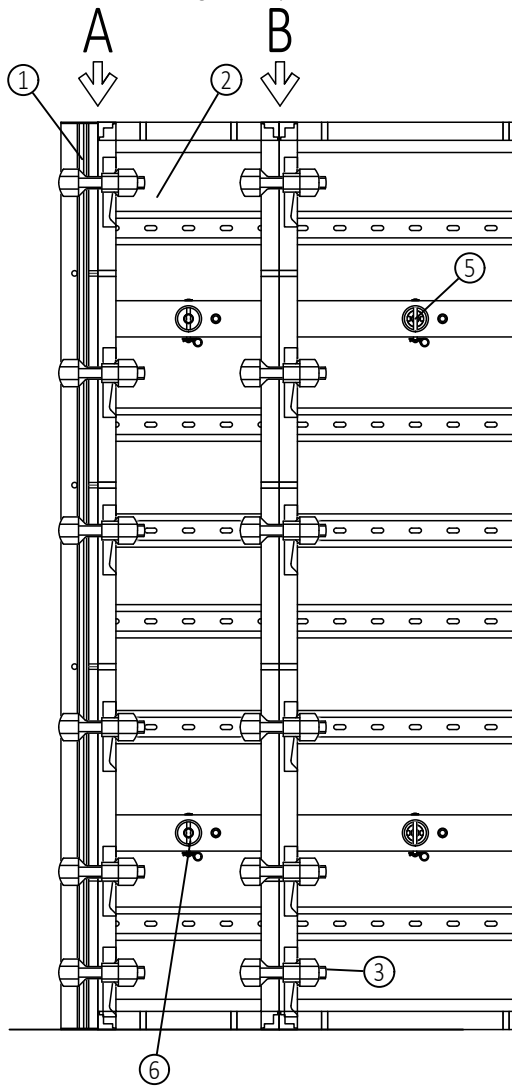

◆ Detail Bolted connection NOEtop4 - ECA

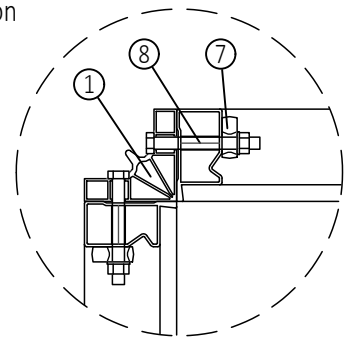

Number of connections					
	Panel height [mm]	Number high			Butt joint B
		Butt joint A Locks	— or —	Butt joint A Bolts	
	3600 mm	6	— or —	4	6
3000 mm	6	— or —	4	6	
900 mm	2	— or —	2	2	

- 1 NOEtop4 - external corner angle ECA
- 2 NOEtop4 - make-up panel
- 3 NOE Toplock V, Part No. 137976
- 4 NOEtop4 - one-sided tie
- 5 NOEtop4 - fixed bearing, Part No. 850007
- 6 NOEtop4 - sealing pin, Part No. 928012
- 7 Waling plate, Part No. 691500
- 8 M16x140, Part No. 314250

7.3 Corners 90° with compensation piece

7.3.1 Corner 90° - with NOEtop4 external corner 150 x 150 mm

⇒ Wall thicknesses from 150 to 200 mm

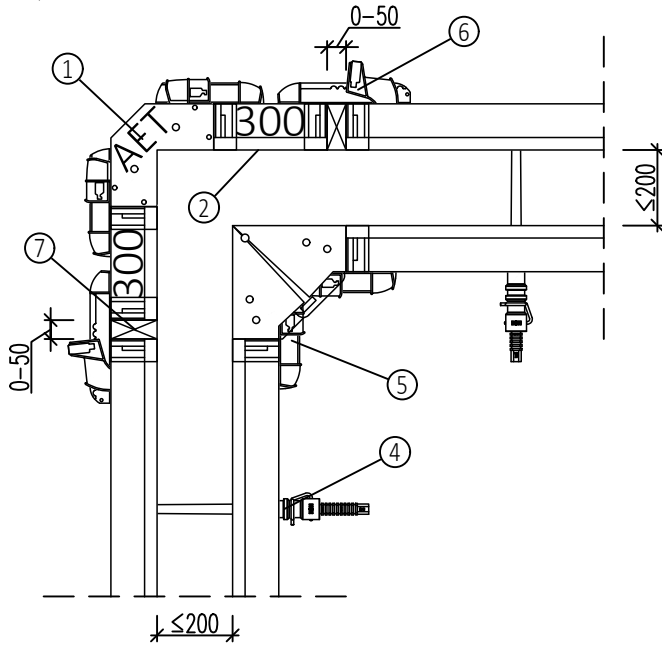

⇒ Wall thicknesses from 200 to 300 mm

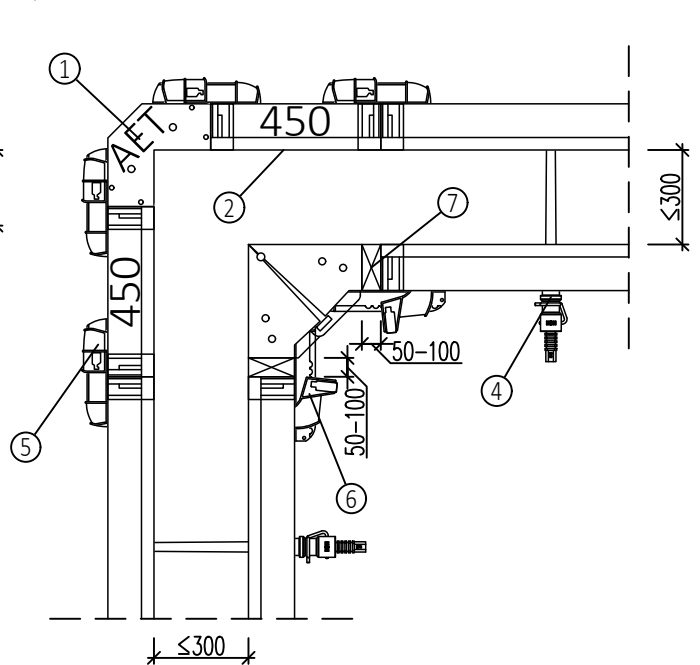

⇒ Wall thicknesses from 300 to 350 mm

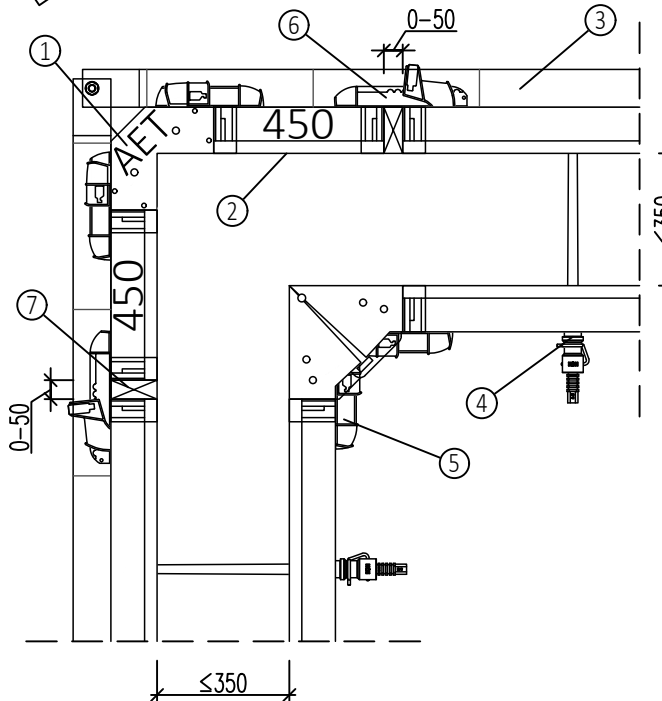

⇒ Wall thicknesses from 350 to 400 mm

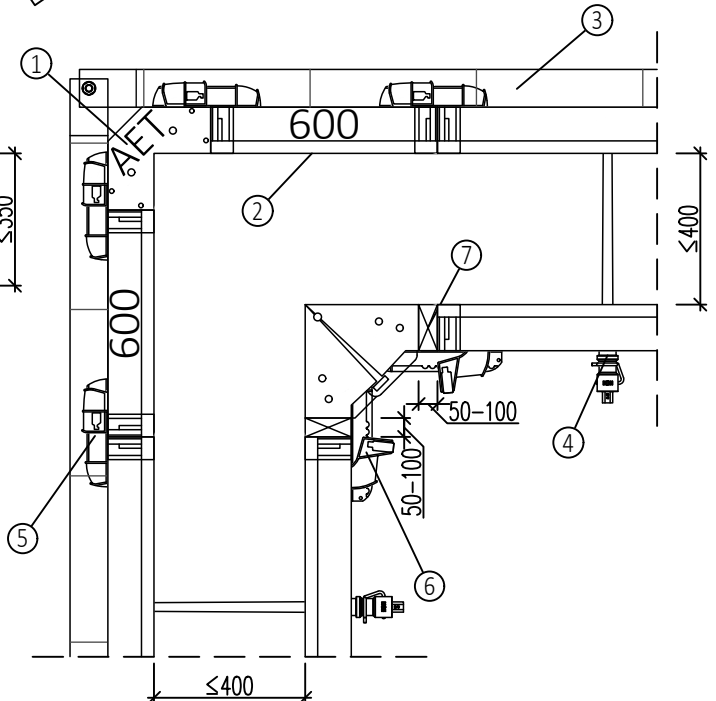

Set compensation pieces as far inward as possible !

- | | |
|--|----------------------------------|
| 1 NOEtop4 - external corner 150 x 150 mm | 5 NOE Toplock V, Part No. 137976 |
| 2 NOEtop4 - make-up panel | 6 NOE Toplock X, Part No. 137960 |
| 3 NOEtop4 - alignment channel 2100 mm | 7 Timber compensation piece |
| 4 NOEtop4 - one-sided tie | |

7.3.2 Corner 90° - with NOEtop4 external corner angle

⇒ Wall thicknesses from 150 to 200 mm

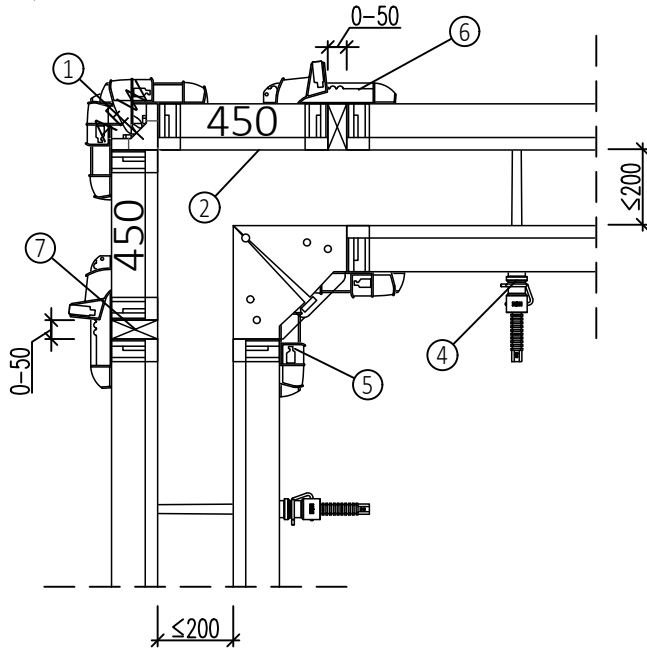

⇒ Wall thicknesses from 200 to 300 mm

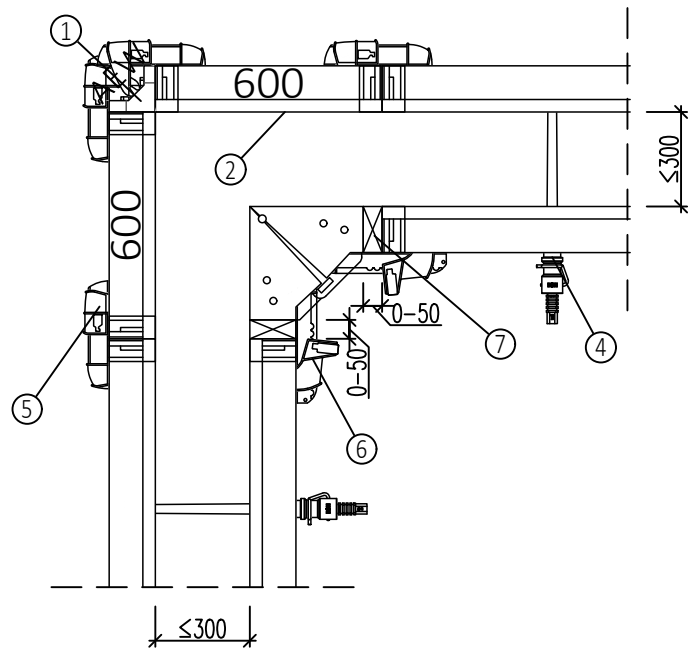

⇒ Wall thicknesses from 300 to 350 mm

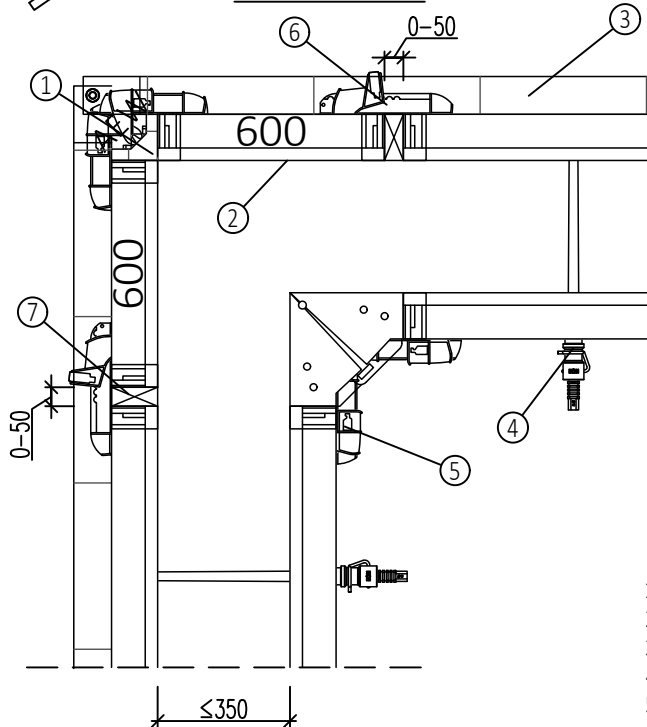

Detail
Connection of NOEtop4 alignment channel 2100 mm

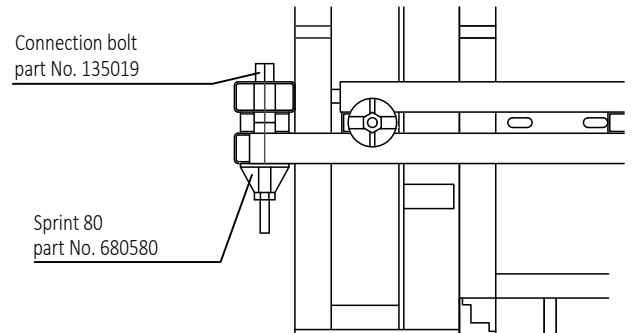

- 1 NOEtop4 - external corner angle ECA
- 2 NOEtop4 - make-up panel
- 3 NOEtop4 - alignment channel 2100 mm
- 4 NOEtop4 - one-sided tie
- 5 NOE Toplock V, Part No. 137976
- 6 NOE Toplock X, Part No. 137960
- 7 Timber compensation piece

Set compensation pieces as far inward as possible !

7.4 Corner 90° - stripping internal corners

The angle of the internal corner element can be reduced for stripping formwork.

Corner with formwork in place

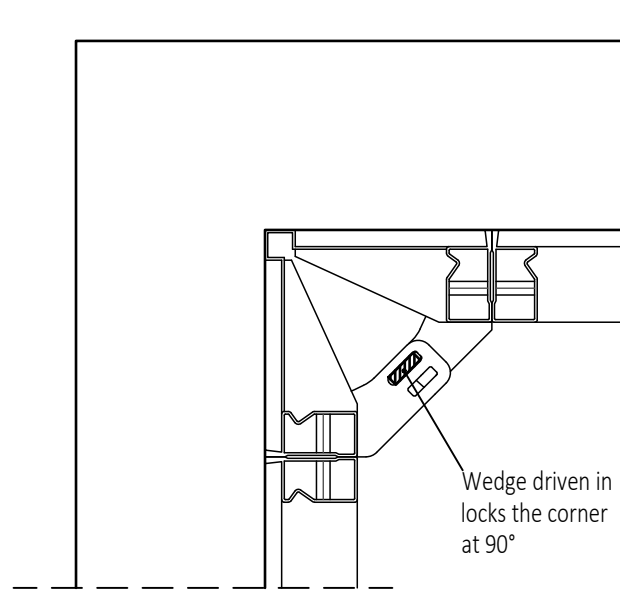

Corner being stripped

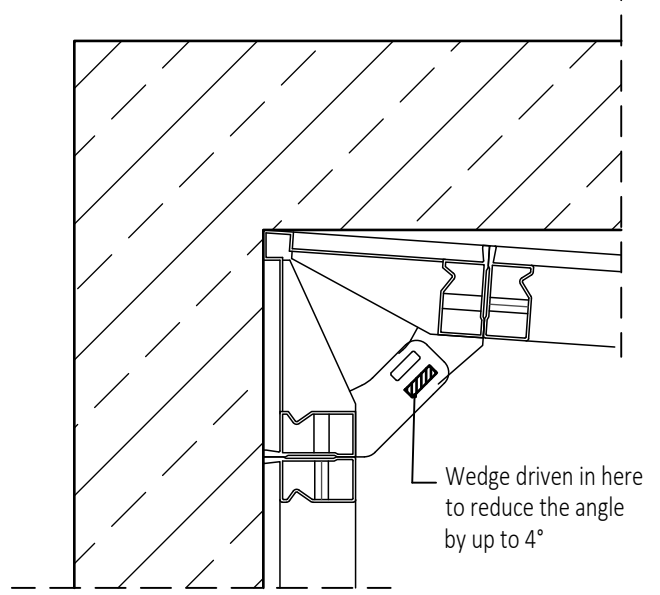

8. Stop-end formwork

Following panels to be clamped with increased numbers of locks as to take the horizontal forces from the stop-end; this applies particularly to smaller sized panels (see 9 about tension forces at external corners).

◆ With connection bolts through the transverse holes in the edge profile

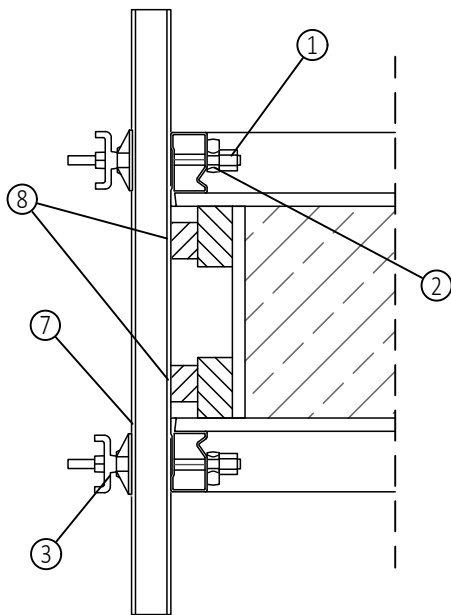

◆ With stop-end holder Part No. 164032 at edge profile independent of transverse holes.

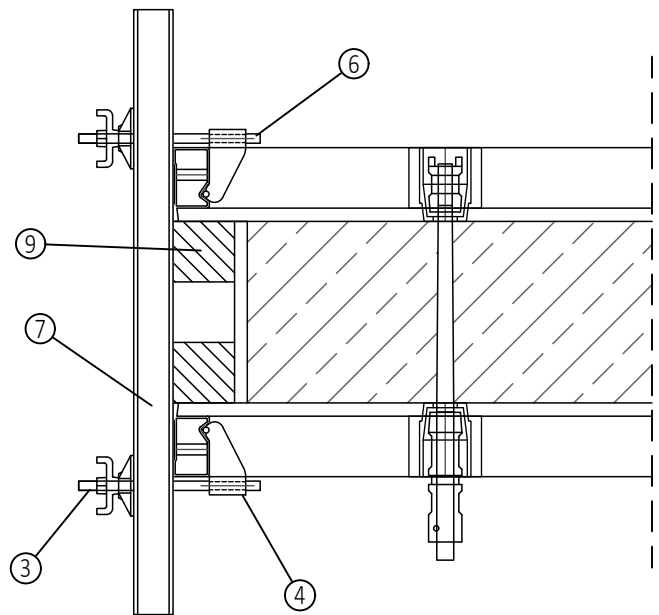

Number of extension channels			
	Panel height [mm]	Number of extension channels high	Max. wall thickness [mm]
	3600 mm	4	300
		5	500
	3000 mm	3	400
4		500	
900 mm	2	500	

◆ With stop-end holder Part No. 164036 at edge profile independent of transverse holes.

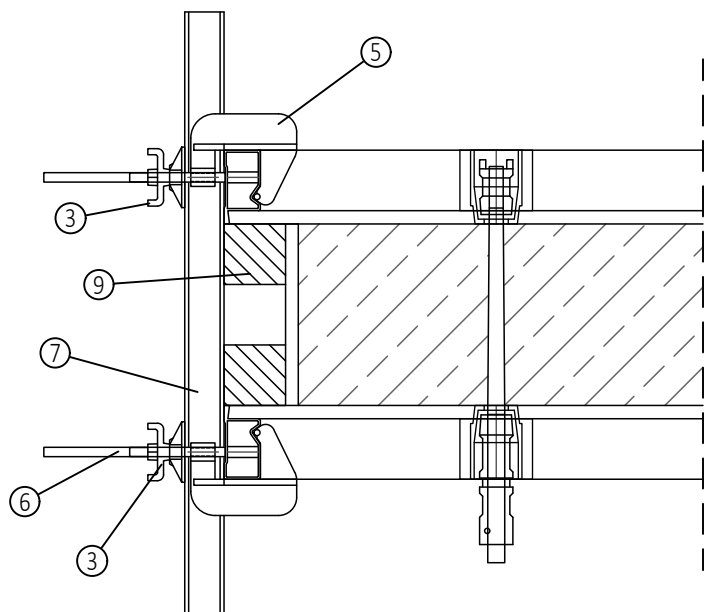

- 1 Connection bolt, Part No. 135019
- 2 Waling plate, Part No. 691500
- 3 Swivel plate with wing nut, Part No. 691700
- 4 Stop-end support 15 kN, Part No. 164032
- 5 Stop-end support 25 kN, Part No. 164036
- 6 Tie rod, Part No. 670300
- 7 Extension channel, Part No. 135208
- 8 Wedge
- 9 Timber - dimensions determined on site

9. Arrangements to transfer tension forces at stopend forms

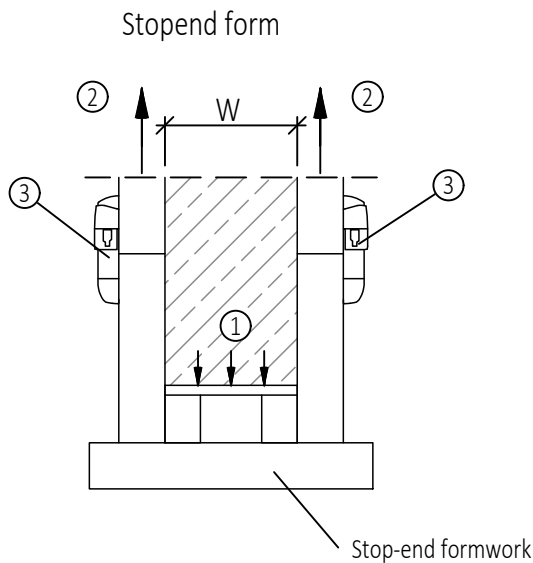

Tables for the number of additional connections to transfer tension forces

Height mm	No. of connections at normal butt joint	W up to 500 mm
		No. of Toplock
3000	3	-
3600	3	-
3900	4	-
4500	4	+1
4800	5	+1
5400	5	+2
6000	6	+2
6600	6	+3
7200	6	+3

- 1 Concrete pressure
- 2 Resulting tension force
- 3 NOE Toplock V

Depending on the concrete pressure and wall thickness more locks (or similar devices) than are necessary for panel connection may be required to transfer the tension forces (see table).

The number of additional connections is given for a concrete pressure of 80 kN/m². Instead of providing the additional number of locks, the panels can also be connected together through transverse holes with the appropriate number of bolts. It may be necessary to connect several panels together in this way.

Further connections will be required for larger wall thicknesses or formwork heights.

10. Formwork connection solutions

10.1 Connection longitudinal to existing wall

with timber

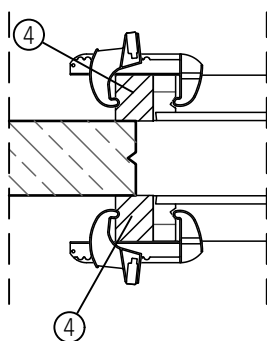

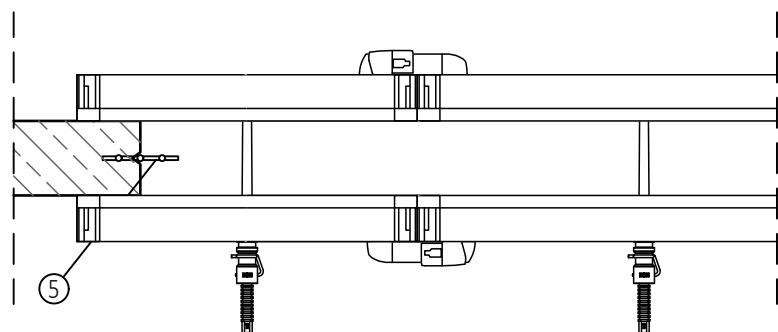

- 4 Squared timber
- 5 Water stop

with NOEtop4
e.g. with water stops





10.2 Connection of T-walls

 Seal any unused tie rod holes with sealing pins!
 For installation see section 6.4

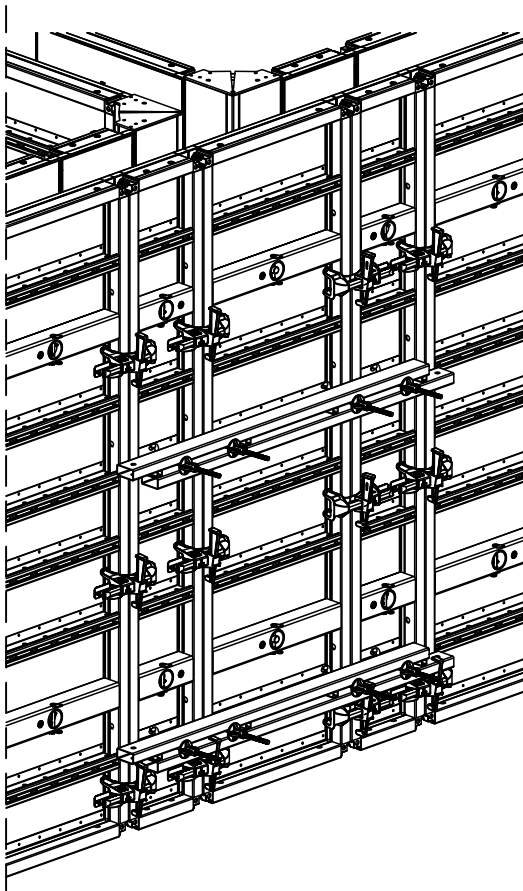

Wall thickness = 250 mm

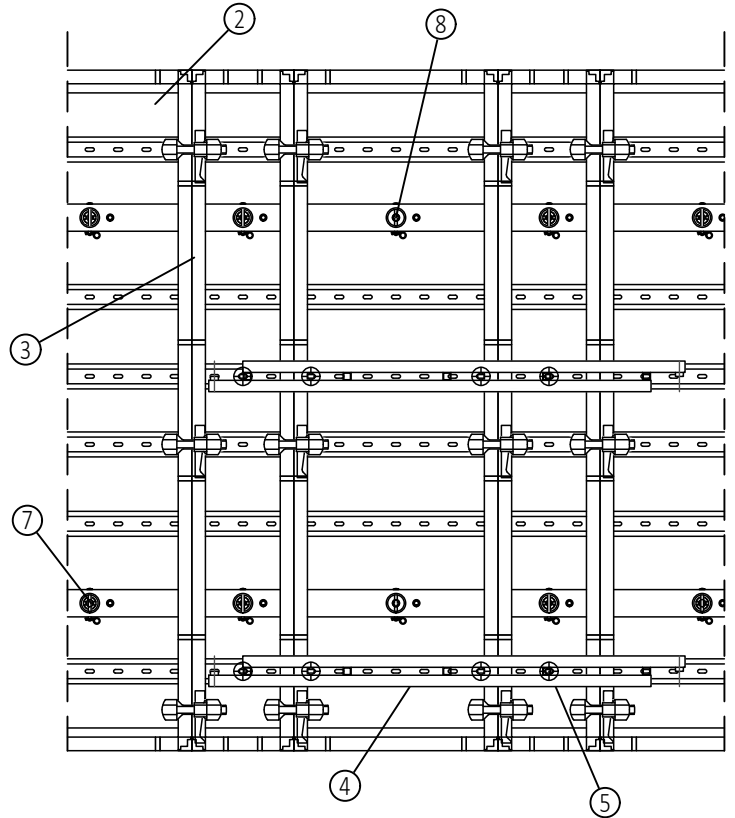

Wall thickness = 300 mm

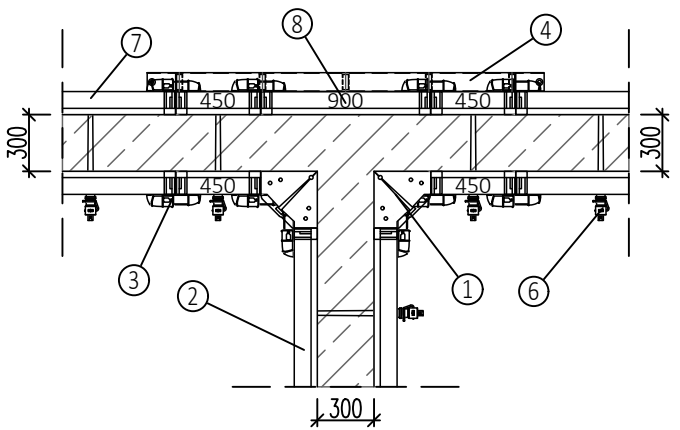
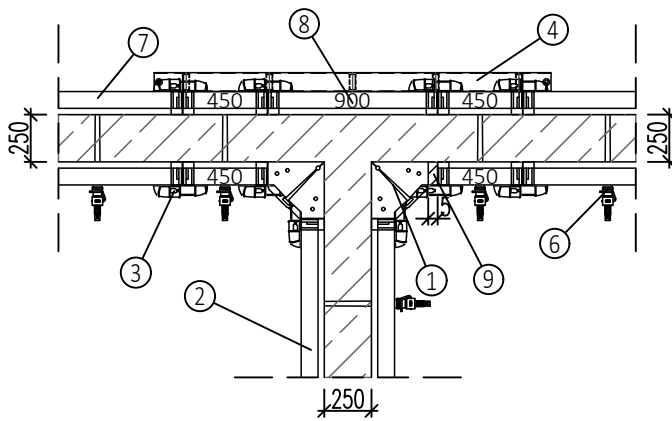

Number of bracings		
	Panel height [mm]	Number of bracings high
	3600 mm	3
	3000 mm	2
900 mm	1	

- 1 NOEtop4 - internal corner 300x300 mm
- 2 NOEtop4 - panel
- 3 NOE Toplock V, Part No. 137976
- 4 NOEtop4 - alignment channel, Part No. 850039
- 5 NOEtop4 - tie rod with fixing lug, Part No. 850014
- 6 NOEtop4 - one-sided tie
- 7 NOEtop4 - fixed bearing, Part No. 850007
- 8 NOEtop4 - sealing pin, Part No. 928012
- 9 Timber compensation piece

10.3 Overview of the NOEtop4 stripping corner

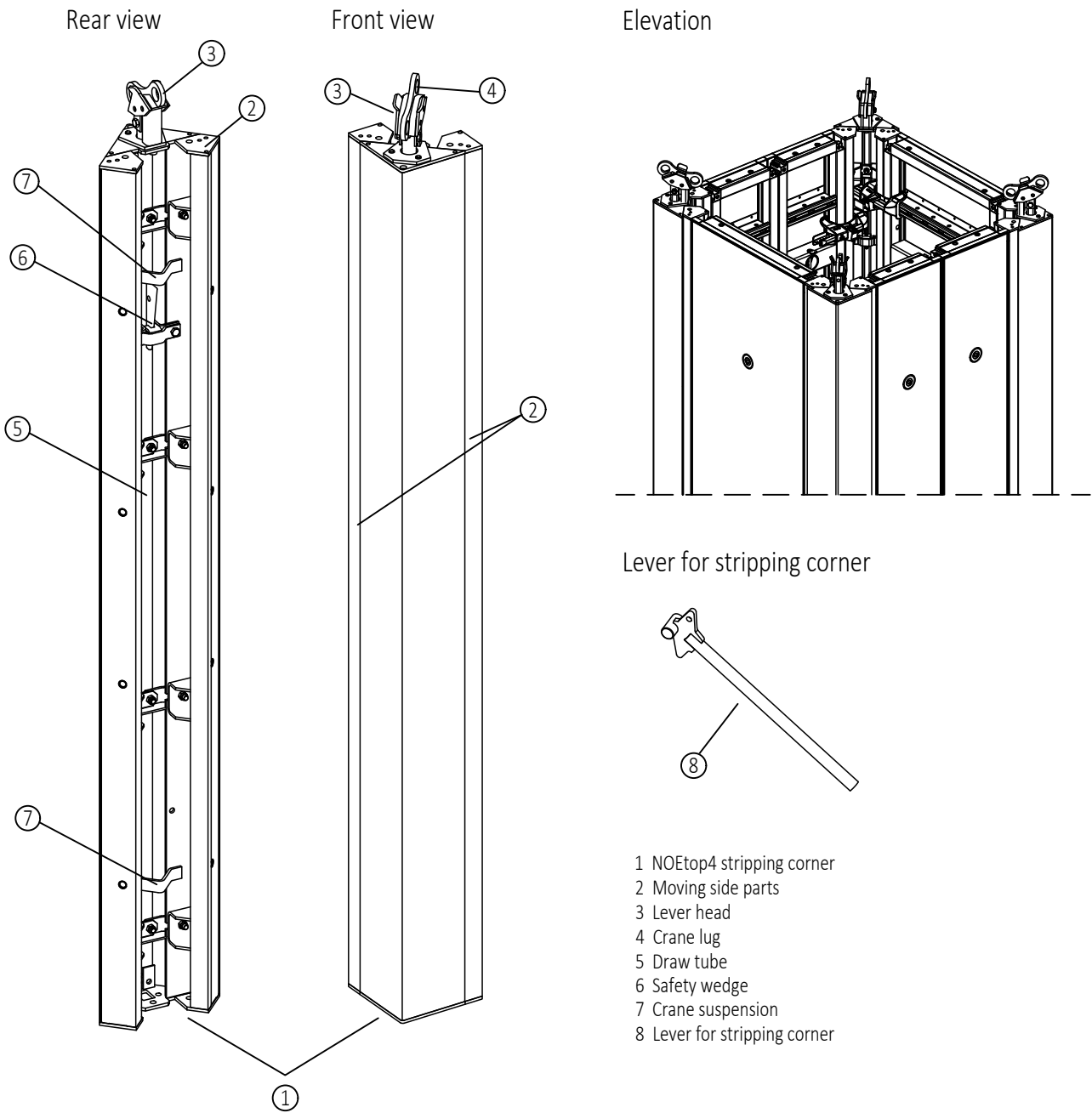

- ⇒ Stripping corners provide stripping clearance of approx. 40 mm.
- ⇒ The permissible concrete pressure is 80 kN/m².
- ⇒ The corner is attached to the formwork with the NOE Toplock or by bolting with M18x160 bolts.



Before using the formwork, read through the assembly and use manual and observe the safety advice given in each chapter at all times!

Everyone who works with the product must receive instruction from a suitably qualified member of the site supervisory staff.



A risk analysis covering all situations on site must be carried out by a responsible person. Components must be free of defects. Therefore visual inspection and/or testing of each component are essential at all stages of the work!

10.3.1 Erecting formwork with stripping corners

- ◆ When erecting formwork for a shaft or similar features, it is recommended that erection starts with the stripping corner at the corner.

When doing this, it is important to ensure that the stripping corner is in the "erection-ready state", i.e. the moving side parts have been fully folded out. This is done by pressing or pulling the crane lug with the side facing the rear face of the formwork upwards. The simplest way of doing this is by suspending the stripping corner from the crane, e.g. when moving it into the installation position.

Set the safety wedge to ensure the sides cannot be unintentionally folded together.

- ◆ Attach the NOEtop4 panels to one another to suit the plan arrangement then fasten and align them with Toplock V or M18 x 160 bolts. Extend the formwork if necessary.
Apply release agent to the front and back formwork faces in accordance with the formwork preparation instructions.
- ◆ Fix reinforcement. Attach the outside face formwork coated with release agent and install ties (seal any surplus tie rod holes with sealing pins).

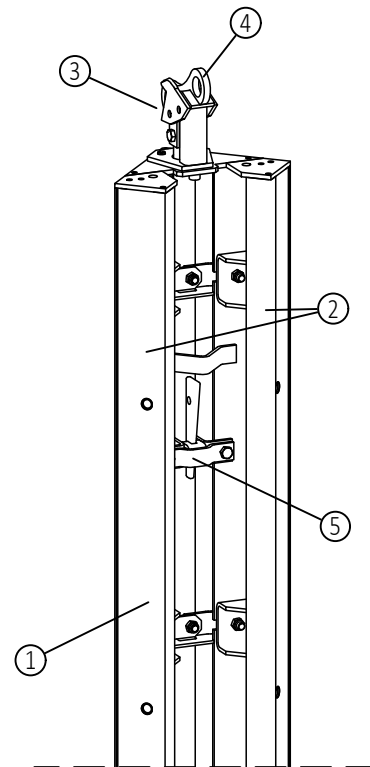

- 1 NOEtop4 stripping corner
- 2 Moving side parts
- 3 Lever head
- 4 Crane lug
- 5 Safety wedge



Taping the joints between the fixed core and the moving side parts of the stripping corner with self-adhesive tape is recommended to reduce the build up of dirt and the need for cleaning. It also results in a clean, flat concrete surface.

10.3.2 Concreting

- ◆ Before concreting, check that the shoes are fully moved out and the safety wedge has been struck home.
- ◆ Check the construction of the NOEtop4 formwork in accordance with the NOEtop4 assembly and use instructions.
- ◆ Do not exceed the permissible pressure during concreting (DIN 18218 'Pressure of fresh concrete on vertical formwork'), i.e. pay attention to the rate of rise of the concrete.

For 1-sided ties	Ø20 mm	-	permissible concrete pressure 80 kN/m ²
For 2-sided ties	Ø20 mm	-	permissible concrete pressure 80 kN/m ²

- ◆ If using internal vibrators refer to DIN 4235 Part 2 "Compaction of concrete by internal vibrators".

10.3.3 Stripping the formwork

- ◆ First remove the anchors and strip the external formwork.

Before stripping check:

- Minimum stripping time!
- Concrete compressive strength!

- ◆ Remove the safety wedges from the stripping corners.
- ◆ Insert the lever into each of the crane lugs of the lever head in turn, press or pull in the direction of the back of the formwork and bring the stripping corners evenly and in incremental stages into the stripping setting.

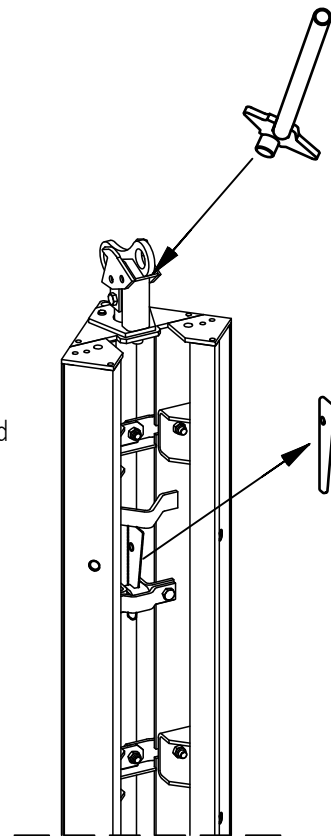
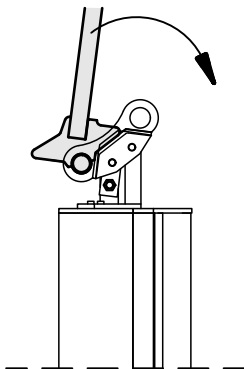

Shown without attached NOEtop4 panels.

Do not attach the formwork to the crane, do not lift it until the formwork has been completely released from the concrete and the stripping corners have been completely folded together.

DO NOT USE THE CRANE TO RELEASE THE FORMWORK FROM THE CONCRETE !

Check again that all the tie rods and anchors have been removed before lifting with the crane.

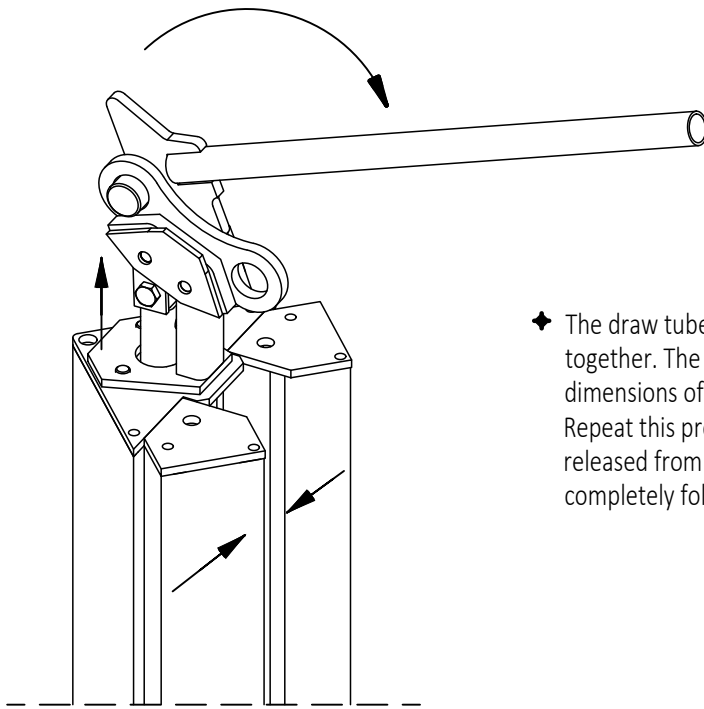

Shown without attached NOEtop4 panels.

- ◆ The draw tube is moved upwards and the moving side parts fold up together. The formwork releases from the concrete and the external dimensions of the internal core formwork shorten (approx. 40 mm). Repeat this procedure in steps until the formwork is completely released from the concrete and the stripping corners have each completely folded up together.

- ◆ After the formwork is completely released from the concrete, the 4 stripping corners can be attached to the crane's lifting tackle and the complete inner formwork unit moved in a single lift to the next point of use or for cleaning.

Attach the lifting tackle to the upper eye of the crane lug (the one that points towards the front face of the formwork), note that pulling the wrong eye will fold the stripping corners out again.

Ensure that there no loose objects, e.g. the lever, are on or in the formwork.

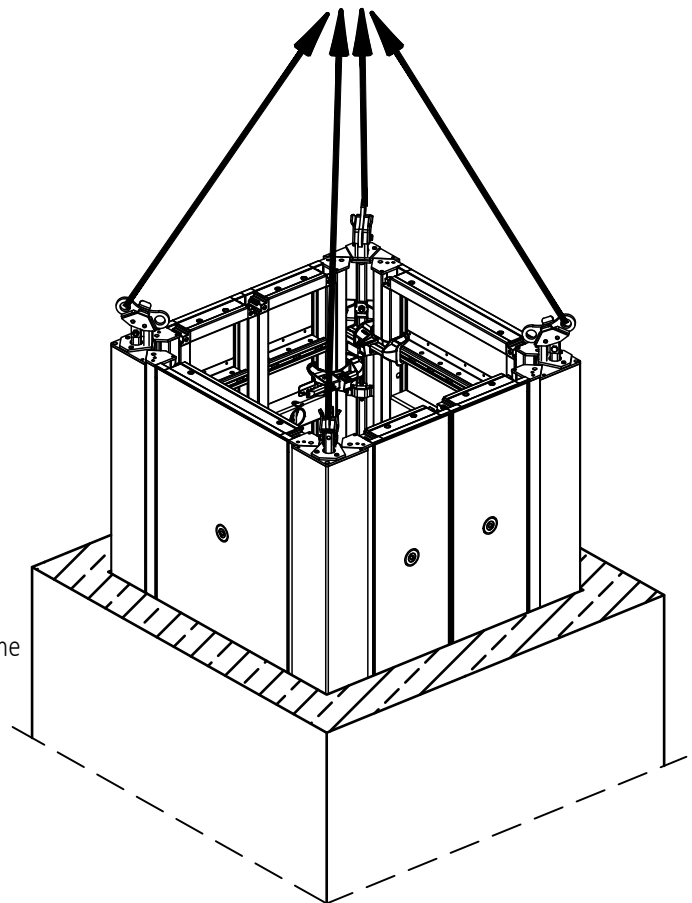



Permissible tensile force applied at the crane lug per stripping corner: 1000 kg
(Only 3 of the crane lugs can be assumed to be loadbearing at any one time!)

Do not exceed the load capacity of the crane.

10.3.4 Attaching to NOEtop4 formwork elements

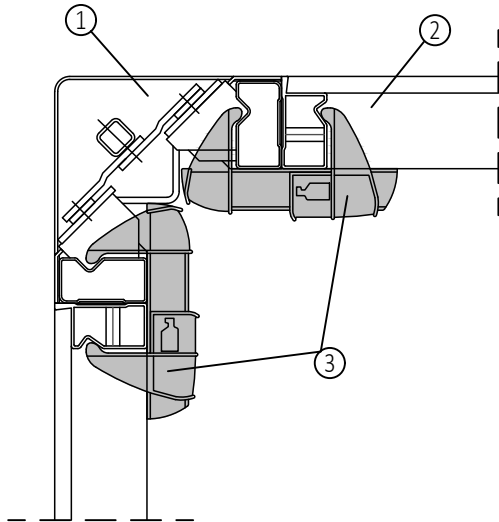

The stripping corner is clamped to the NOEtop4 frame panel with the NOE Toplock.

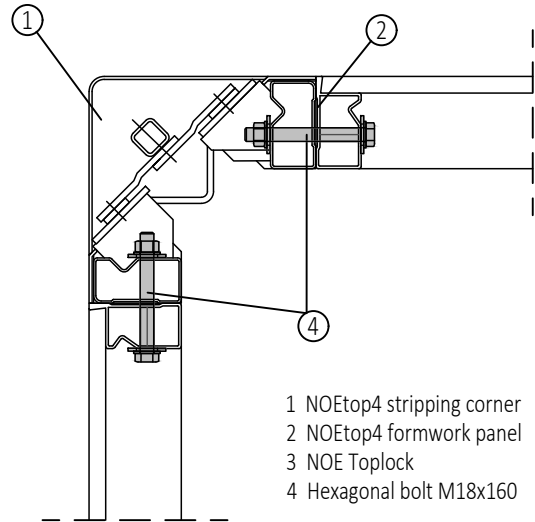

- 1 NOEtop4 stripping corner
- 2 NOEtop4 formwork panel
- 3 NOE Toplock
- 4 Hexagonal bolt M18x160

Alternatively the stripping corner can be bolted to the NOEtop4 frame panel. M18 x 160 bolts are used for this.

Numbers of Toplock V/X		
	Panel height [mm]	Number
	3600 mm	4
	3000 mm	4
	900 mm	1

Number of threaded connections		
	Panel height [mm]	Number
	3600 mm	4
	3000 mm	4
	900 mm	2

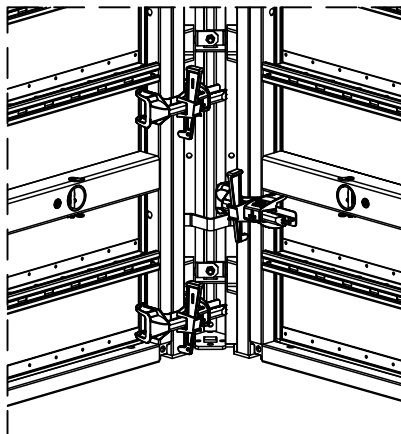

ATTENTION:
NOE Toplock must be attached at staggered heights!

10.3.5 Stripping and erection settings of the stripping corner

The stripping clearance of the stripping corner is approx. 20 mm.

◆ Cross-section
Stripping corner in erection setting

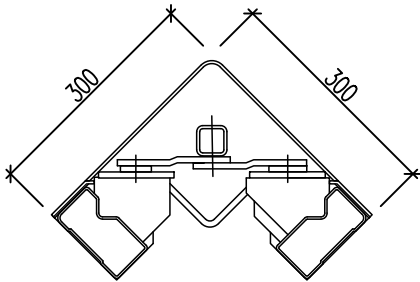

◆ Cross-section
Stripping corner in stripping setting

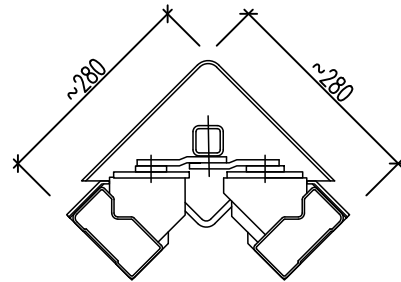

Example of formwork in erection setting

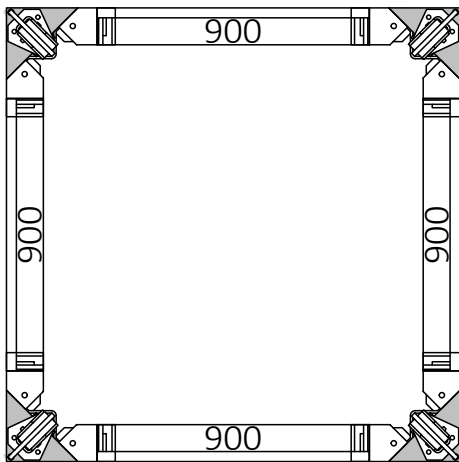

Example of formwork in stripping setting

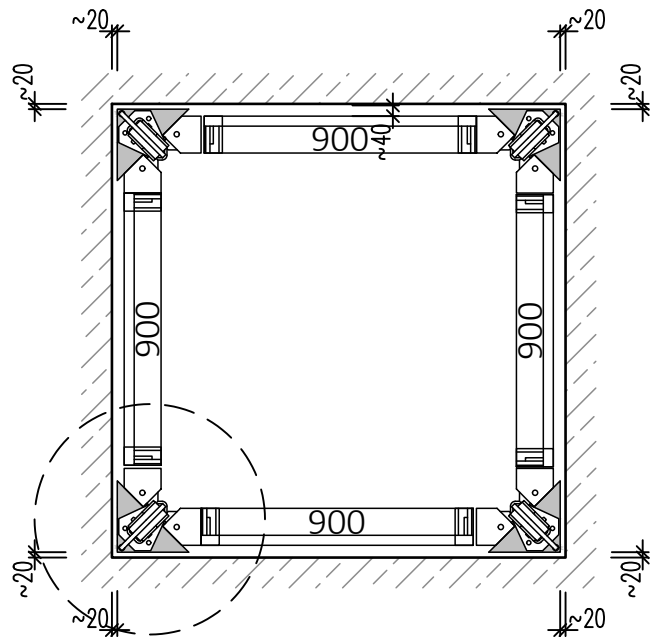

◆ Detail
Stripping clearance

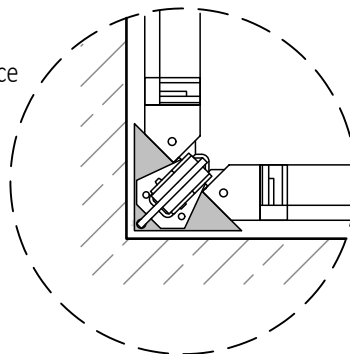

10.3.6 Extending stripping corners

First erect the lower formwork elements in the specified plan shape as described above. Then the lever head must be removed to allow the stripping corners to be extended. The lever head is fitted with a bayonet connector and is secured with a bolt.

- ◆ First release and take out the bolt (it will be needed later to connect the draw tubes)

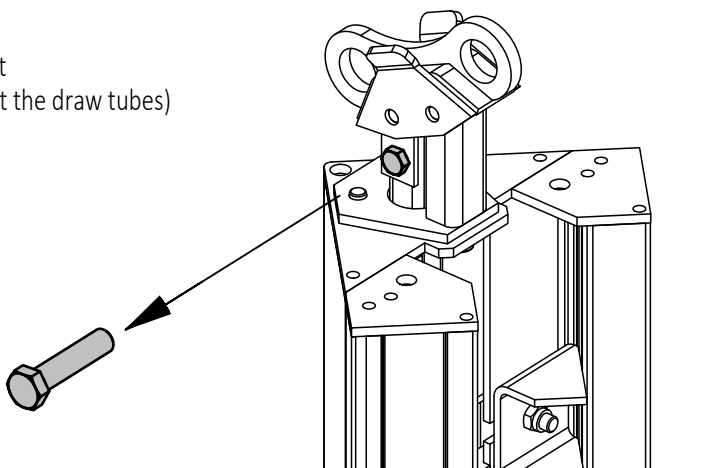

- ◆ Turn the head approximately 30° anticlockwise to release it. Then the locking pin heads can be guided out of the large holes in the plate and the head removed.

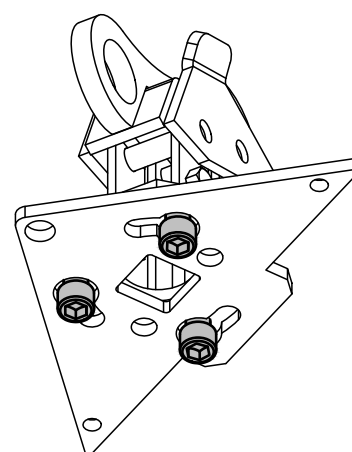
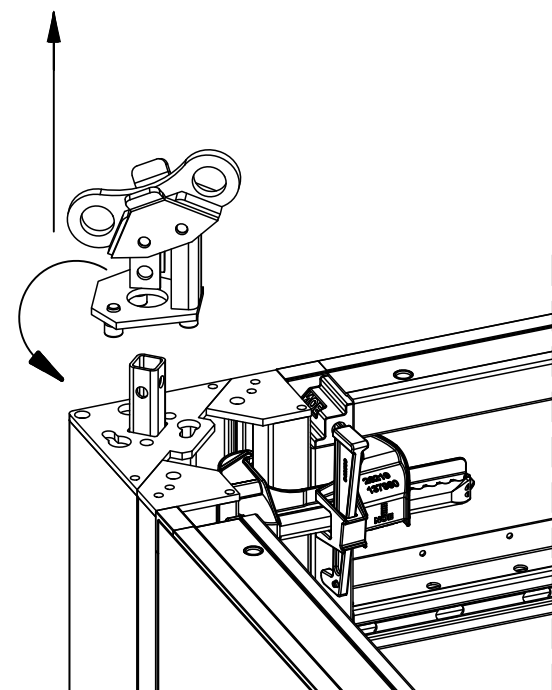

View from below:
Cover plate and lever head with bayonet lock ("bayonet lock")

- ◆ Installing the extension element. The draw tube on the lower stripping corner is threaded through rectangular opening in the base plate and then connected and secured with a bolt.

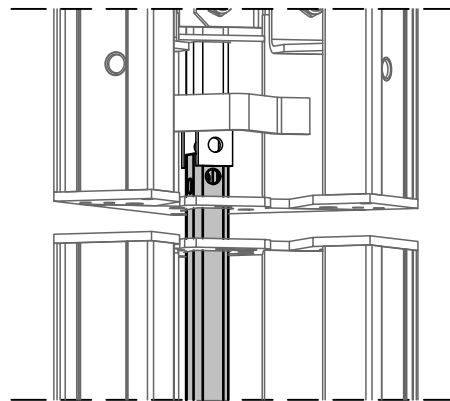
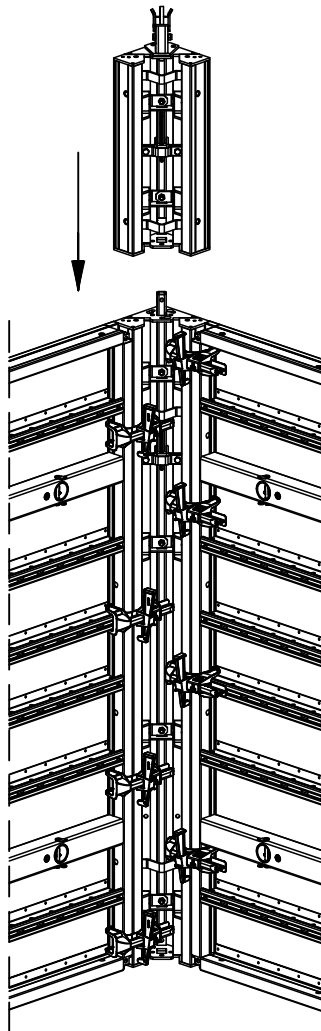

Detail 1:
Threading the draw tube

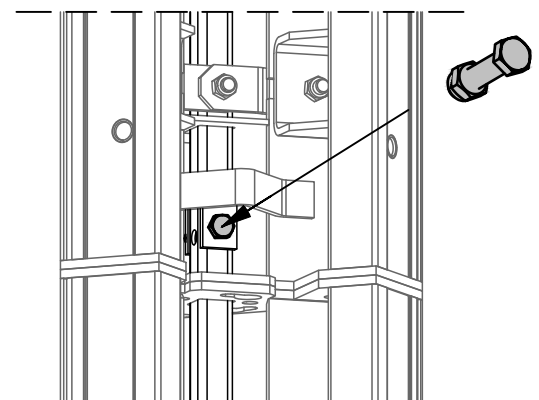

Detail 2:
M16x70 bolt
at the connection

- ◆ Connect the extension element of the NOEtop4 frame panel to the stripping corner and secure them together with NOE Toplock.



If the stripping corners are to be extended in advance of installation, e.g. formwork preassembled on its side, then the roughly butted base and cover plates of the corners must be bolted together with 2 M16x40 bolts ! The corners must be in the erection setting in order to be able to remove the lever head.

10.3.7 Crane transport

- ◆ The corner can be suspended from the 2 integrated crane bows for transporting the stripping corner horizontally, e.g. for loading or unloading.

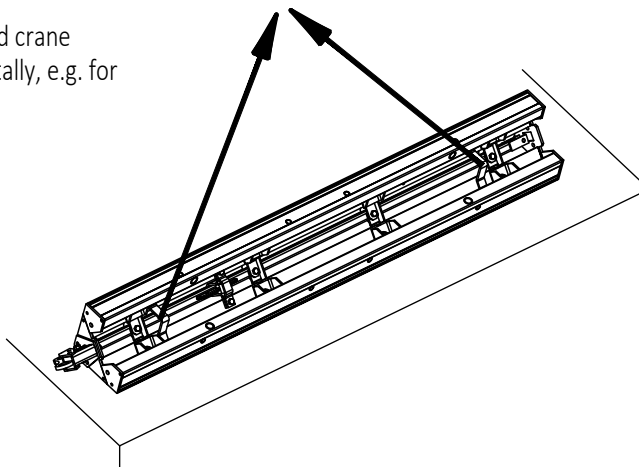

- ◆ The crane hooks can be engaged into the crane lugs of the lever head for transporting vertically. This also results in the stripping corners being brought into the erection setting simultaneously. They each still have to be secured with the wedge.

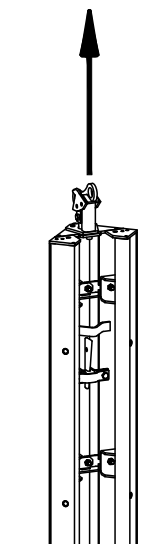

- ◆ After the formwork has been released from the concrete, the NOEtop4 stripping corners are suspended from the crane lugs and the complete formwork moved in a single lift.

Attention:

Suspend the formwork from the crane lugs pointing to the formwork lining side. Otherwise the formwork will be separated again.

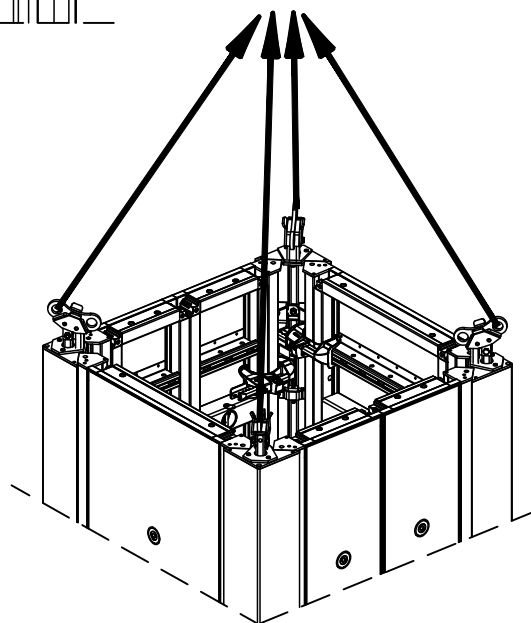

11. Use as foundation formwork

Pad foundation with side-on panels

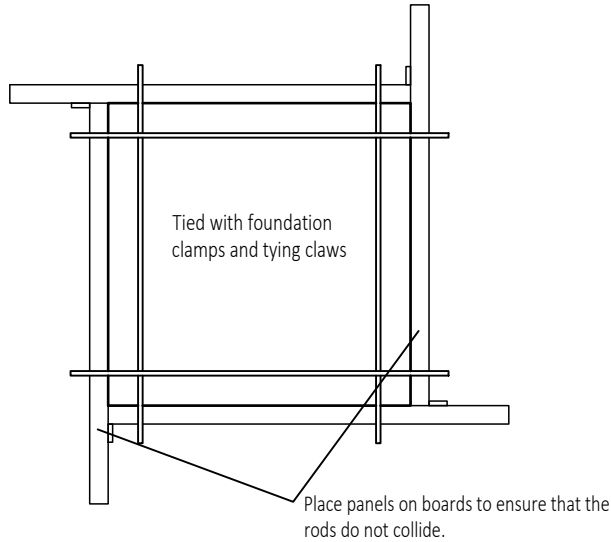

Detail of tie rod at top

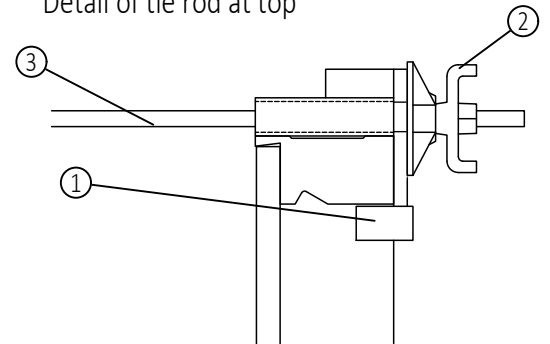

Tying can also be done using multi-claws.

Detail with tie at bottom Tie with foundation clamp

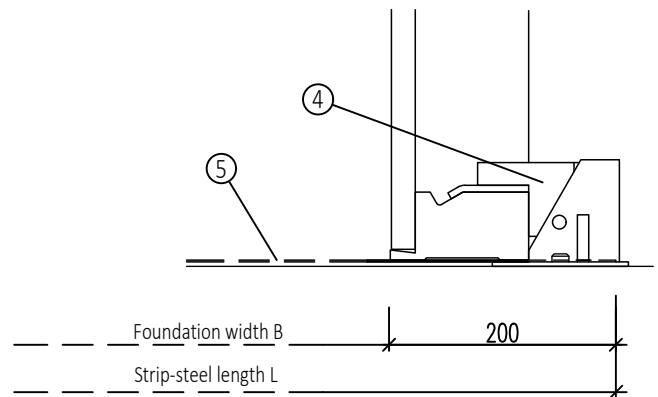

Example of panel corner connection Butt corner joint with Toplock X

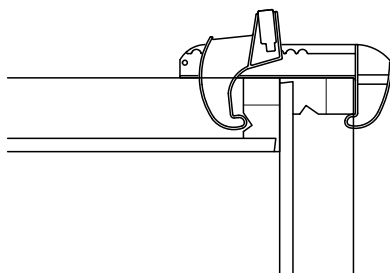

Attach 3 locks at height of 1200 mm.

Foundation formwork to be supported push pull safe on site

Strip foundations with side-on panels

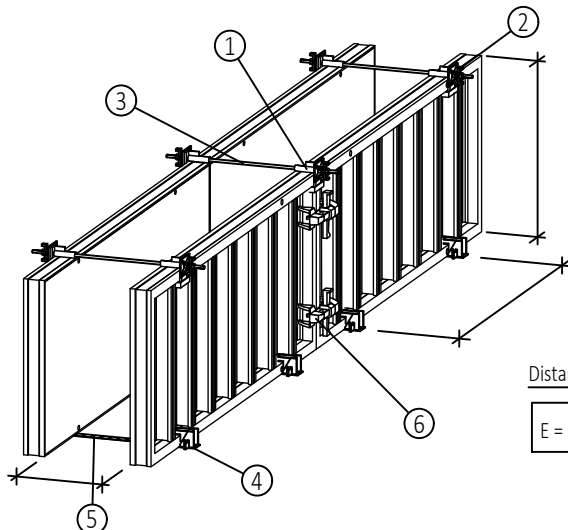

- 1 Tying claw, Part No. 137500
- 2 Wingnut w. plate, Part No. 691700
- 3 Tie rod $\varnothing 15$ mm, Part No. 67.....
- 4 Foundation clamp, Part No. 137297
- 5 Strip-steel stressing device, Part No. 108031
- 6 NOE Toplock V / X

Length of strip-steel

$L = B + 400 \text{ [mm]}$

Distance between foundation clamps

$E = 36 / (25 \times H^2) \text{ [m]}$

Permissible tension force 12 kN.
Cut to length at a hole centre!

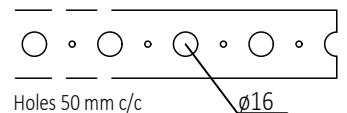

for H = 0.8 m E = 2.25 m
for H = 1.0 m E = 1.45 m
for H = 1.3 m E = 0.85 m
Min. 2 clamps per panel.

12. Crane transport, working scaffolds and stabilizers

12.1 Using cranes to transport panels

12.1.1 Crane transport general advice

When using crane hooks, lifting pins and transport hangers:

- Observe the relevant operating instructions!
- Check the condition of the transport equipment before each use!
- Check that the load is correctly seated and the transport equipment is secured before each lift!

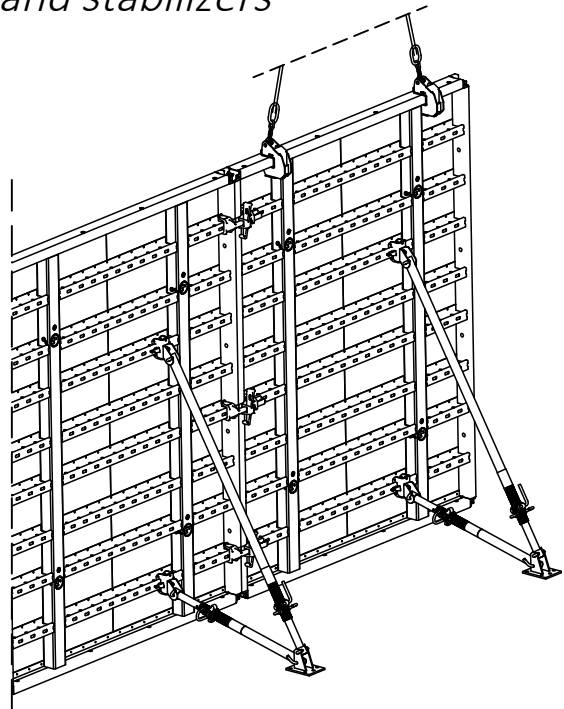

Moving panels:

(refer to Assembly instructions 3.2.2)

1. Attach the crane hook to the formwork and lightly tension the crane rope.
2. Remove connections to other formwork elements and release the stabilizers from the ground.
3. Lift the formwork with the crane.
4. Do not release the crane hook until after the formwork has been set down and secured against overturning

(see 1.2).



Observe the lifting equipment regulations during transport operations using the crane, erecting panels and installing of working places!

12.1.2 Transporting several panels in a stack using 4x transport hangers

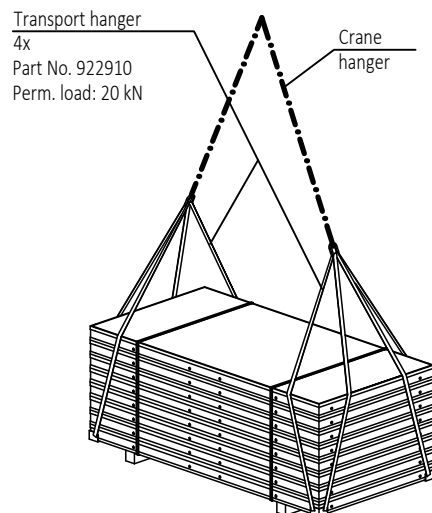

Transporting panel stacks is only allowed using 4x transport hangers.
Permissible stack weight: 2000 kg!

Requirements for use:

- Form the stack with elements of the same width that fit neatly over one another.
- The upper layers may contain combinations of smaller width panels if no gaps occur between the elements and each element is held in place by at least 2 round slings.
- The bottom layer in the stack must always be composed of one element.
- Stack height max. 1.25 m, i.e. 10 NOEtop panels, assuming that the load capacity is not exceeded.
- Use a 2 strap hanger, for element widths in excess of 2.0 m use a 4-strap hanger.

Unsuitable stack

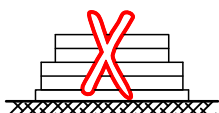

Suitable stack

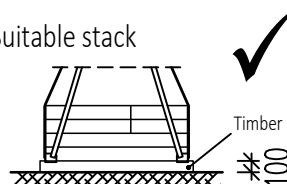

12.1.3 Transporting individual panels horizontally by crane using lifting pins

Correct

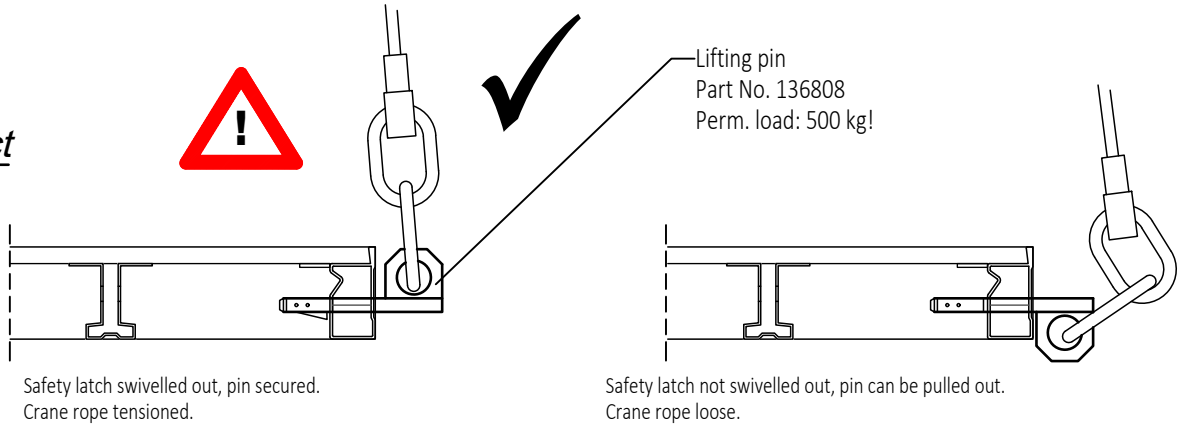

Incorrect

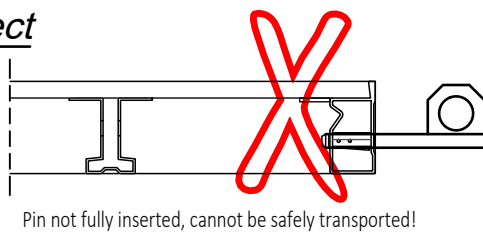

Operating instructions of the lifting pin must be observed!

12.1.4 Transporting panels vertically by crane with crane hook

Panel with finished side upwards

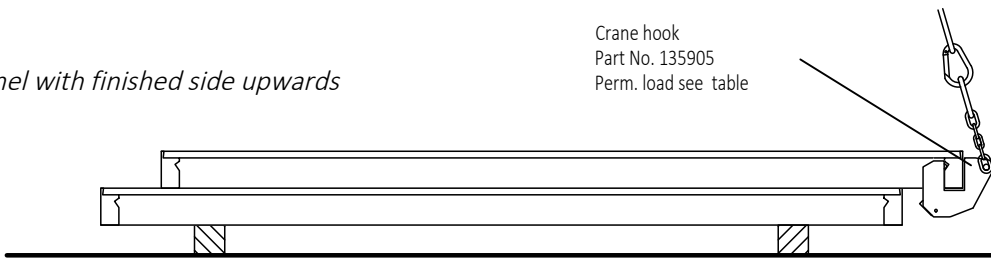

Panel vertical

Panel with finished side downwards

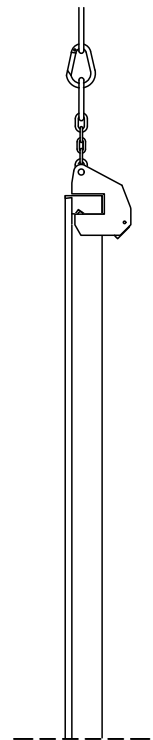
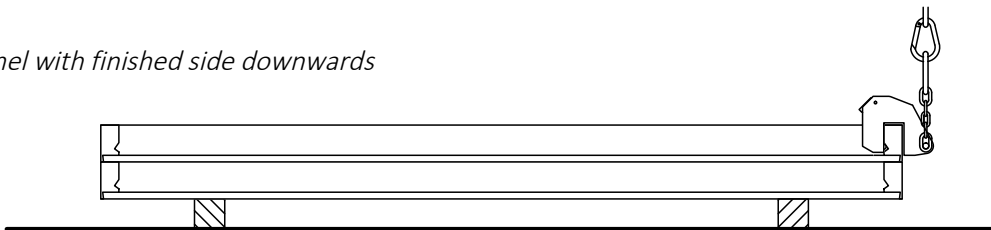

Perm. load in relation to load direction

Vert. pull 90°	Incl. pull 60°	Incl. pull 45°
Perm. T [kg]	Perm. T [kg]	Perm. T [kg]
2000	1500	1200

12.1.5 Attaching the crane hook



Observe the requirements of the crane hook operating instructions.

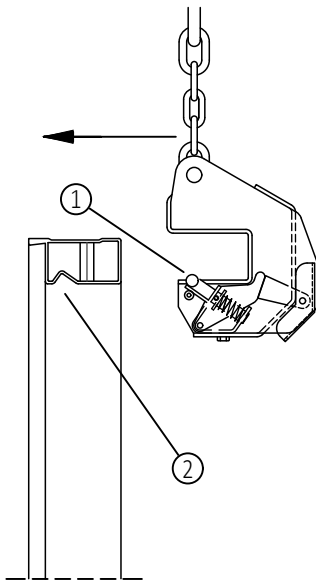

Push the crane hook with some force over the edge profile of the panel until it meets the stop. The safety pin is pushed downwards and inwards by this action and springs up and out again automatically in the area of the nib and secures the crane hook.

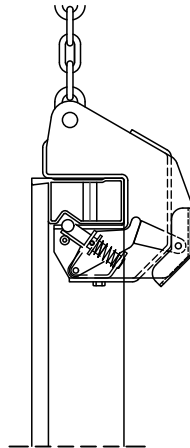

- 1 Safety pin
- 2 Nib
- 3 Release lever

12.1.6 Detaching the crane hook

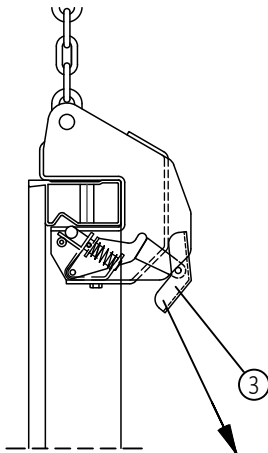

Pull the release lever downwards at the angle shown by the arrow. The safety pin is pressed in and the crane hook can now be released from the panel.

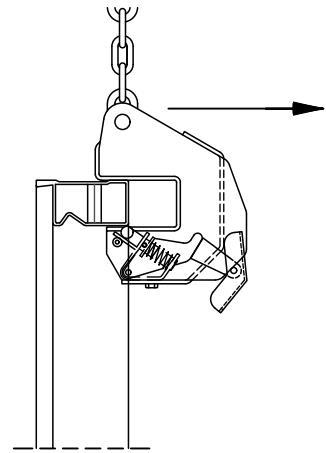

To release the crane hook whilst standing on the ground, insert a bent piece of wire into the hole in the release lever and pull it.

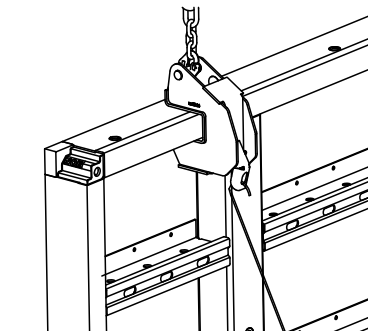

12.1.7 Transporting small items with NOE box

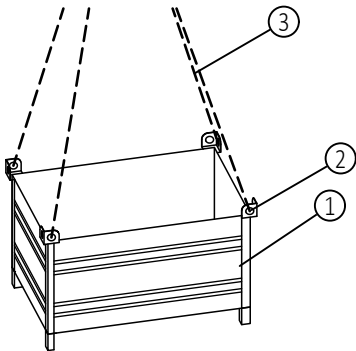

- 1 NOE Box Part No. 697598
- 2 Eyes for attaching to crane hooks
- 3 Sling ropes from crane

NOE boxes are intended for the safe transport of small items (element connections, tie rod accessories etc.).
Alternatively you can use robust bags.

Transport small items in secure bundles e.g. in NOE boxes.
Max. total weight per box: 20 kN (2000 kg)!

Long accessories such as bundles of bracing or platform brackets must be secured with steel bands or be loaded and unloaded safely by other methods e.g. on pallets for slab props (see 15.1.8).

12.1.8 Transporting stabilizers and the like with NOE pallets

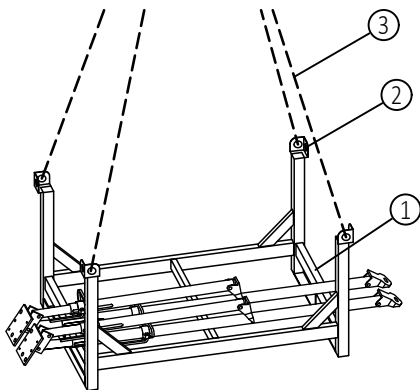

- 1 NOE pallet Part No. 697599
- 2 Eyes for attaching to crane hooks
- 3 Sling ropes from crane

In order to transport, load and unload long accessories safely (stabilizers, bracing, etc.) they should be stacked on NOE pallets or bundled.

Bundle long accessories for safe transport e.g. in NOE pallets.
Max. load per pallet: 16.5 kN (1650 kg)!

12.1.9 Transporting parts with NOEcase

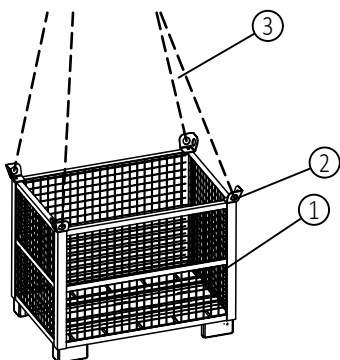

- 1 NOEcase, Part No. 697591
- 2 Eyes for attaching to crane hook
- 3 Sling ropes from crane

Max. load: 1000 kg!

12.2 Transport restraint and storage of formwork panels

12.2.1 Storage with NOErack - panel rack

For safe, space-saving and facing-protective storage on site. Assemble the NOErack - panel rack after delivery to site and insert the NOEtop4 - panel elements.

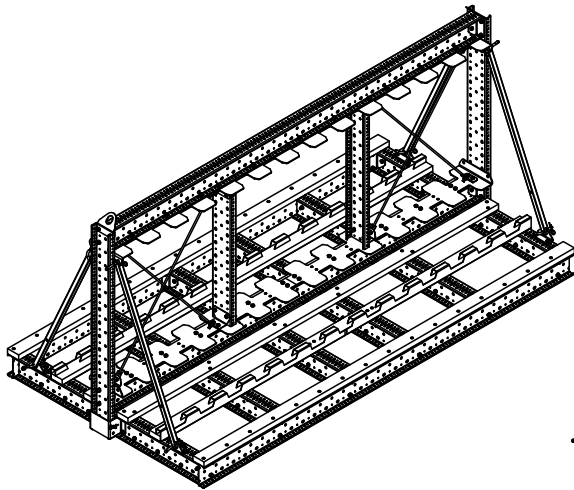

Observe the operating instructions for the NOErack!

- ⇒ For use with NOEtop and NOEtop4 panels with a profile height of 122 mm
- ⇒ Maximum panel height: 3900 mm
- ⇒ Maximum panel width: 2400 mm

- ◆ Place the NOErack down on a flat substrate in a stable position.
- ◆ Assemble the NOErack after delivery and secure against movement
- ⇒ Refer to the NOErack operating instructions for a step-by-step explanation.
- ◆ Place the NOEtop4 - formwork panels into the slots provided in the toothed profiles.

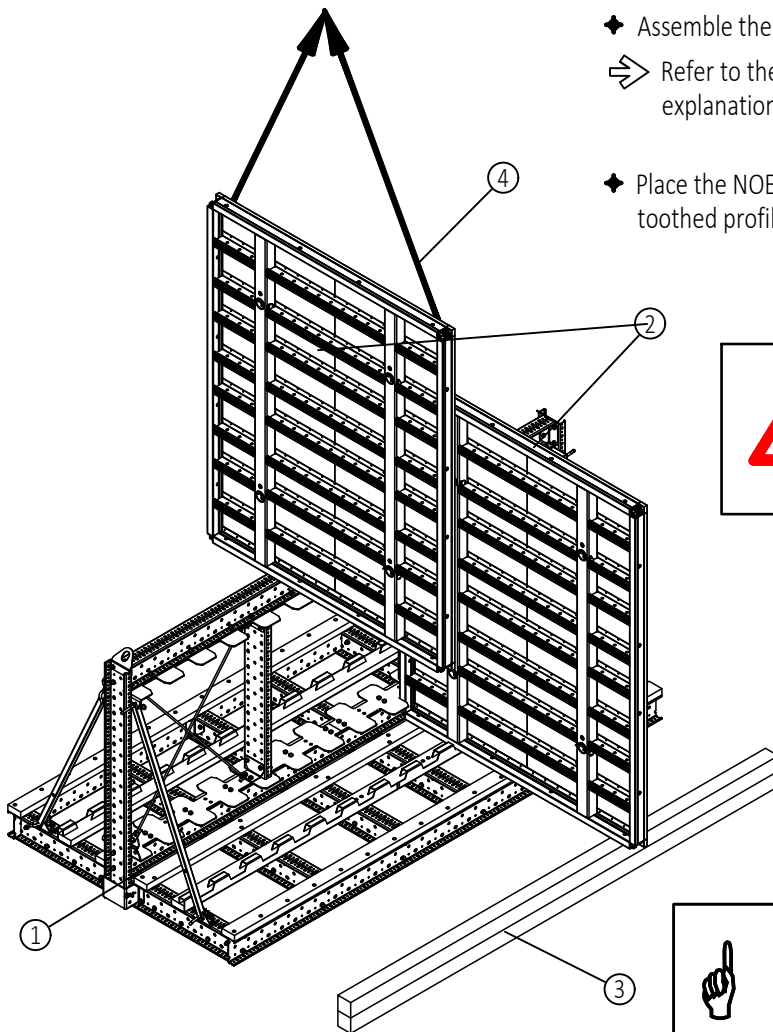

Always work evenly from the middle outwards when loading the NOErack with panels. Do not place single panels in isolation on the end of the rack!

- 1 NOErack, Part No. 697600
- 2 NOEtop4 - formwork panel
- 3 Supports
- 4 Transport hangers



Suitable additional support must be provided for panels that project more than 80 cm beyond the edge of the NOErack (e.g. timber beams).

12.3 NOEtop walkway brackets

Working scaffold in acc. with DIN EN 12811-1
 Scaffold class 2 - max. 150 kg/m² uniformly distributed
 Max. effective width 1.90 m per bracket

If walkway brackets are to be used, the formwork must be structurally stable, e.g. stabilizers attached to this side of the panels.

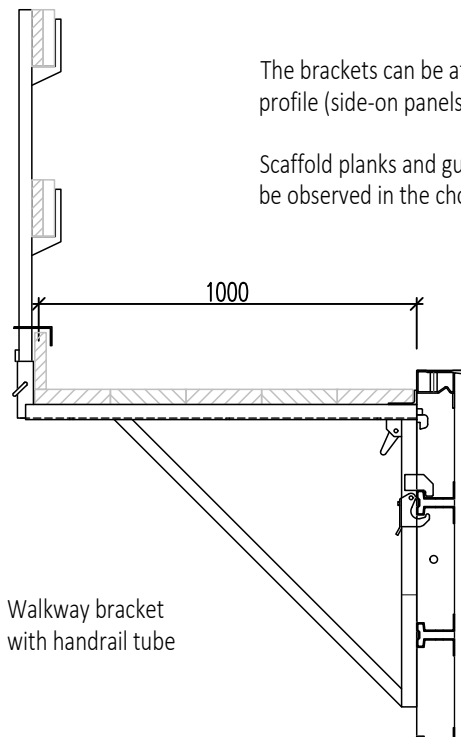

The brackets can be attached to the hat profile (end-on panels) or the elongated holes of the hat profile (side-on panels) (see assembly instructions).

Scaffold planks and guardrail boards provided on site. The regulations for working scaffolds must be observed in the choice of scaffolding boards and guard rail boards !



Max. bracket spacing: 1.90 m

Board/plank thickness in mm
 (scaffold group 2)

Board/plank width	Span in m		
	1,50	1,75	1,90
20 cm	35	40	45
24 and 28 cm	35	35	40

12.3.1 Assembly instructions for walkway brackets with railings and planking

- ◆ Check the following before the walkway brackets are attached:
 - The supporting formwork construction must be structurally stable.
 - The spacing of the brackets complies with DIN EN 12811-1 Working scaffolds
 - ⇒ max. 1.90 m effective width per bracket
 - Position of the walkway brackets
 - ... In the upper hat profile
 - ⇒ Fit front scaffold board only after erection of the formwork to allow the crane hook to be attached
 - ... To provide safety against falling at heights > 2.00 m
 - ⇒ attach walkway brackets correspondingly lower
 - Attach the working platform with trapdoor as the first element!

- ◆ Press and keep pressed the release, which opens the release lever (bottom) and securing slots (top) and allows the walkway bracket to be attached.

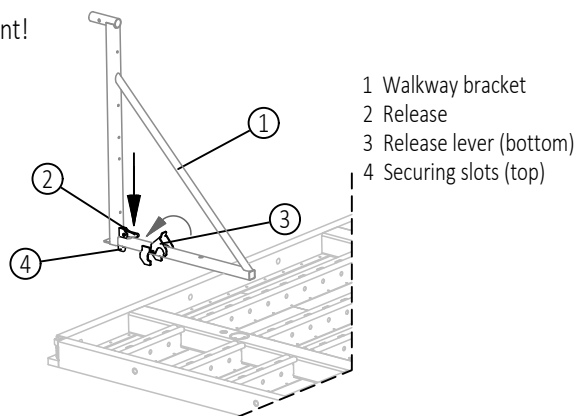

NOEtop4 Formwork



◆ On to a horizontal hat profile:

Introduce the bottom hook of the bracket into the groove on the hat profile. Let go of the release and the release lever (bottom) closes automatically. The brackets may be attached in any position on the hat profile.

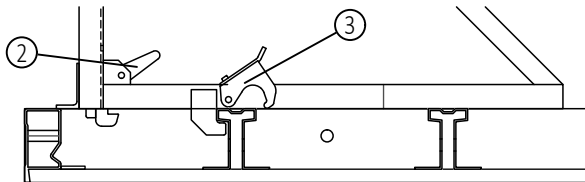

◆ On to a vertical hat profile:

The top hook of the bracket is introduced into the elongated hole in the hat profile. Let go of the release and the securing slide (top) moves forward and wedges the hook into the elongated hole.

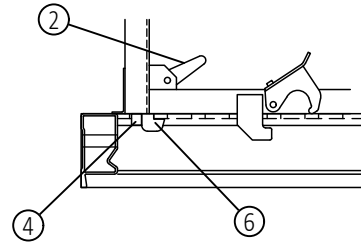

◆ Insert the handrail tube into the bracket and secure with plug

- 1 Walkway bracket
- 2 Release
- 3 Release lever (bottom)
- 4 Securing slide (top)
- 5 Bottom hook
- 6 Top hook
- 7 Handrail tube
- 8 Plug

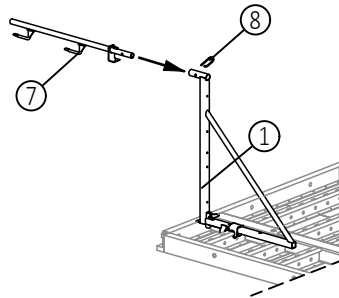

 Check once more that the brackets are securely seated!

◆ Attaching planking and railings

 Attach the crane hook in the edge profile:
If the walkway bracket is attached to the top of the panel, the front scaffold board can only be installed after the panel is structurally stable and the crane hook has been detached.

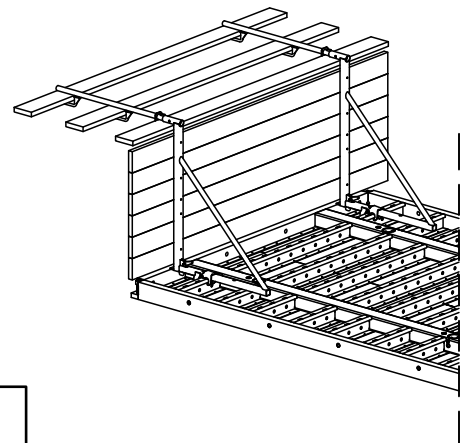

Attach guardrail boards and toeboard

 Before each first use must be checked that the scaffold is attached correctly to the edge profile and that the safety catch is locked (see 15.3).

◆ Dismantling the walkway bracket

To dismantle, lay the formwork elements with complete scaffolding unit down and take off the individual components from that position. This is carried out in the reverse order to the assembly.

12.4 NOEtop fall protection

From a formwork height of 2.00 m there must be fall protection measures on both sides, i.e.

- a) the second side also has a walkway bracket attached or
- b) a railing is attached to the second face formwork.

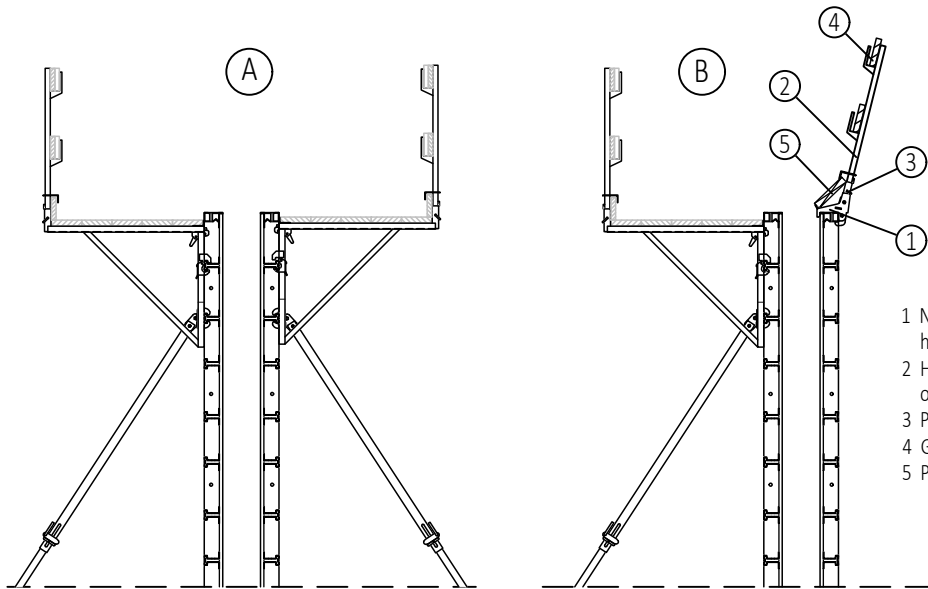

Clamp the clamp support to the edge profile by driving in the wedge. Insert the handrail tube into the bracket and secure with plug. Place guard rail boards and platform board in position.

- 1 NOEtop clamp support for handrail tube, Part No. 552214
- 2 Handrail tube, Part No. 111400 or Part No. 111403
- 3 Plug, Part No. 890834
- 4 Guard rail board
- 5 Platform board

12.5 Stabilizers up to 5000 mm

Prop push-pull 2770-5000 mm

Part No. 697028 Weight 25,7 kg
perm. load capacity 29,7 - 6,8 kN

Prop push-pull 2100 - 3650 mm

Part No. 697027 Weight 19.1 kg
perm load capacity 29.7 - 12.8 kN

Prop push-pull 1000-1510 mm

Part No. 697026 Weight 9.4 kg
perm. load capacity 29.7 kN

The props can be attached with the stabilizer adapter or with the hinge end joint and hammer-head bolt.

- 1 Prop push-pull top
- 2 Prop push-pull bottom
- 3 Bottom support, Part No. 697014
- 4 L-pin D16, Part No. 697010
- 5 Spring pin, Part No. 913304
- 6 Stabilizer connector, Part No. 697032
- 7 End swivel joint, Part No. 697012
- 8 Hammer-head bolt with handle, Part No. 319338
- 9 Uplift safety device

The supporting plates, connections, pins and spring pins are not included in the scope of supply of the props.

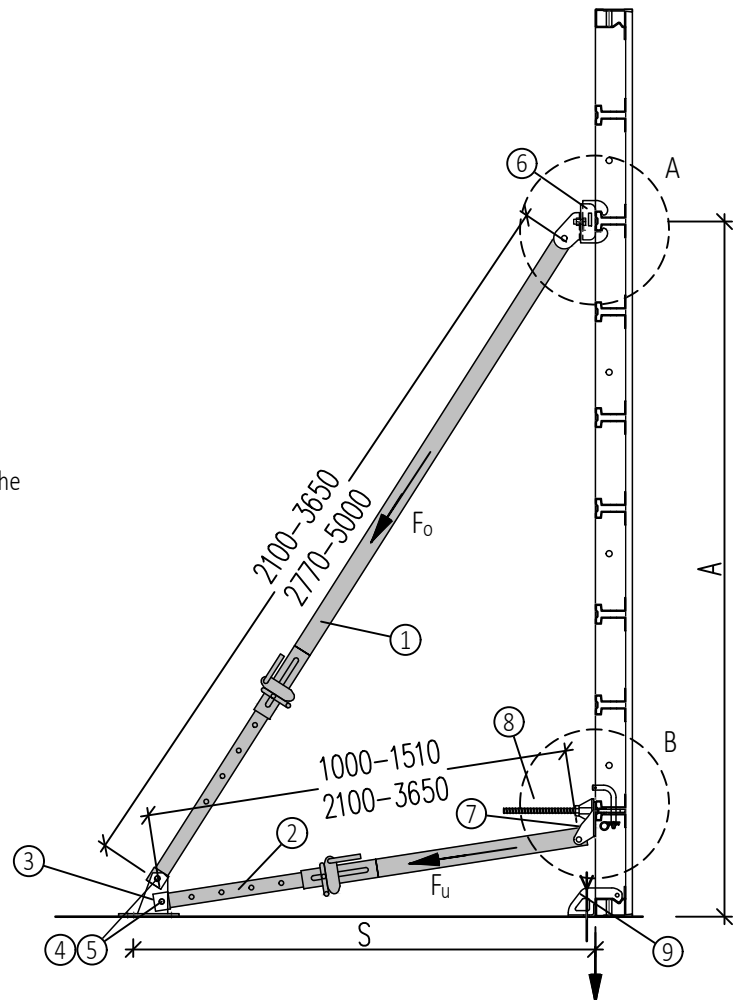

Detail A

Attaching with stabilizer adapter

Attaching to cross-profile on end-on and side-on panels.
 The stabilizer connector can be simply suspended on the horizontal profile and fixed with the wedge.
 In the case of attachment with a stabilizer connector, the maximum force transmitted into the hat profile must be limited to 15 kN.

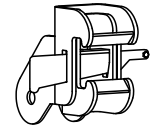
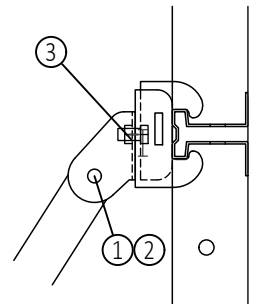

Detail B

Heavy duty attachment with tie rod with fixing lug

Attaching in the elongated hole of the hat profile by a tie rod with fixing lug and tie rod - sprint nut + L-pin and spring pin for end-on and side-on panels.
 In the case of attachment with a tie rod with fixing lug, the maximum force transmitted into the hat profile must be limited to 20 kN.

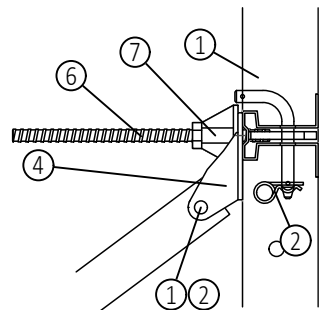

Detail C

Attaching with hammer-head bolt

Attached to the elongated hole of the hat profile by hammer-head bolt with handle and integral sprint for end-on and side-on panels.
 When the fastening with the hammerhead bolt is below approx. 60° no more than a max. 8 kN may be transferred into the hat profile.

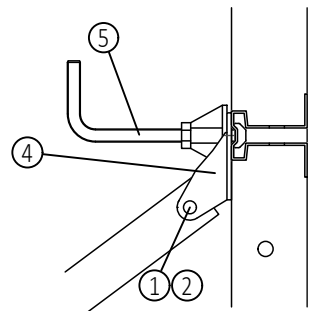

- 1 L-pin D16, Part No. 697010
- 2 Spring pin, Part No. 913304
- 3 Stabilizer connector, Part No. 697032
- 4 End swivel joint, Part No. 697012
- 5 Hammer-head bolt with handle, Part No. 319338
- 6 Tie rod with fixing lug, Part No. 850014
- 7 Tie rod - Sprint nut, Part No. 680580



Schematic diagram

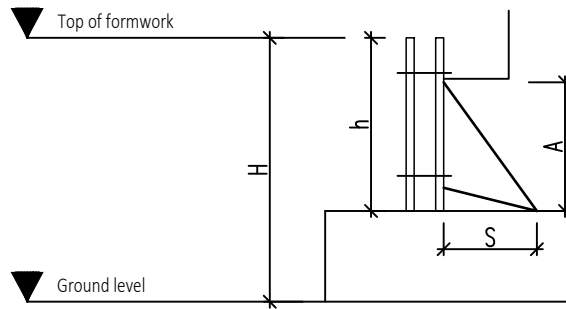

Plan

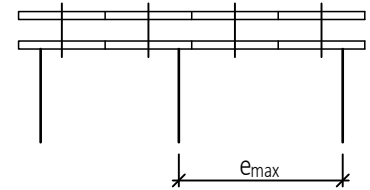

Table for effective widths and loads for attachment by stabilizer adapter

Panel height h [m]	Part number of top strut	Propping height A [m]	Distance S [m]	Height H above ground up to 7 m				Height H above ground up to 25 m			
				e _{max} [m]	Loads at e _{max}		F _A [kN/m]	e _{max} [m]	Loads at e _{max}		F _A [kN/m]
					F _O [kN]	F _U [kN]			F _O [kN]	F _U [kN]	
3,00	697027	2,00	1,18	2,40	6,2	1,4	1,9	2,40	9,9	2,3	5,4
3,60	697027	2,65	1,55	2,40	6,8	2,1	1,8	2,40	10,8	3,3	5,5
3,90	697028	2,90	2,30	2,40	6,0	2,2	0,0	2,40	9,5	3,5	3,0
4,50	697028	3,55	2,30	2,40	7,5	2,8	0,9	2,30	11,4	4,3	4,7
4,80	697028	3,55	2,30	2,40	8,6	2,6	1,4	2,00	11,4	3,5	4,9
5,40	697133	4,15	3,25	2,40	8,2	3,1	0,0	2,40	13,1	5,0	3,9
6,00	697133	4,35	3,25	2,40	10,1	3,1	0,7	2,25	15,0	4,6	5,3
6,60	697133	5,25	3,05	2,40	12,0	4,0	2,5	1,90	15,1	5,0	6,9
7,20	697133	5,55	3,20	2,40	13,7	4,1	3,1	1,65	14,9	4,5	7,1

Table for effective widths and loads for attachment by hinge end joint and hammer-head bolt

Panel height h [m]	Part number of top strut	Propping height A [m]	Distance S [m]	Height H above ground up to 7 m				Height H above ground up to 25 m			
				e _{max} [m]	Loads at e _{max}		F _A [kN/m]	e _{max} [m]	Loads at e _{max}		F _A [kN/m]
					F _O [kN]	F _U [kN]			F _O [kN]	F _U [kN]	
3,00	697027	2,00	1,18	2,40	6,2	1,4	1,9	1,9	7,9	1,8	4,2
3,60	697027	2,65	1,55	2,40	6,8	2,1	1,7	1,75	7,9	2,4	4,0
3,90	697028	2,90	2,30	2,40	6,0	2,2	0,0	2,00	7,9	3,0	2,5
4,50	697028	3,55	2,30	2,40	7,5	2,8	0,9	1,60	7,9	3,0	3,2
4,80	697028	3,55	2,30	2,20	7,9	2,4	1,3	1,40	8,0	2,5	3,5
5,40	697133	4,15	3,25	2,30	7,9	3,0	0,0	1,45	7,9	3,0	2,4
6,00	697133	4,35	3,25	1,90	8,0	2,4	0,6	1,20	8,0	2,5	2,8
6,60	697133	5,25	3,05	1,60	8,0	2,7	1,6	1,00	7,9	2,7	3,7
7,20	697133	5,55	3,20	1,40	8,0	2,4	1,8	0,85	7,7	2,3	3,7

The values in the table apply for wind loads in acc. with DIN 1055-4:2005-3, inland, wind zone 2, intermediate zone (Zone B), l/h=5
 Pressure coefficient 1.8
 Solidity 1.0
 Reduction factor 0.6 (service life up to 12 months)

Propping height bottom strut: 0,35 m
 Angle of stabilizer: approx. 60°
 Maximum effective width per stabilizer: e_{max} !!

In the edge area of the formwork (Zone A, free formwork end or beginning) the maximum effective width of the stabilizers must be halved.

For the calculation of the anchored load F_A the formwork weight of the NOEtop formwork was taken as 80 kg/m². In addition the listed values contain the partial safety factor 1.5 for the overall stability (DIN 1055-100).

All the given values are characteristic values.

Assembly

a) Individual parts for stabilizers up to approx. 4.00 m panel height

No.	Description
1	Prop push-pull 2100-3650 mm Part No. 697027 (1)
1	Prop push-pull 1000-1510 mm Part No. 697026 (2)
1	Base plate for push-pull brace Part No. 697014 (3)
4	L-pin D16 Part No. 697010 (4)
4	Spring pin Part No. 913304 (5)
2	Stabilizer connector Part No. 697032 (6)
_____ alternative _____	
2	End swivel joint Part No. 697012 (7)
2	Hammer-head bolt with handle Part No. 319338 (8)

Plan bottom support

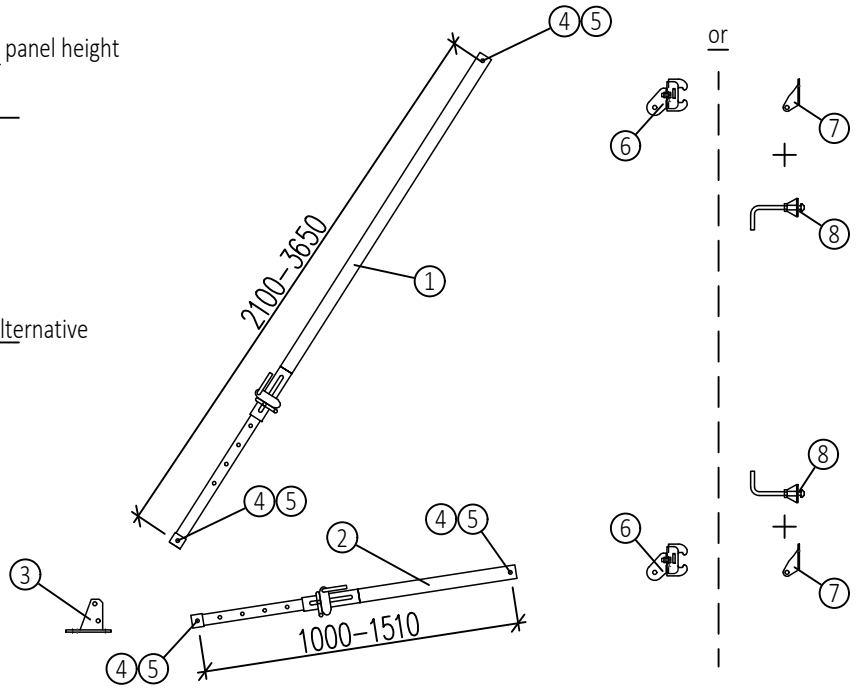
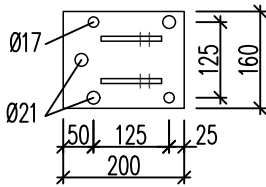

b) Individual parts for stabilizers up to approx. 5.30 m panel height

No.	Description
1	Prop push-pull 2800-5000 mm Part No. 697028 (1)
1	Prop push-pull 2100-3650 mm Part No. 697027 (2)
1	Base plate for push-pull brace Part No. 697014 (3)
4	L-pin D16 Part No. 697010 (4)
4	Spring pin Part No. 913304 (5)
2	Stabilizer connector Part No. 697032 (6)
_____ alternative _____	
2	End swivel joint Part No. 697012 (7)
2	Hammer-head bolt with handle Part No. 319338 (8)

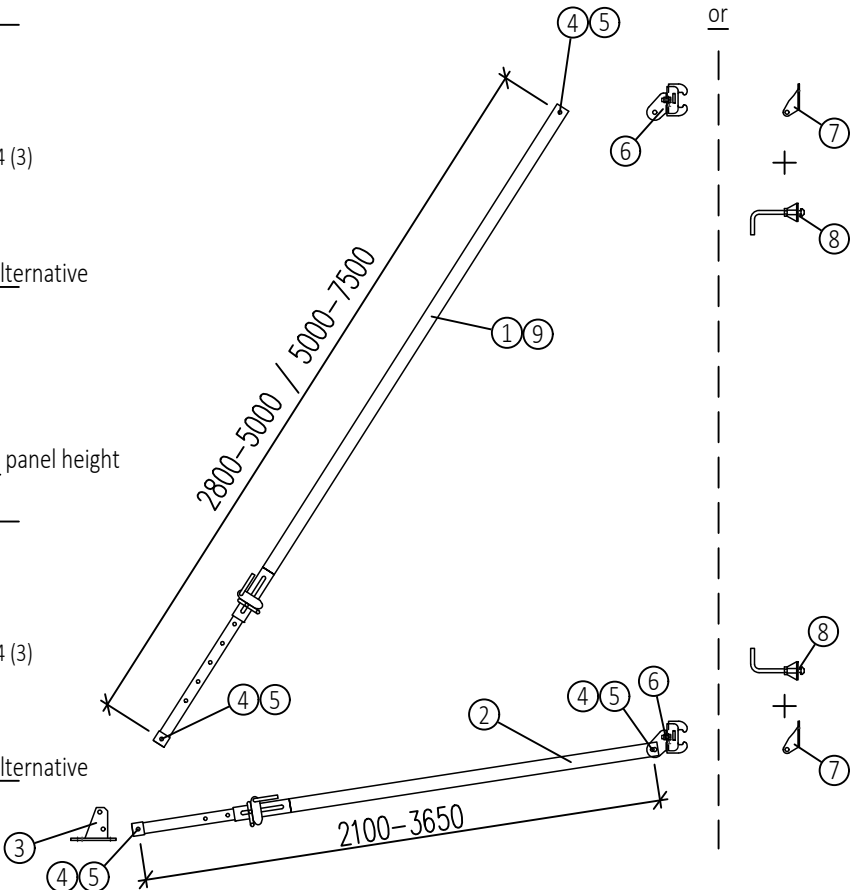

b) Individual parts for stabilizers up to approx. 6.62 m panel height

No.	Description
1	Prop push-pull 5000-7500 mm Part No. 697133 (9)
1	Prop push-pull 2100-3650 mm Part No. 697027 (2)
1	Base plate for push-pull brace Part No. 697014 (3)
4	L-pin D16 Part No. 697010 (4)
4	Spring pin Part No. 913304 (5)
2	Stabilizer connector Part No. 697032 (6)
_____ alternative _____	
2	End swivel joint Part No. 697012 (7)
2	Hammer-head bolt with handle Part No. 319338 (8)

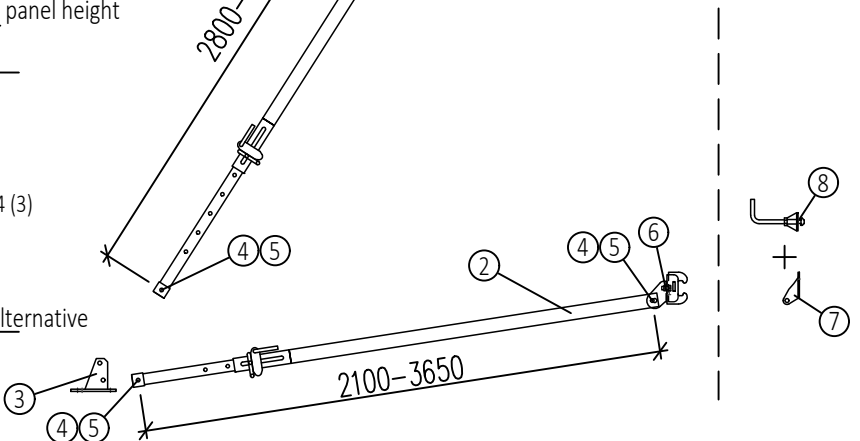

12.6 Stabilizers for high formwork

NOE stabilizer 6400 - 10300 mm

ATTENTION:
The strut and the anchors of supporting plate, as well as and the formwork construction are subject to structural analysis.

- 1 Stabilizer 6400-10300 mm
Part No. 697036
- 2 Base plate for push-pull brace Part No. 697014
- 3 L-pin D16 Part No. 697010
- 4 Spring pin Part No. 913304
- 5 Stabilizer connector Part No. 697032
- 6 End swivel joint Part No. 697012
- 7 Hammer-head bolt with handle Part No. 319338
- 8 NOEtop Fixation claw Part No. 136701

The props can be attached with the stabilizer adapter or with the hinge end joint and hammer-head bolt or tie rod with fixing lug.

Plan bottom support

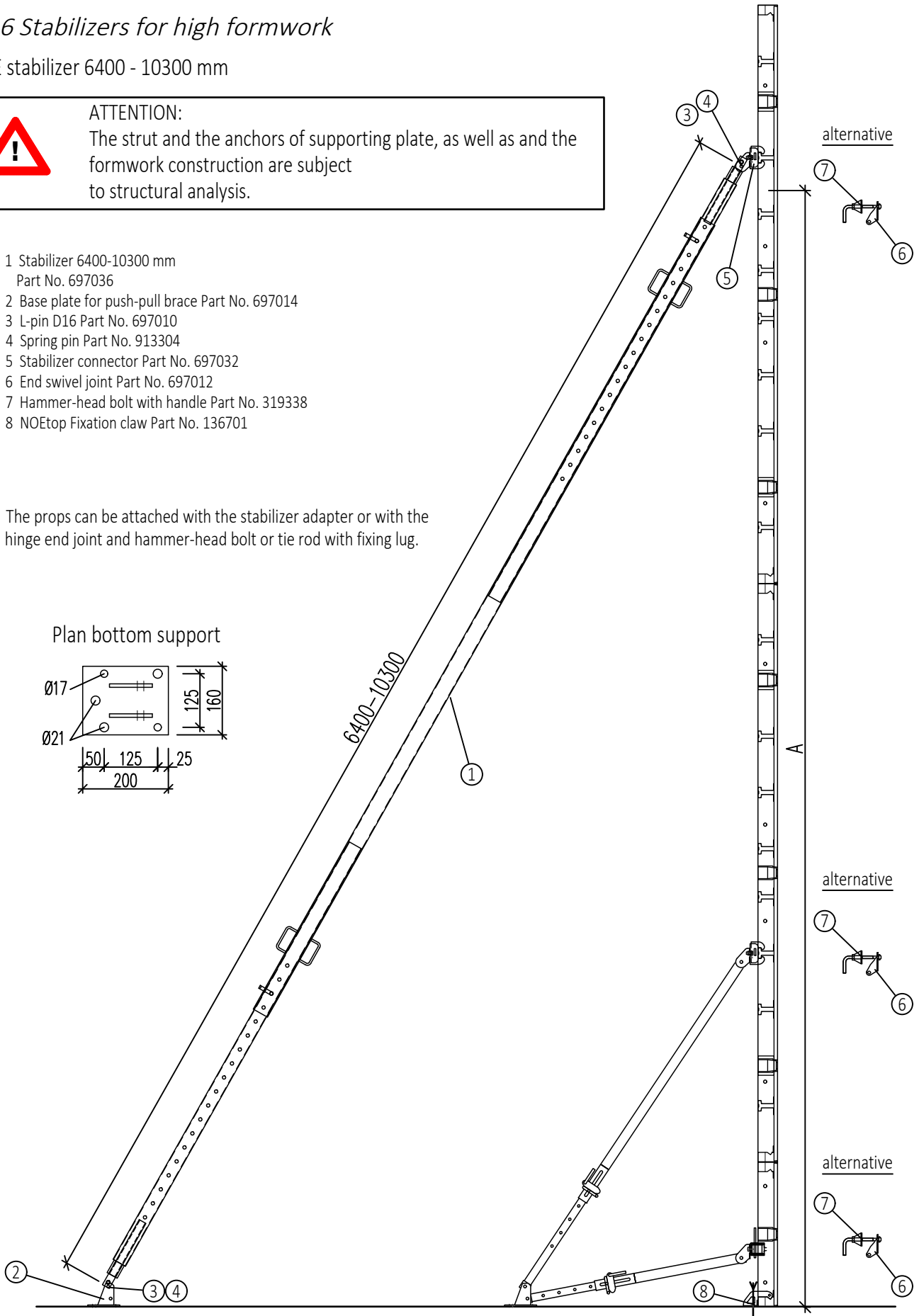
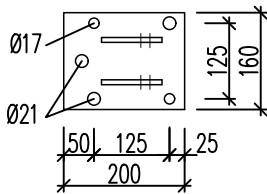

NOEtop4 Formwork

13. Individual parts of NOEtop4 formwork

13.1 NOEtop4 panels

13.1.1 Overview of formwork elements

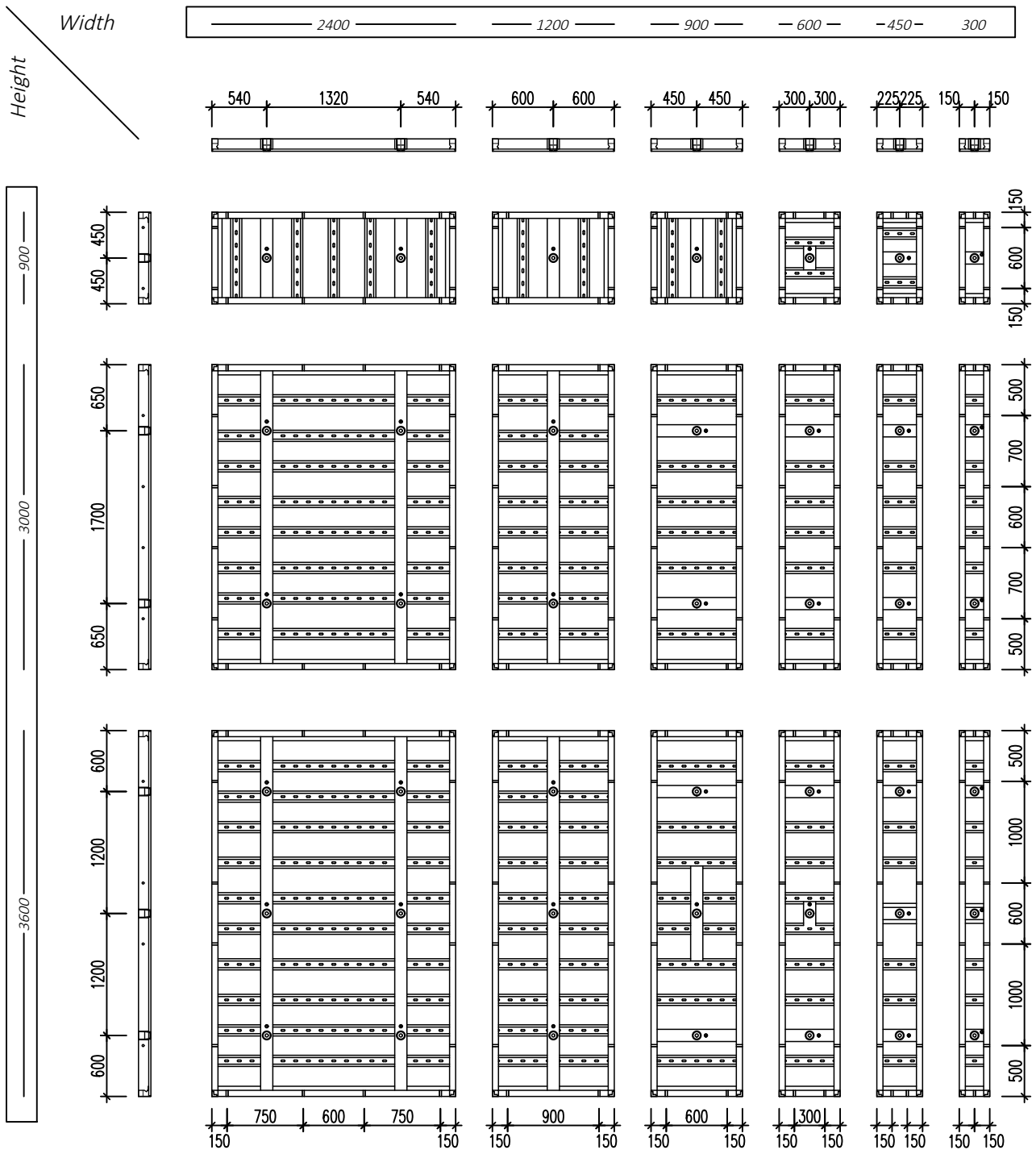



Width modules

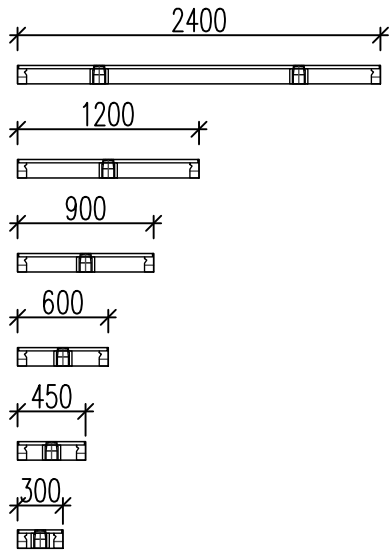

Panel elements
Height 3600 mm

Width mm	Height mm	Panel area m ²	Panel faced NOEform (timber)		Panel faced with NOEecopan (plastic)	
			Weight kg	Part No.	Weight kg	Part No.
2400	3600	8,64	598,90	165020	586,83	165120
1200		4,32	328,25	165022	322,34	165122
900		3,24	250,69	165024	246,43	165124
600		2,16	178,07	165026	175,36	165126
450		1,62	146,74	165028	144,84	165128
300		1,08	116,29	165030	115,24	165130

Panel elements
Height 3000 mm

Width mm	Height mm	Panel area m ²	Panel faced NOEform (timber)		Panel faced with NOEecopan (plastic)	
			Weight kg	Part No.	Weight kg	Part No.
2400	3000	7,20	499,87	165040	489,66	165140
1200		3,60	273,92	165042	268,98	165142
900		2,70	196,00	165044	192,45	165144
600		1,80	146,21	165046	143,97	165146
450		1,35	121,03	165048	119,44	165148
300		0,90	96,06	165050	95,13	165150

Height modules

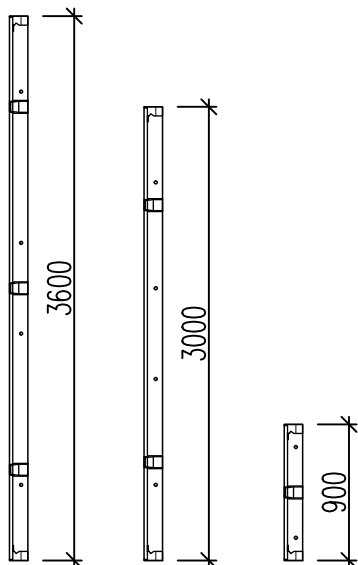

Panel elements
Height 900 mm

Width mm	Height mm	Panel area m ²	Panel faced NOEform (timber)		Panel faced with NOEecopan (plastic)	
			Weight kg	Part No.	Weight kg	Part No.
2400	900	2,16	169,86	165060	167,01	165160
1200		1,08	90,56	165062	89,21	165162
900		0,81	80,80	165064	79,79	165164
600		0,54	51,66	165066	51,00	165166
450		0,40	46,05	165068	45,62	165168
300		0,27	31,87	165070	31,66	165170

13.1.2 Elevations and sections

Element 3600 mm high
Width 2400-300 mm

Section

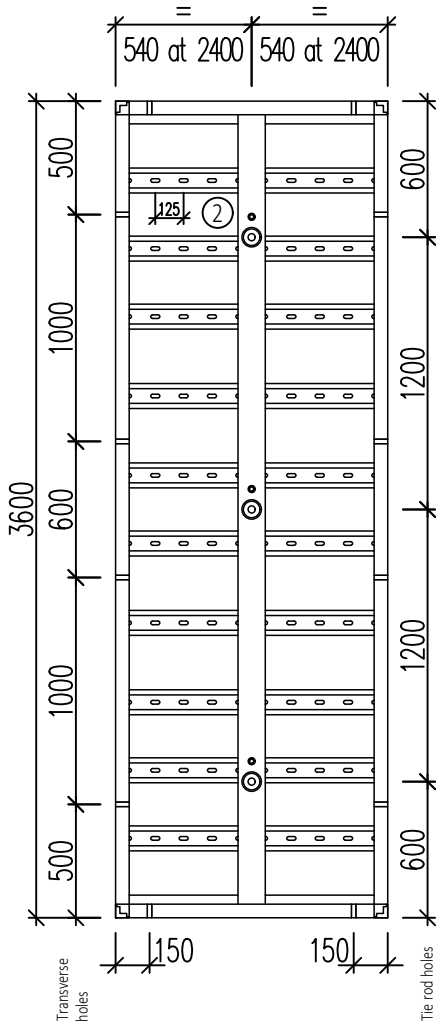

Element 3000 mm high
Width 2400-300 mm

Section

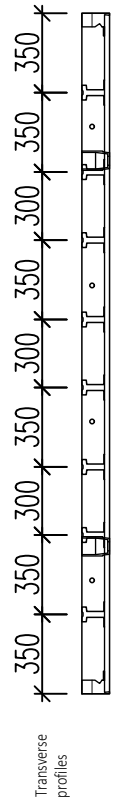
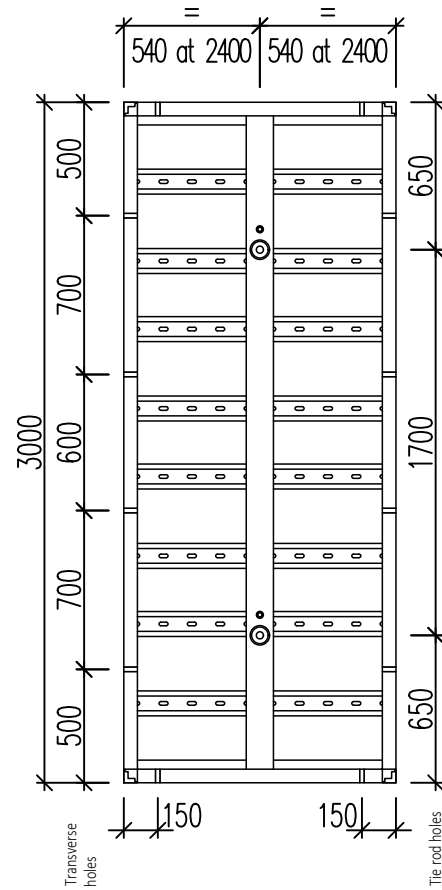
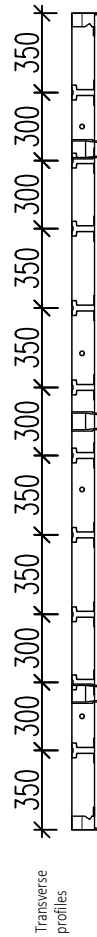

Element 900 mm high
Width 2400-300 mm

Section

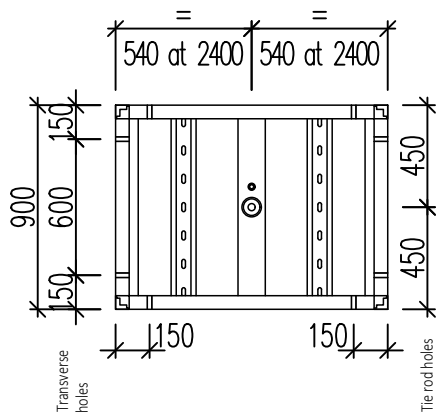

Profiles

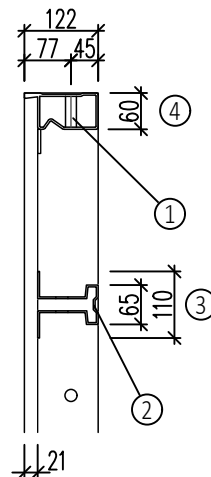

Detail tie rod hole/
bearing shell

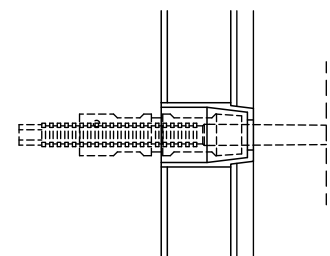

- 1 $\phi 19$
- 2 LL18/40
- 3 Hat profile
- 4 Edge profile



13.2 NOEtop4 internal corner IC, 300x300 mm

3600 mm high
3000 mm high
900 mm high

Section

The internal corner formwork can be folded in on itself by up to 4° for stripping.

Height mm	Panel area m ²	Panel faced NOEform (timber)		Panel faced with NOEcopan (plastic)	
		Weight kg	Part No.	Weight kg	Part No.
3600	2,16	134,60	165090	132,60	165190
3000	1,80	114,30	165092	112,70	165192
900	0,54	41,67	165094	41,27	165194

13.3 NOEtop4 external corner EC, 150x150 mm

13.4 NOEtop4 external corner angle ECA

3600 mm high
3000 mm high
900 mm high
3600 mm high
3000 mm high
900 mm high

Cross-section

Cross-section

Height mm	Panel area m ²	Panel faced NOEform (timber)		Panel faced with NOEcopan (plastic)	
		Weight kg	Part No.	Weight kg	Part No.
3600	1,08	156,86	165080	154,96	165180
3000	0,90	131,08	165082	129,48	165182
900	0,27	42,73	165084	42,23	165184

Height mm	Weight kg	Part No.
3600	23,34	850050
3000	19,90	850051
900	5,83	850052

NOEtop4 Formwork



13.5 NOEtop4 stripping corner 300x300 mm

Stripping clearance approx. 20 mm each side

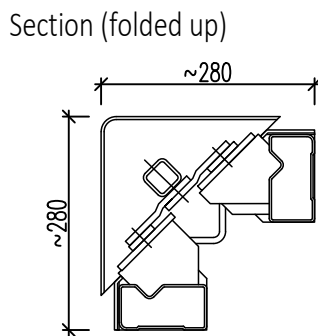
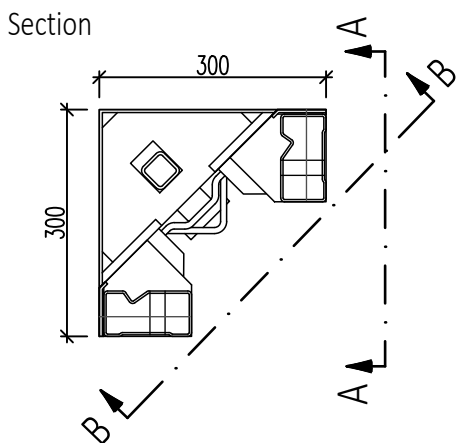
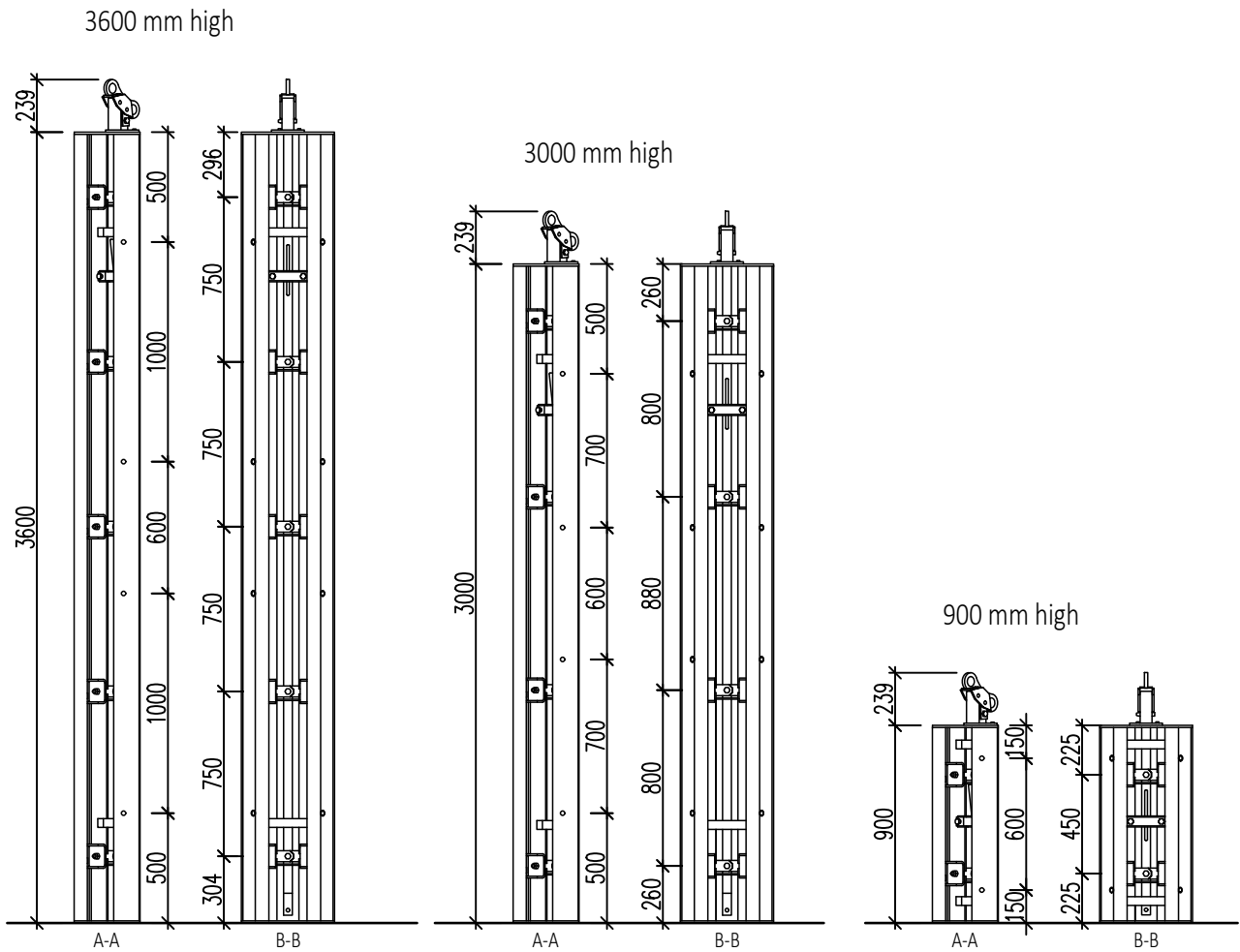

Lever f. NOEtop stripping corner

Part No. 398202
Weight 3.9 kg

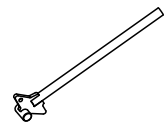

M18x160 bolt

Part No. 318900

M16x40 bolt

Part No. 313400

Height mm	Panel area m ²	Weight kg	Part No.
3600	2,16	227,98	137868
3000	1,80	191,95	137869
900	0,54	72,90	137870



13.6 Connections

NOE Toplock

For panel connections and longitudinal compensations up to 42 mm

Part No. 137976

Weight 3.7 kg

Perm. Tension force 15 kN

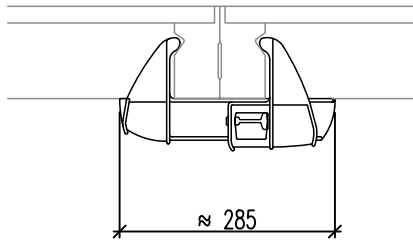

NOE Easylock

For panel connections

Part No. 137950

Weight 3.44 kg

Permissible tensile load 15 kN

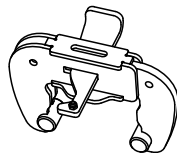
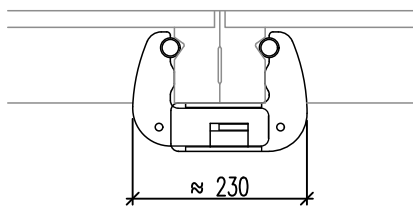

Extension clamp

For extending panels by 200 mm

Part No. 137850

Weight 3.2 kg

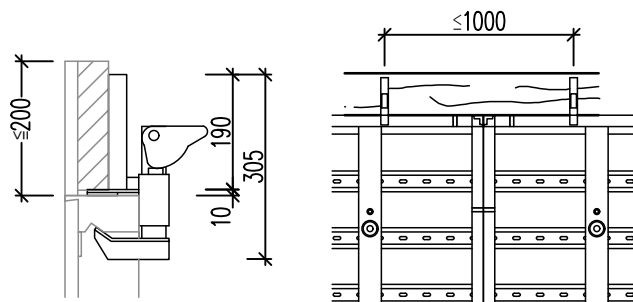

NOE Toplock X

For panel connections and longitudinal compensations up to 100 mm

Part No. 137960

Weight 4.3 kg

Perm. Tension force 20 kN

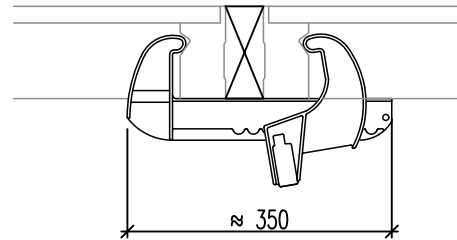

For panel connections and longitudinal compensations up to 100 mm can also be used Toplock H, part no. 137970, instead of Toplock X.

Alignment clamp

For extensions of end-on and side-on panels

Part No. 135309

Weight 19.9 kg

Elevation A : Extensions of end-on panels

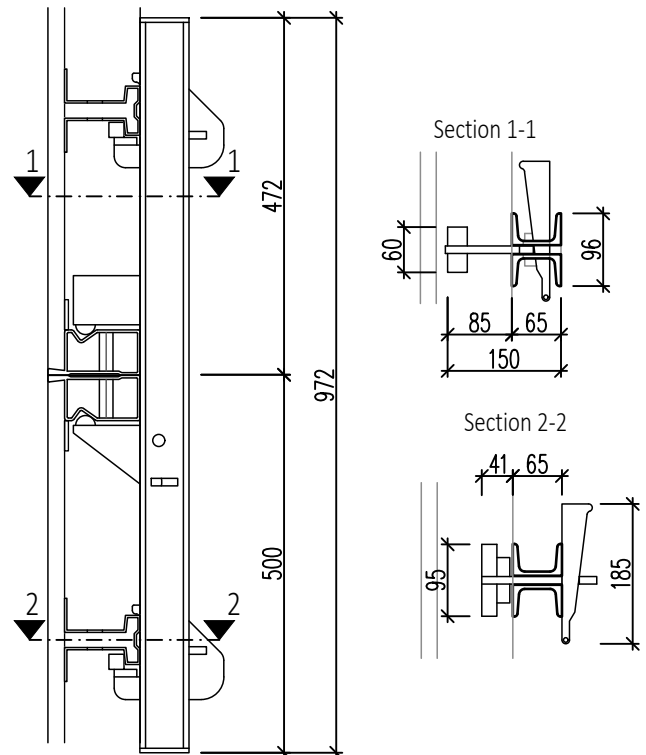

NOEtop4 Formwork

13.7 Tie rod fittings

NOEtop4 - one-sided ties (permissible tensile force in acc. with DIN 18216: 150 kN)

NOEtop4 - tie rod DW20

For wall thicknesses of 15 - 30 cm

Part No. 850008

Weight 2.58 kg

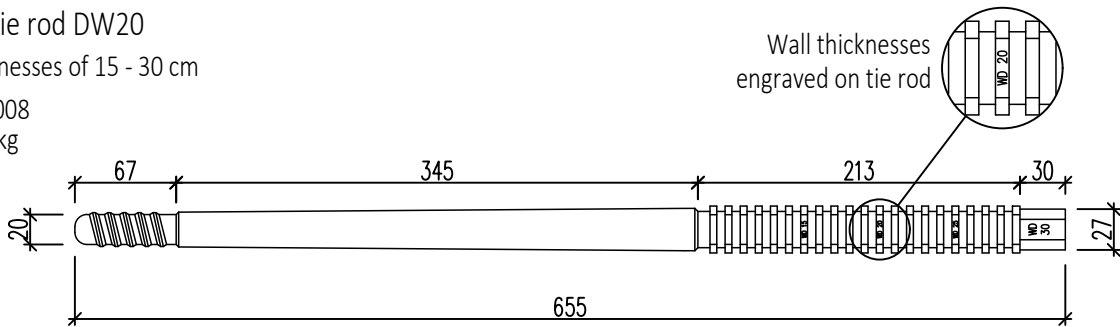

NOEtop4 - tie rod DW20

For wall thicknesses of 25 - 40 cm

Part No. 850009

Weight 2.99 kg

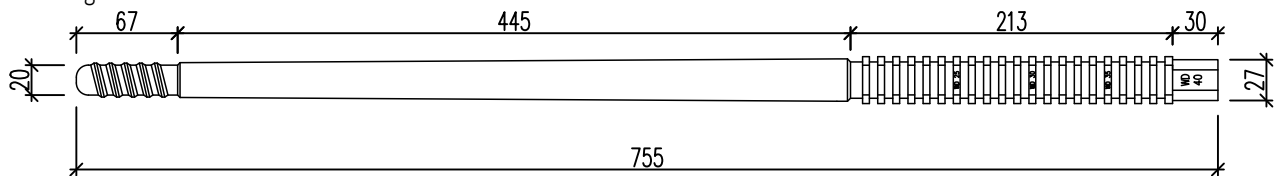

NOEtop4 - adjuster nut

For second-face formwork

Part No. 850006

Weight 1.8 kg

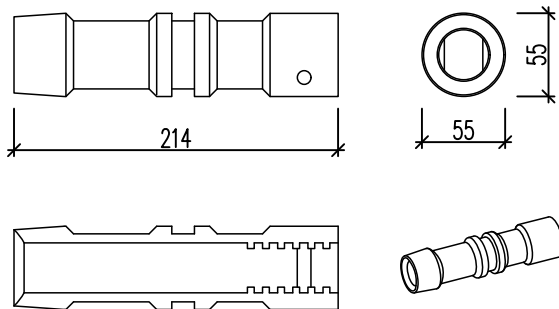

NOEtop4 - fixed bearing

For first-face formwork

Part No. 850007

Weight 0.9 kg

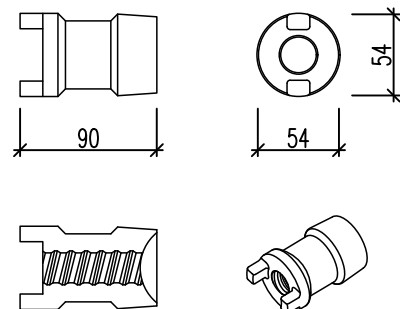

NOEtop4 - adjuster nut-locking clip

For second-face formwork

Part No. 850013

Weight 0.075 kg

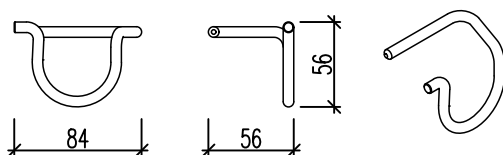

NOEtop4 - fixed bearing-securing pin

For first-face formwork

Part No. 850012

Weight 0.13 kg

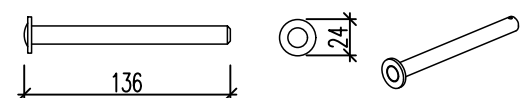

Secure with:
1x spring pin 3 mm, Part No. 913303

NOEtop4 Formwork



NOEtop4 - distance preserver

Part No. 850011
Weight 0.7 kg

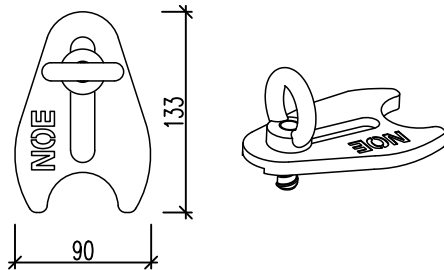

NOEtop4 - sealing pin

Part No. 928012
Weight 0.59 kg

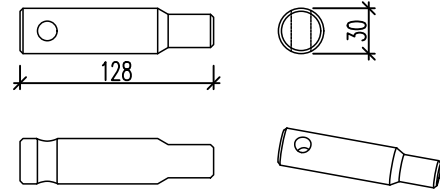

Sicherung mit:
1x Sicherungsbolzen, Teil-Nr. 850012
1x Federstecker 3 mm, Teil-Nr. 913303

NOEtop4 - Spannstabhalter

Teil-Nr. 850015
Gewicht 0,53 kg

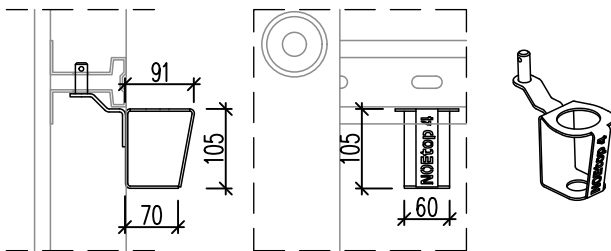

Sicherung mit:
1x Klappstecker, Teil-Nr. 913320

Klappstecker 4,5 mm

Teil-Nr. 913320
Gewicht 0,01 kg

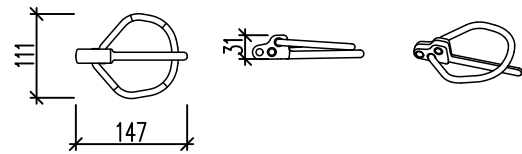

zur Sicherung des
NOEtop4 - Spannstabhalters

NOEtop4 - Montageschlüssel

Teil-Nr. 390360
Gewicht 3,00 kg

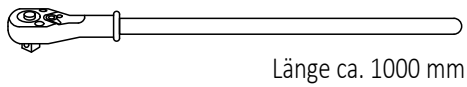

Stecknuss SW 24-3/4
Teil-Nr. 390361



NOEtop4 - tie rod hole seal

Part No. 850005

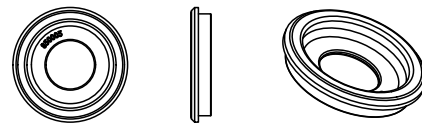

NOEtop tie rod \varnothing 20 mm (Permissible tension force in acc. with DIN 18216: 160 kN)

Tying nut

Part No. 680009
Weight 0.4 kg

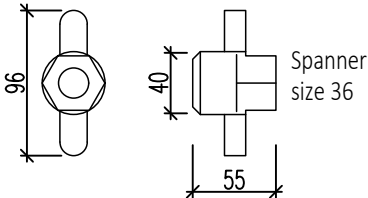

Waling plate

Part No. 691509
Weight 0.7 kg

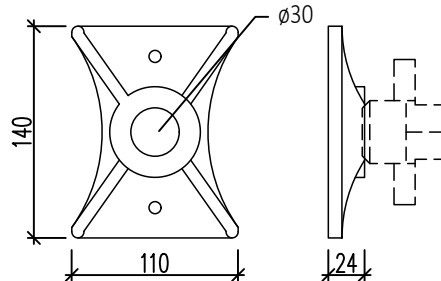

Wing nut with swivel plate

Part No. 691600
Weight 1.0 kg

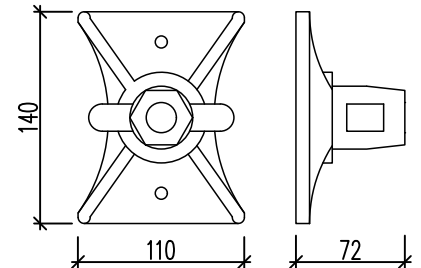

Tie rod \varnothing 20

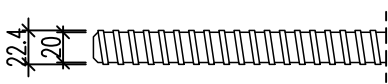

Length 950 mm Part No. 670959 Weight 2.4 kg

Length 1250 mm Part No. 671259 Weight 3.2 kg

13.8 Bracing and hammer-head bolts

Compensation channel

For filler piece up to 250 mm

Part No. 135109
Weight 9.6 kg

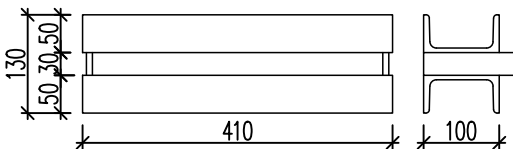

Extension channel

For stopend forms and aligning panels

Part No. 135208
Weight 15.9 kg

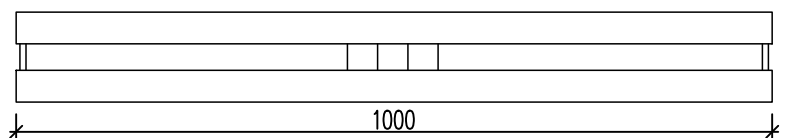
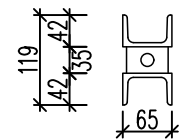

Alignment channel

For stopend forms and aligning panels

Part No. 135210
Weight 21.5 kg

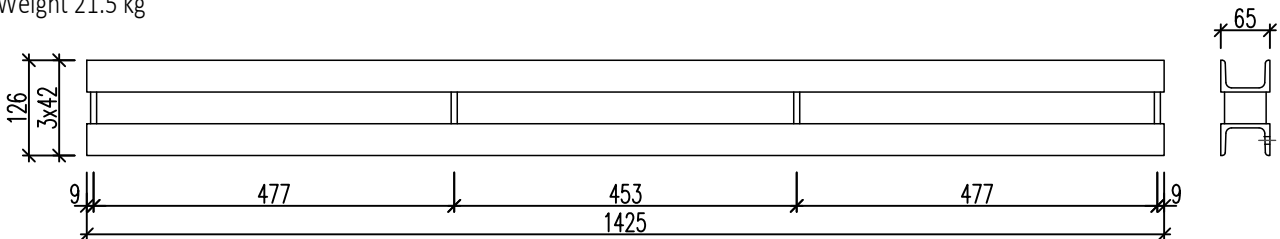

NOEtop4 - alignment channel

For stopend forms and aligning panels

Part No. 850039
Weight 24.5 kg

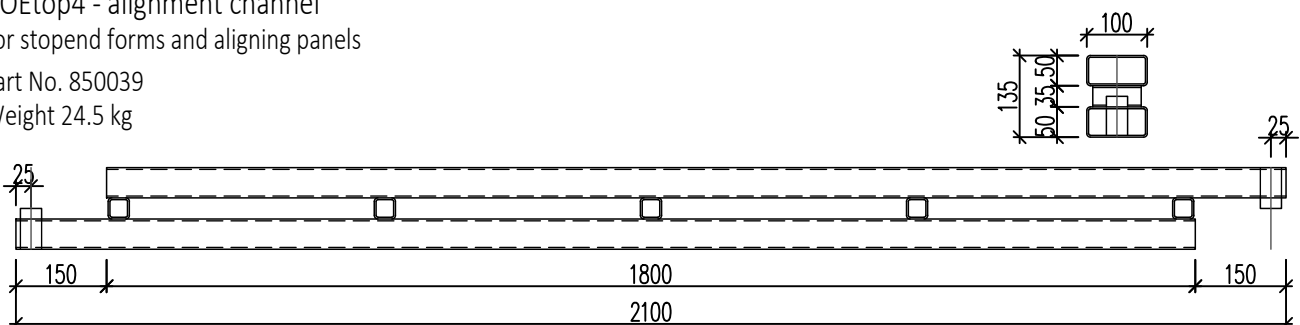



Hammer-head bolt with handle and integral nut

Part No. 319338
 KL ≤ 125 mm
 Weight 1.1 kg

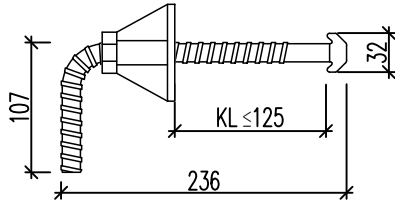

Part No. 319339
 KL ≤ 205 mm
 Weight 1.2 kg

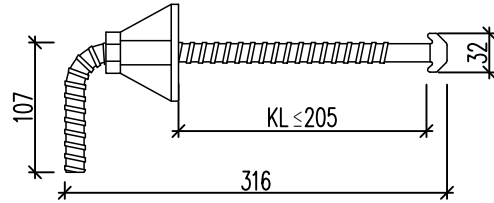

Hammerhead bolt with handle

Part No. 319343
 Head length (KL) ≤ 230 mm
 Weight 1,2 kg

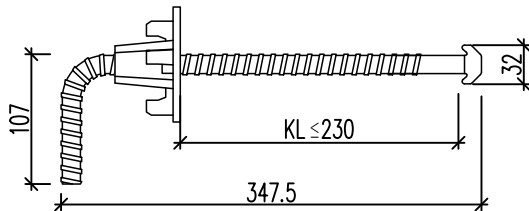

NOEtop4 - tie rod with fixing lug

Part No. 850014
 Weight 0.66 kg

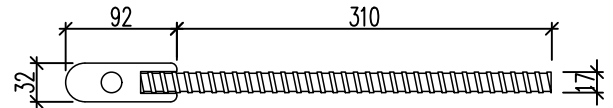

L-pin (Part No. 697010) +
 spring pin (Part No. 913304)
 required

Connection screw

Part No. 135019
 Weight 0.6 kg

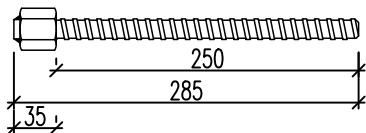

Thread 15 mm with hexagonal nut 30 mm
 e.g. for EC panels and corner hinges

Stop-end holder 15 kN

Part No. 164032
 Weight 0.7 kg

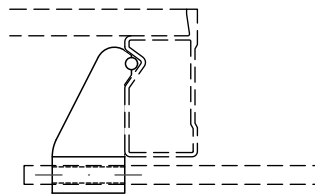

Stop-end holder 25 kN

Part No. 164036
 Weight 2,1 kg

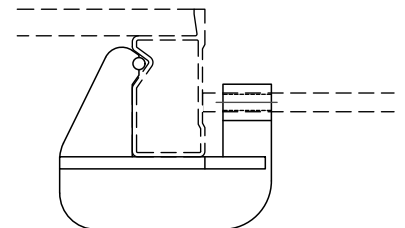

Hexagonal bolt M18x160

Part No. 318900
 Weight 0.5 kg
 For bolting to edge profiles

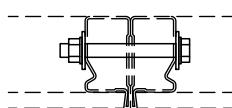

Hexagonal bolt M18x100

Part No. 318801
 Weight 0.36 kg

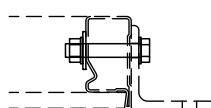

L-pin D16

Part no. 697010
 Weight 0,34 kg

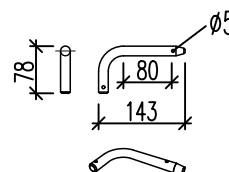

Spring pin 4 mm

Part no. 913304
 Weight 0,02 kg



For securing the L-pin

13.9 Transport equipment

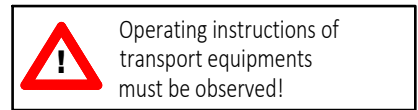

Lifting pin

Permissible load Z = 0.5 t or 5 kN
Part No. 136808
Weight 0.7 kg

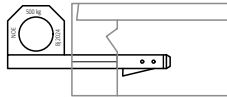

Crane hook

Part No. 135905
Weight 6.8 kg

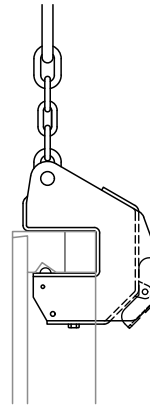

Permissible load see operating instructions or 12.1.4

Use permitted only in accordance with the operating instructions !

13.10 Foundation tying equipment

Tying claw

Part No. 137500
Weight 1.7 kg

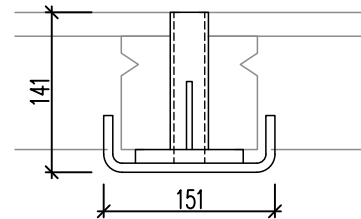
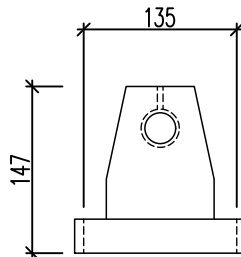
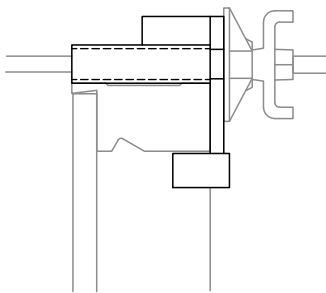

For tying over the top of a panel or outside the tie rod hole, e.g. for foundations, at window openings, etc.

NOEtop Foundation clamp

Part No. 137297
Weight 1.5 kg

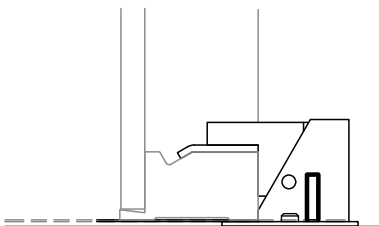

For strip-steel stressing devices for foundation panels.

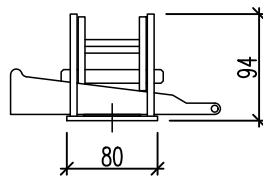

Strip-steel stressing device

Part No. 108031
Weight 24 kg
Cut to length at a hole centre!

Holes 50 mm c/c

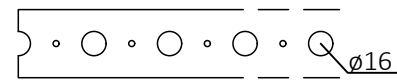

Supplied in 50 m rolls.
Permissible tension force 12 kN.

Fixation claw

Part No. 136701
Weight 1.2 kg

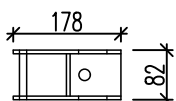
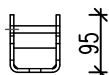
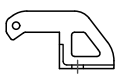

For uplift safety device of formwork

13.11 Scaffolds and accessories

Walkway bracket

Part No. 552204
Weight 12,4 kg

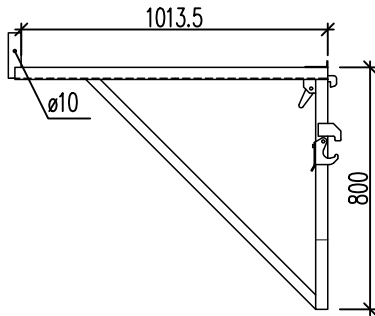

Handrail tube

Part No. 111400
Weight 4,0 kg

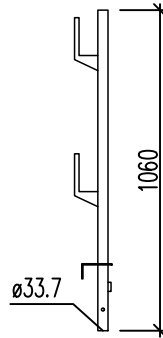

Handrail tube

Part No. 111403
Weight 5,0 kg

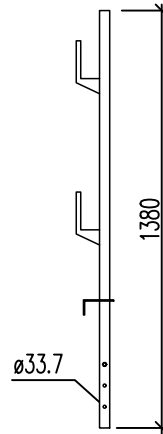

NOEtop clamp support handrail tube

Part No. 552214
Weight 3.1 kg

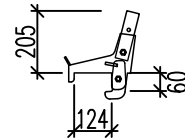

Plug 9 mm
for use with handrail tube
Part No. 890834



13.12 Raking props

Prop push-pull 1000-1510 mm

Part no. 697026
Weight 9.4 kg
perm. load 29.7 kN

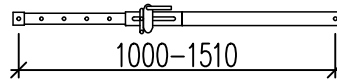

Prop push-pull 2100 - 3650 mm

Part no. 697027
Weight 19.1 kg
perm. load 29.7 - 12.8 kN

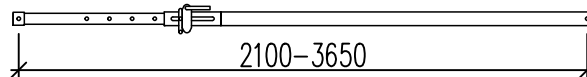

Prop push-pull 2800-5000 mm

Part no. 697028
Weight 25.7 kg
perm. load 29.7 - 6.8 kN

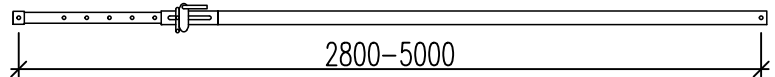

Prop push-pull 5000-7500 mm

Part no. 697133
Weight 60.1 kg
perm. load 20.0 - 11.1 kN

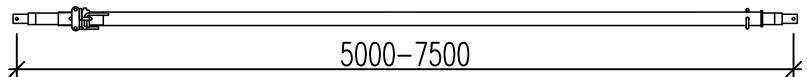



Base plate for push-pull brace

Part no. 697014
Weight 3,8 kg

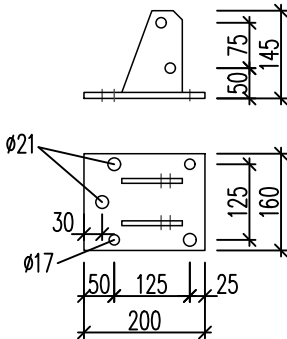

NOEtop stabilizer connector

Part no. 697032
Weight 3,0 kg

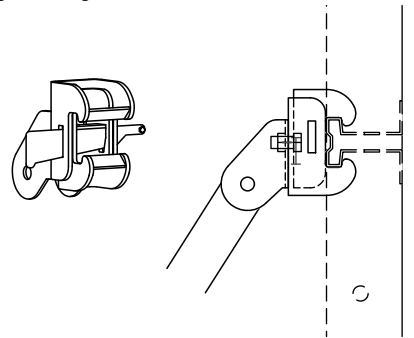

L-pin D16

Part no. 697010
Weight 0,34 kg

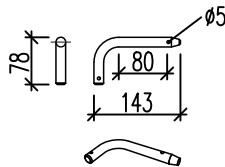

Spring pin 4 mm

Part no. 913304 for securing the L-pin
Weight 0,02 kg



13.13 Formwork supports

NOEtop formwork support

Adjusting range 75 mm

Part No. 164700
Weight 9,8 kg

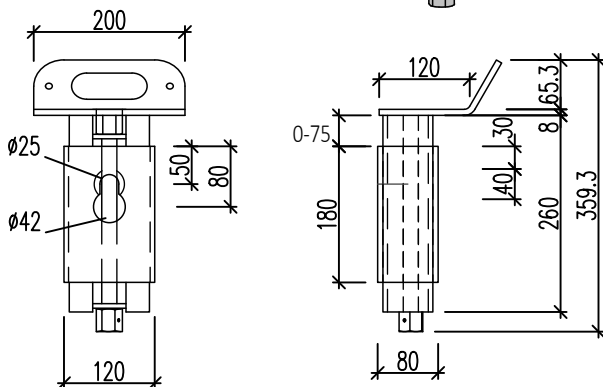
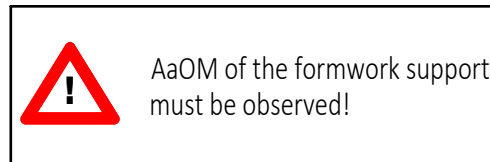
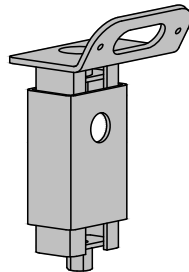

NOEtop bolt

DW 15 x 105
Part No. 164704
Weight 0,3 kg

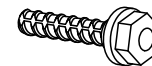

NOE washer form A17 DIN 125
d=3 mm, Install 2 pieces, if the anchor cap with nailing plate was installed

Part No. 380026
Weight 3,68 kg
Packaging unit: 250 pieces

NOEtop4 Formwork



NOE anchor cap

Pack: 50 pieces
 Part No. 694901
 Weight 3,35 kg

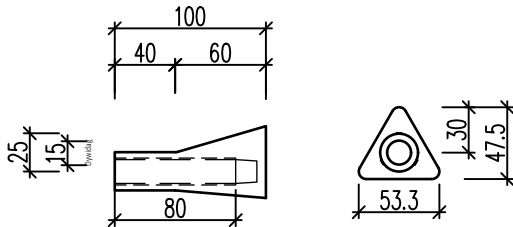

NOE plug

Pack: 50 pieces
 Part No. 694904
 Weight 0,1 kg

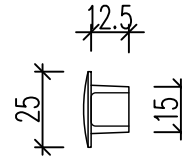

NOE nailing plate

Pack: 50 pieces
 Part No. 694903
 Weight 0,4 kg

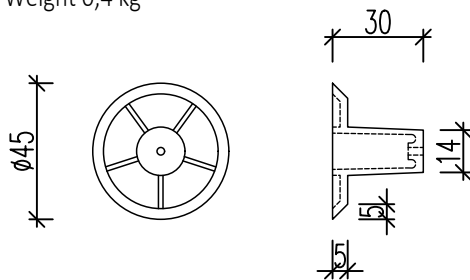

NOE nailing plug

Pack: 50 pieces
 Part No. 694902
 Weight 0,2 kg

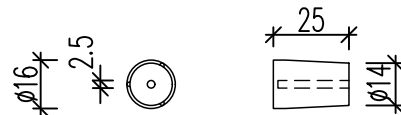

NOE Spanner for nailing plate

Part No. 466712
 Weight 0,4kg

NOE-Schaltechnik**Georg Meyer-Keller GmbH + Co. KG**

Kuntzestr. 72
73079 Süssen
Tel. +49 7162 13-1
info@noe.de
www.noe.eu

Belgium

NOE-Bekistingtechniek N.V.
Leuvensesteenweg 613
1930 Zaventem
info@noe.be
www.noe.eu

France

NOE-France
Depot Central
7 rue Maurice Bellonte
02100 Saint Quentin
info@noefrance.fr
www.noe.eu

Netherlands

NOE-Bekistingtechniek b.v
Postbus 25
4240 CA ARKEL
info@noe.nl
www.noe.eu

Austria

NOE-Schaltechnik GmbH & Co KG
Trientlgasse 25
6020 Innsbruck
noe@noe-schaltechnik.at
www.noe.eu

Poland

NOE-PL Sp. z.o.o.
ul. Jeziorki 84
02-863 Warszawa
noe@noe.pl
www.noe.pl

Switzerland

NOE-Schaltechnik GmbH
Nordringstrasse 28
4702 Oensingen
info@noe.ch
www.noe.eu